

ASSEMBLY-DISASSEMBLY- FMS-NMS 185

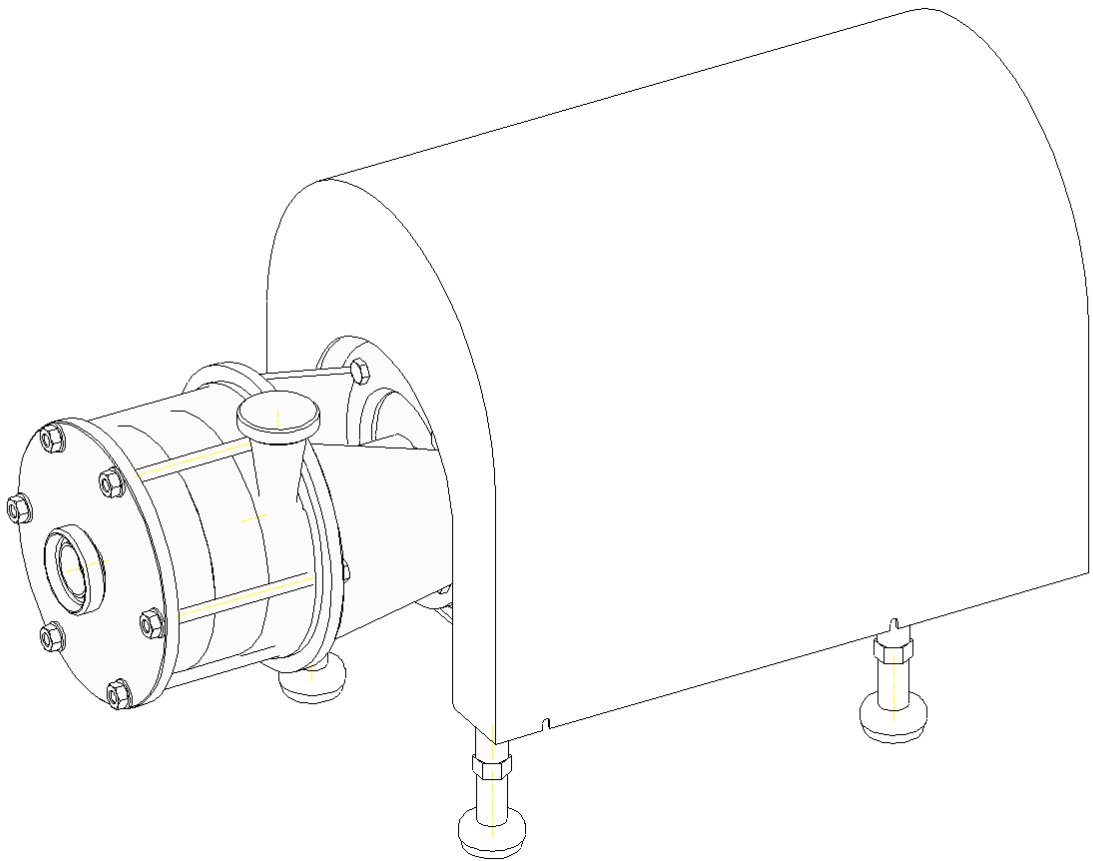

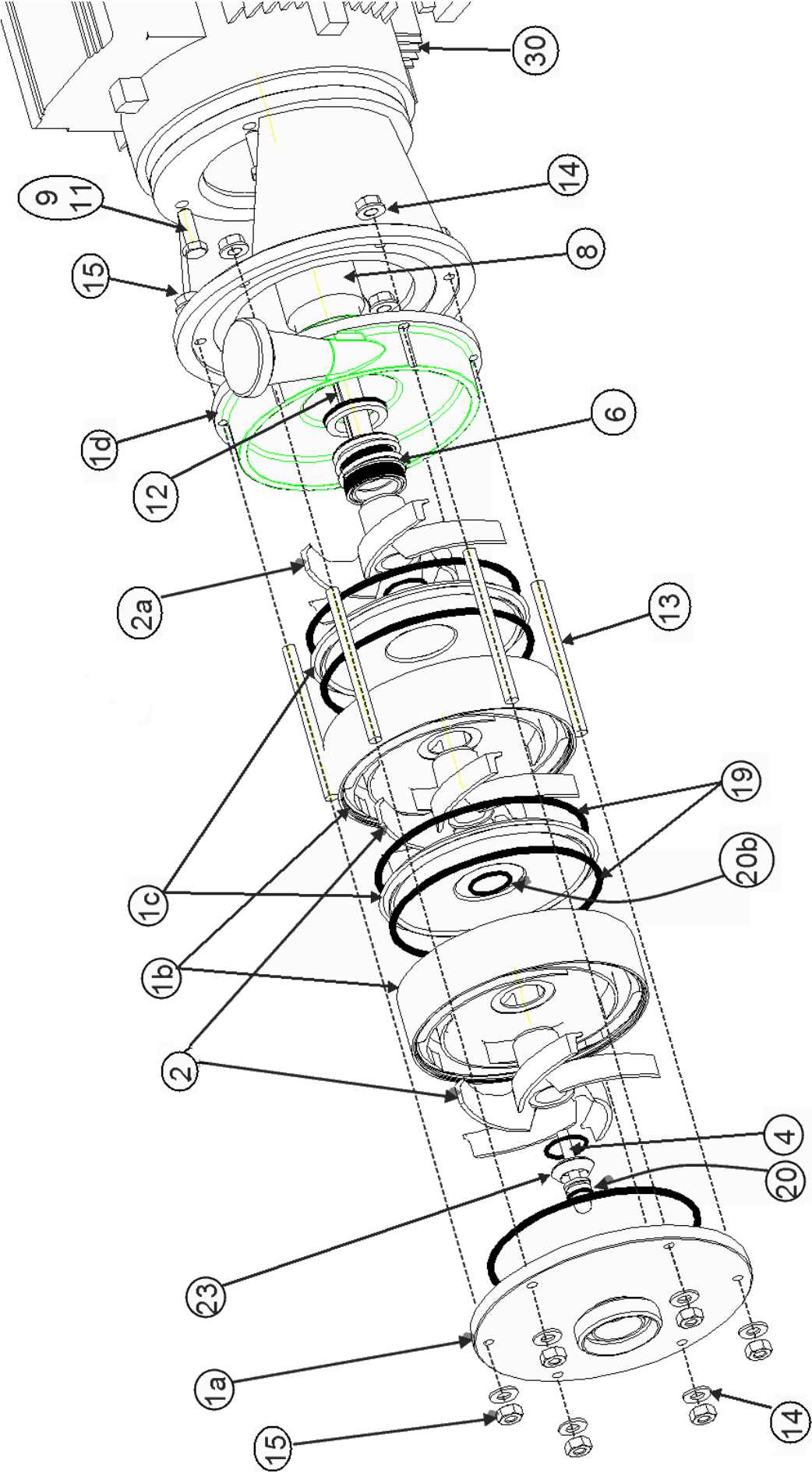

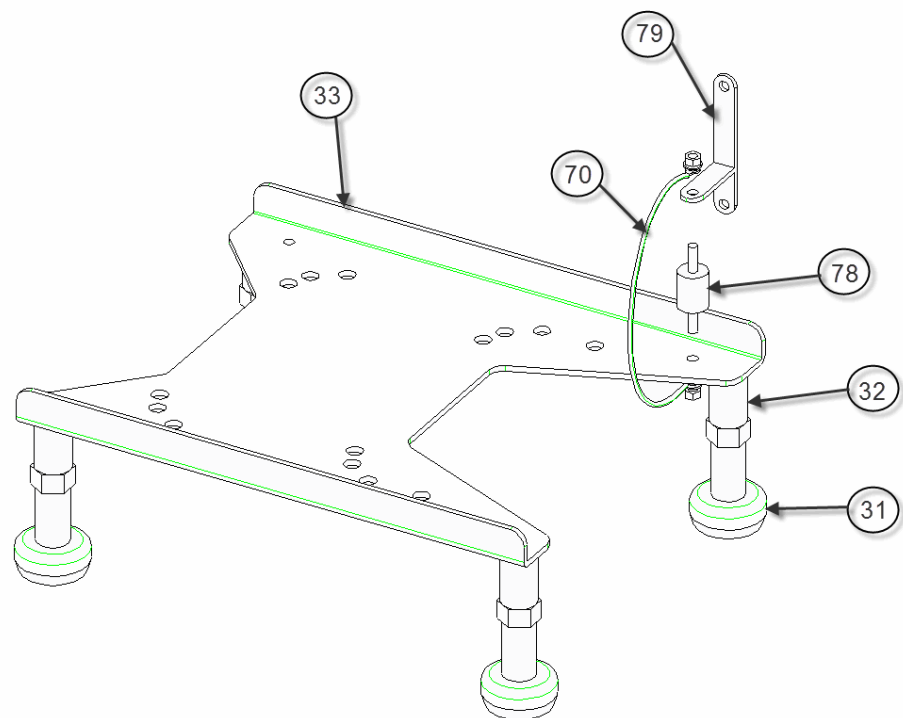
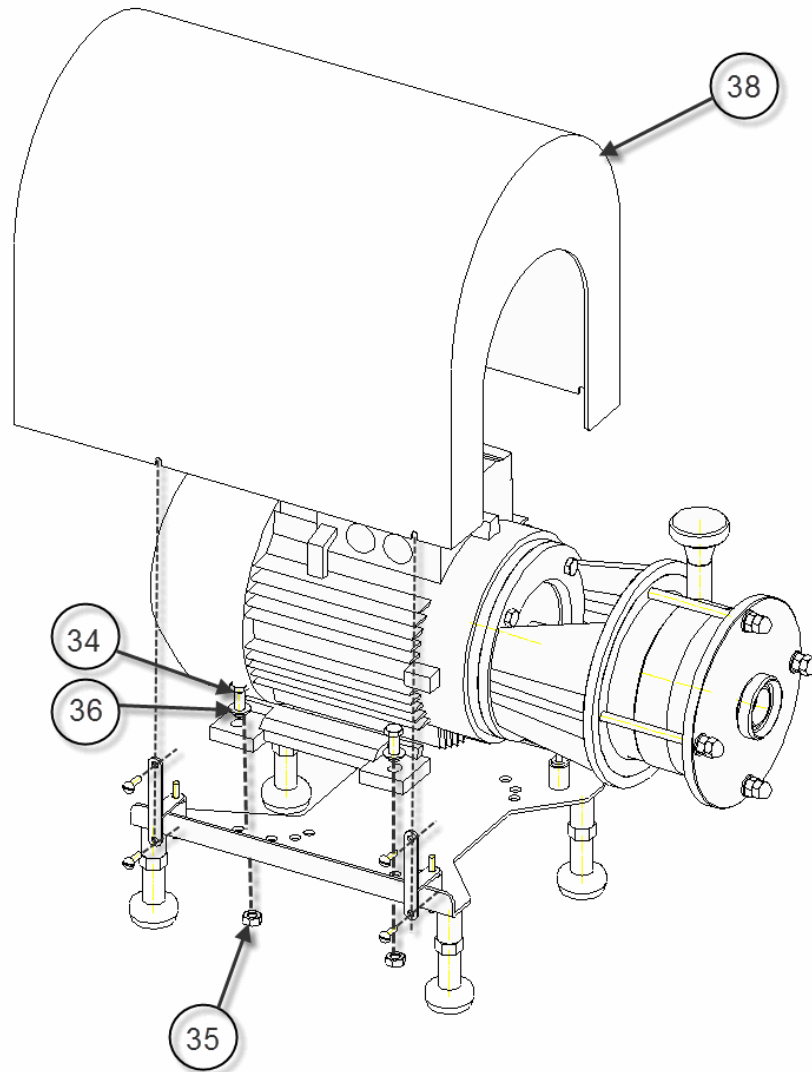

BOM

Pos	Part name
1a	Inlaattrap/Stage d'aspiration/Inlet stage/Saugstufe
1b	Diffusortrap/Diffuseur/Diffusor stage/Diffusorstufe
1c	Tussenschijf/Disque/Disc stag/Scheibe
1d	Uitlaattrap/Stage de refoulement/Outlet stage/Druckstufe
2	Waaier/Roue/Impeller/Laufrad
2a	Waaier uitlaattrap/Roue stage de refoulement/Outlet Stage Impeller/Druckstufiges Laufrad
3	Tussenstuk/Manchette de raccordement/Bracket/Laterne
4	Impellervijls/Vis de roue/Impeller screw/Laufradschraube
5	Pompachterplaat/Fond de pompe/Back plate/Gehäuseplatte
6	Mechanische asafdichting/Garniture mécanique/Mechanical seal/Gleitringdichtung
7	2e mechanische asafdichting/2ième Garniture méc./2nd Mechan. Seal/2e Gleitringdichtung
8	Pompas/Arbre de pompe/Pump shaft/Pumpenwelle
9	Bevestigingsvijls/Vis de fixation/Fixation screw/Sechskant-schraube
10	Moer/Ecrou/Nut/Mutter
11	Rondsel/Rondelle/Washer/Federscheibe
12	Spie/Clavette/key/Passfeder
13	Draadstang/Goujon/Threaded stud/Stiftschraube
14	Rondsel/Rondelle/Washer/Federscheibe
15	Dopmoer/Ecrou /nut/mutter
19	Pomphuisdichting/Joint de corps de pompe/Gasket for pump casing/Dichtring für Pumpengehäuse
20	impellervijls O-ring/joint de vis de roue/impeller screw o-ring/Dichtring für Laufradschraube
20b	impeller O-ring/joint de roue/impeller o-ring/Dichtring für Laufrad
23	Impeller screw washer/Rondelle de vis de roue/impellervijlsrondsel/Unterlegscheibe für Laufradschraube
29	Drukvijs/Vis de pression/Setscrew/Gewindestift
30	Motor/Moteur/Motor/Motor
31	Regelbaar voetje/Pied réglable/Level setting screw/Höhenverstellbarer Fuß
32	Moer/Ecrou/Nut/Mutter
33	Motorstoel / Support moteur/Baseplate/Montagekonsole
34	Vijls/Vis/Screw/Schraube
35	Moer/Ecrou/Nut/Mutter
36	Rondsel/Rondelle/Washer/Federscheibe
37	Vijls/Vis/Screw/Schraube
38	Beschermingskap/Capotage/Motor shroud/Haube
70	Aardingskabel voor kap/Câble de mise à la terre pour support/Earth connection cable for shroud/Erdungskabel für Haube
78	Trildemper voor kap/Amortisseur pour capotage/Shock absorber for shroud/Stoßdämpfer
79	Steuntje voor kap/Support pour capotage/Support for shroud/Stütze für Haube

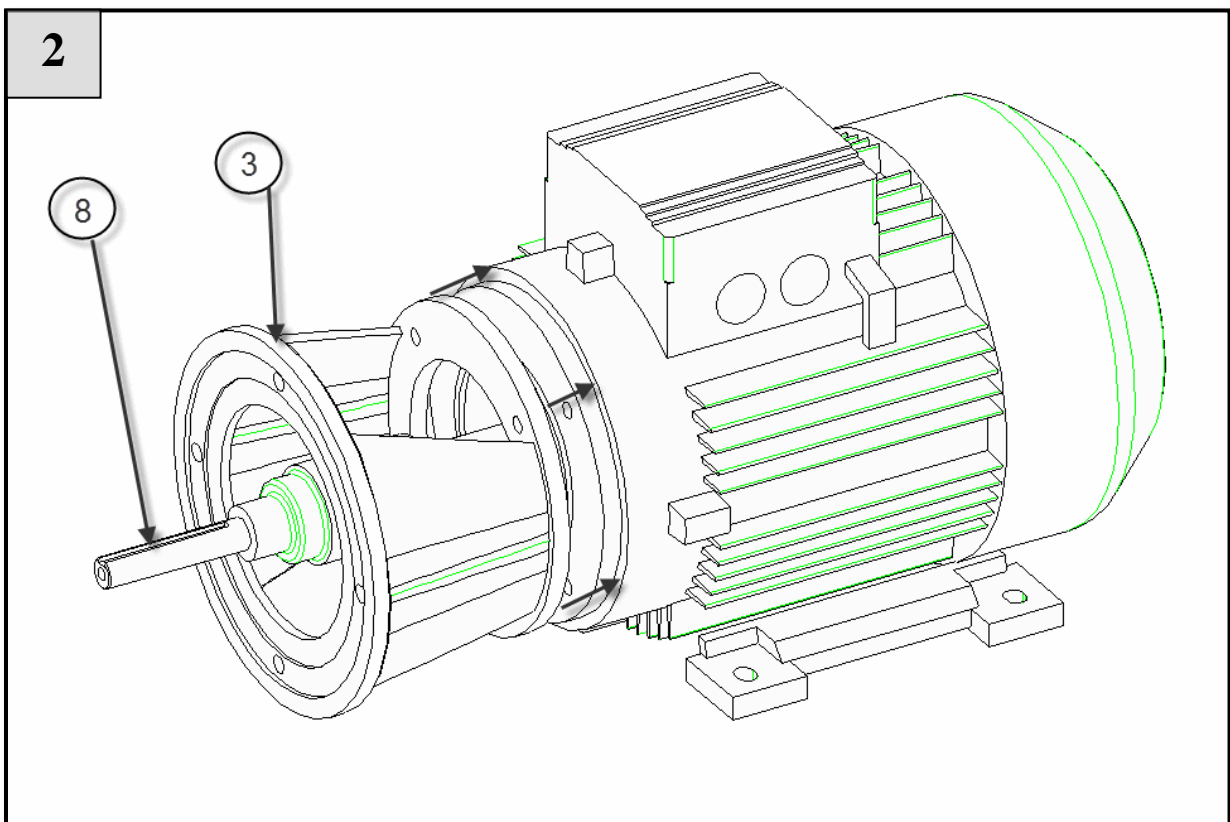
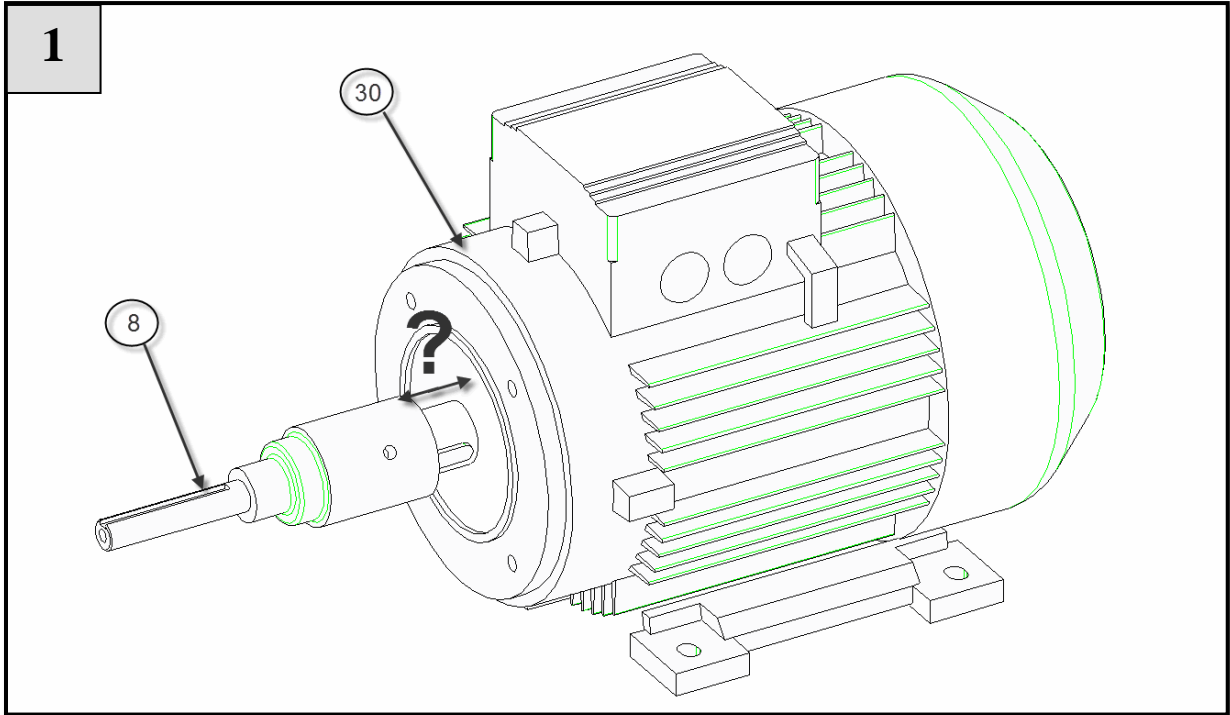

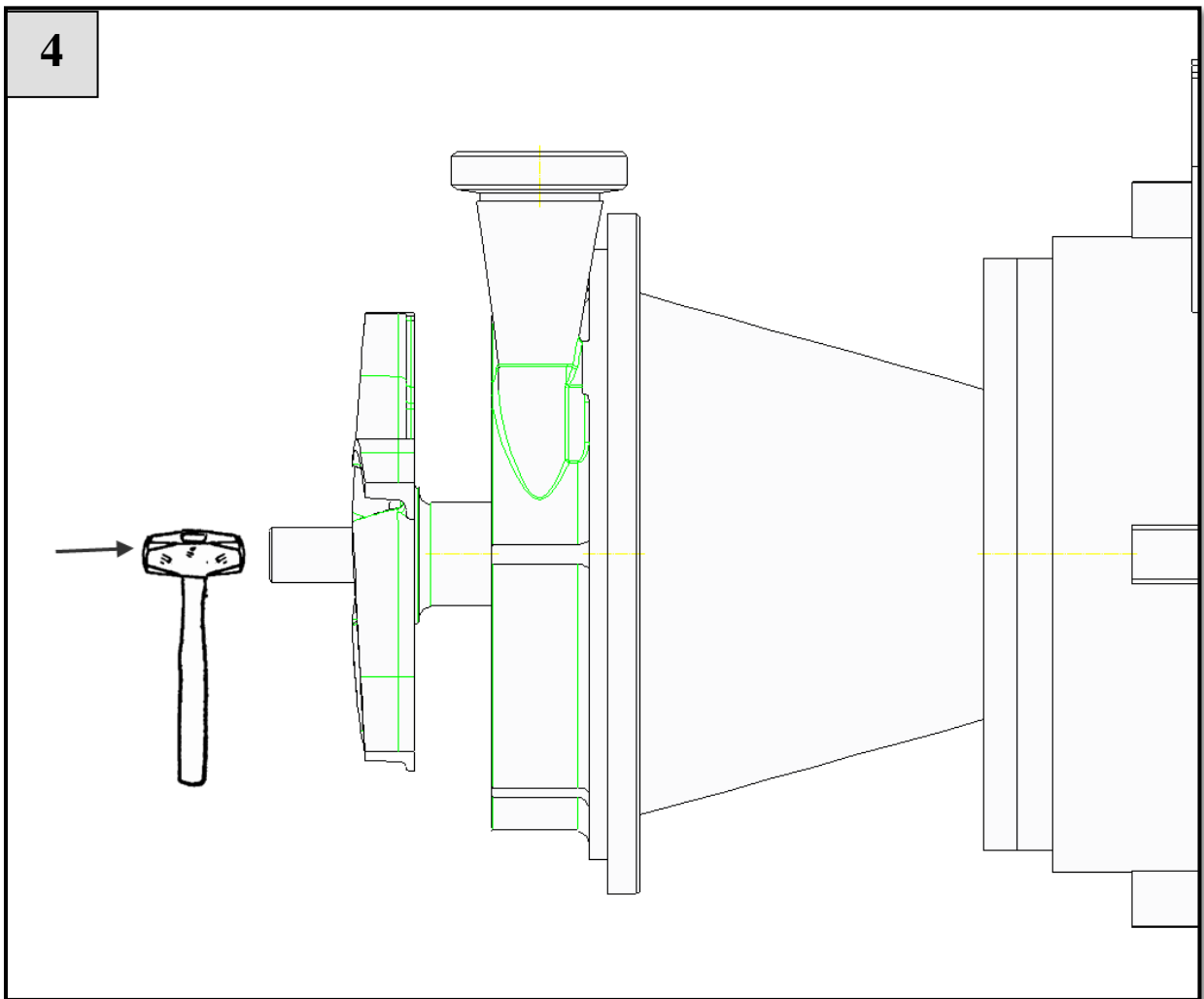
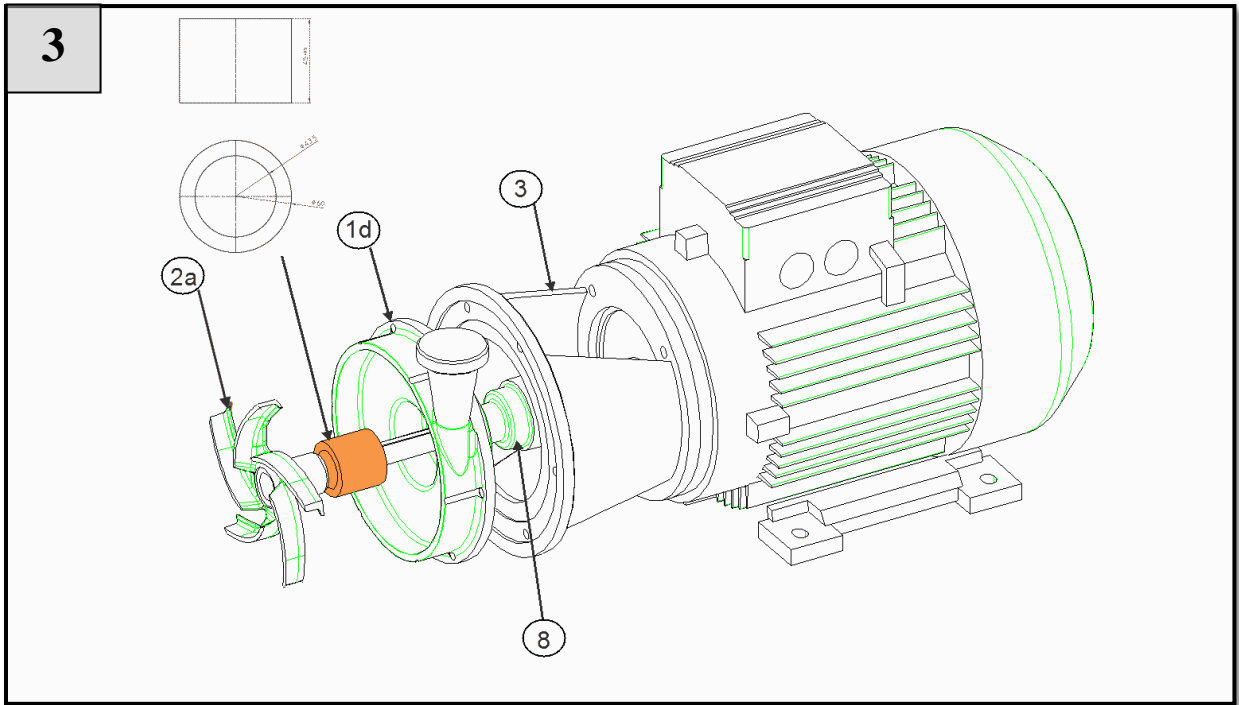

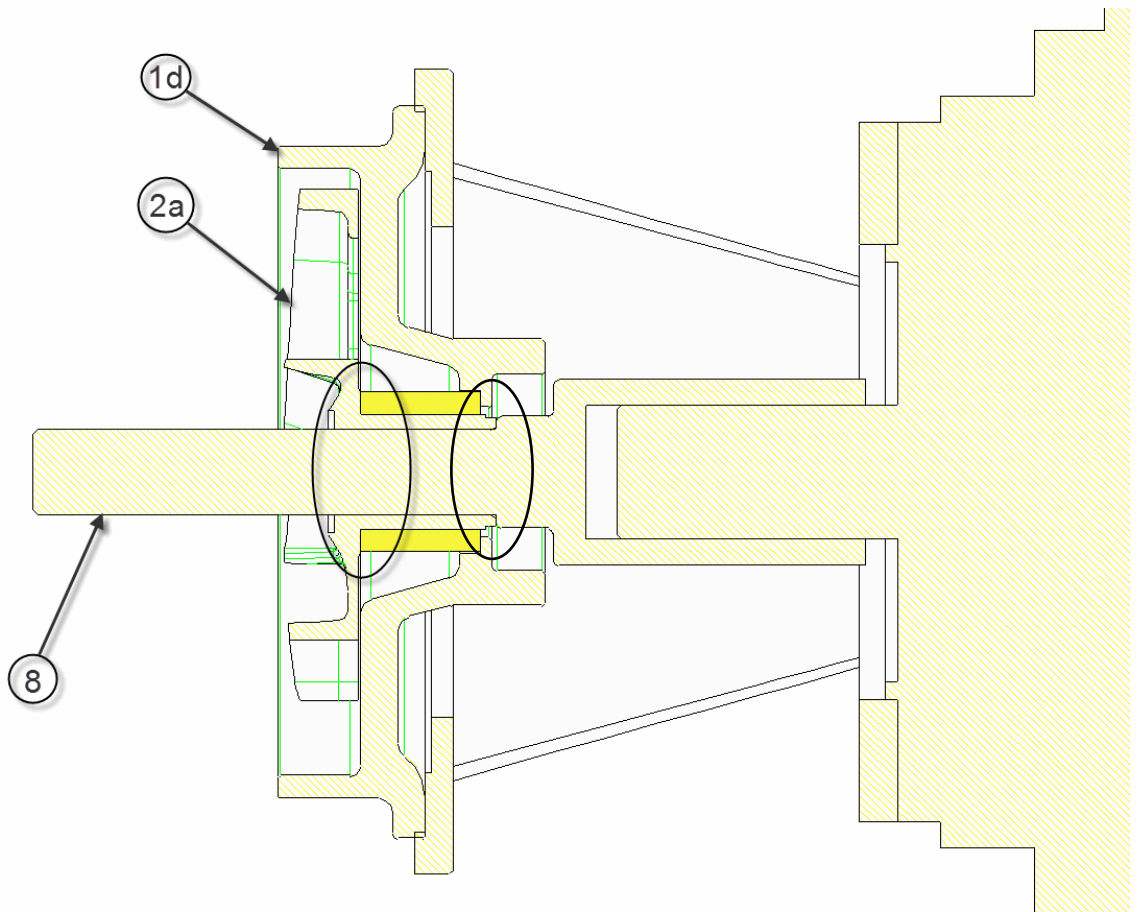
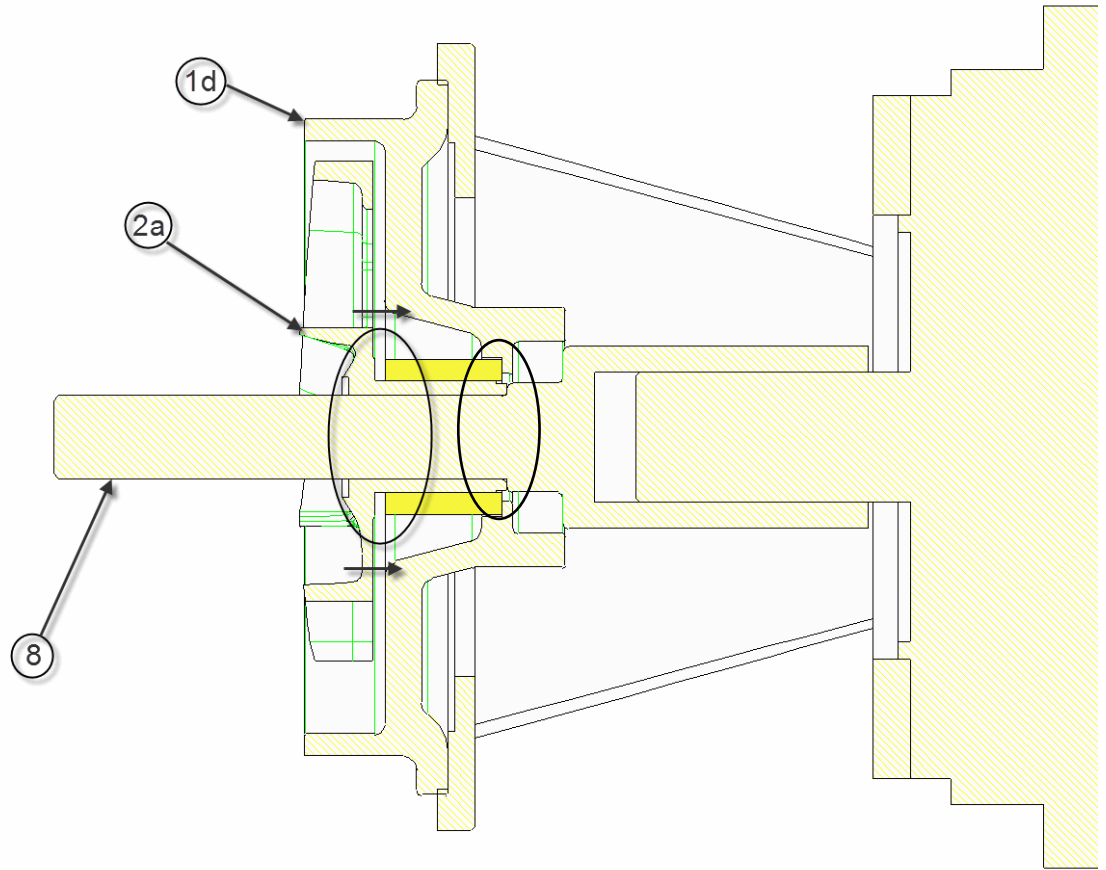

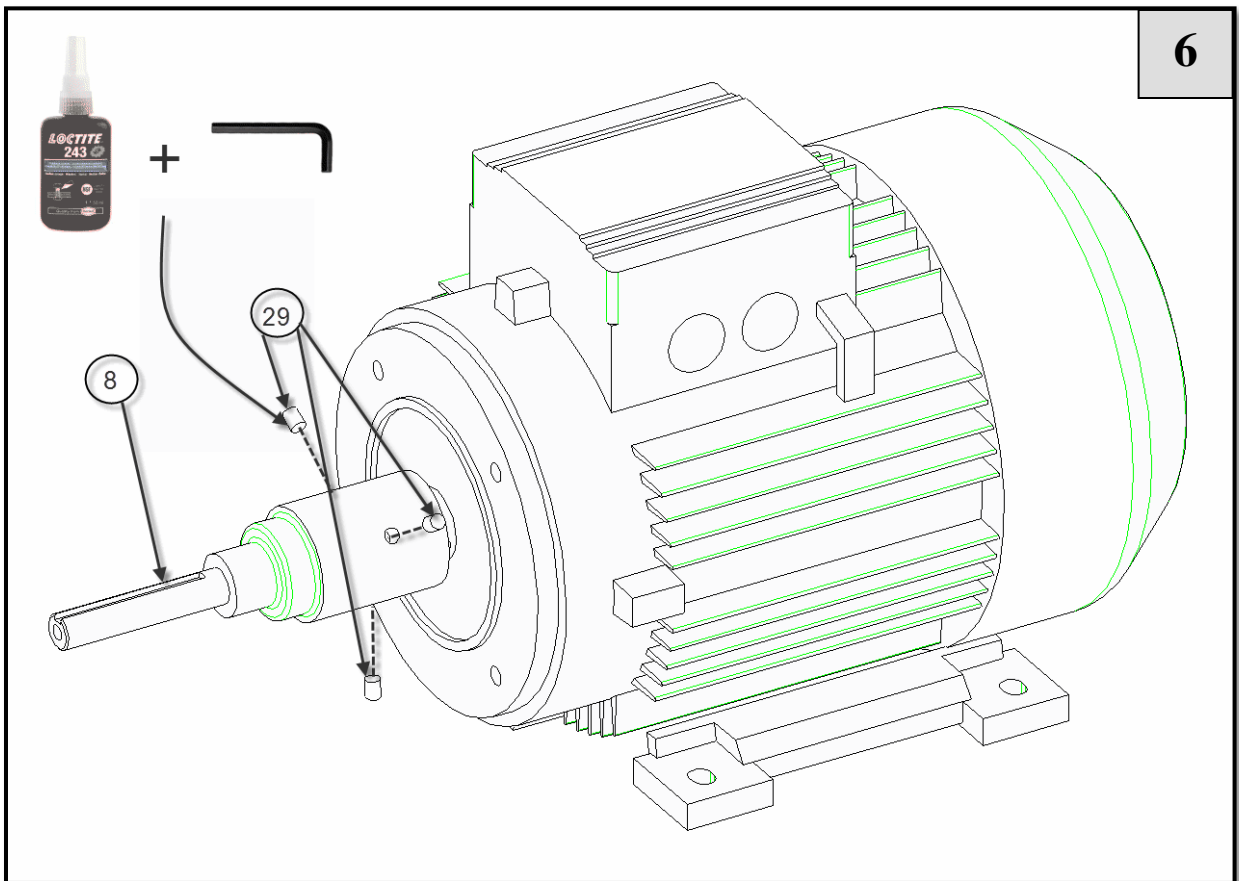
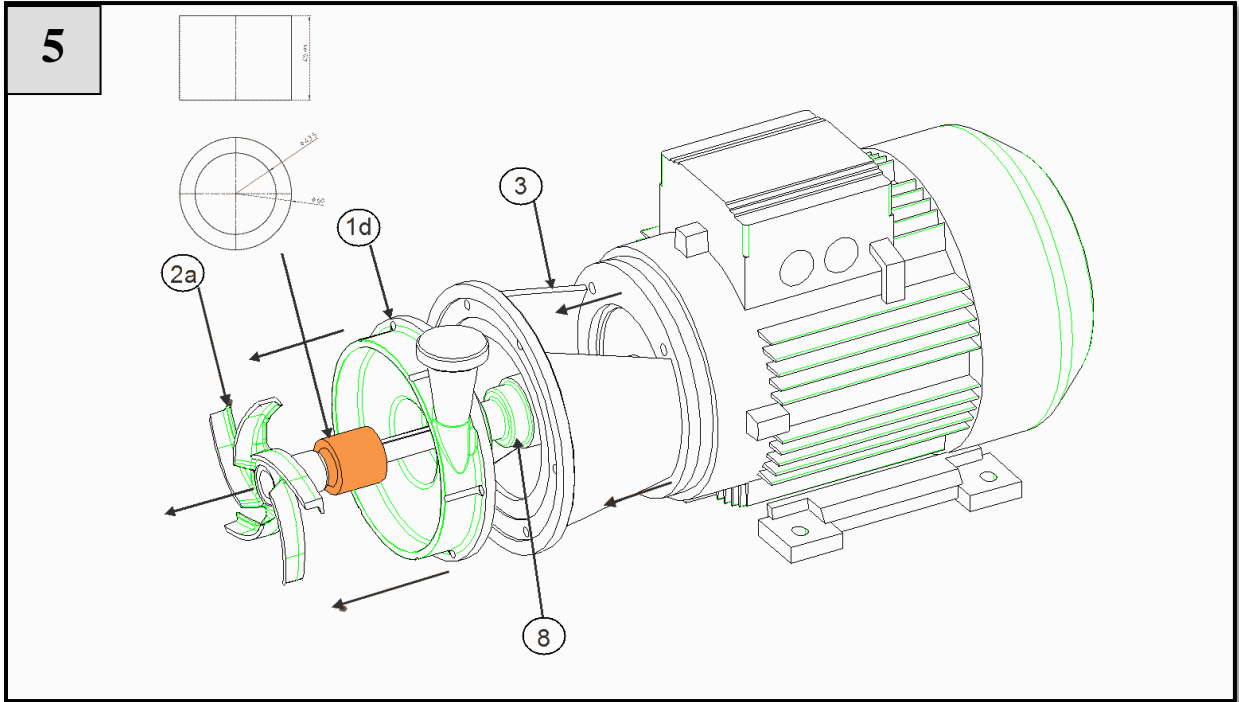

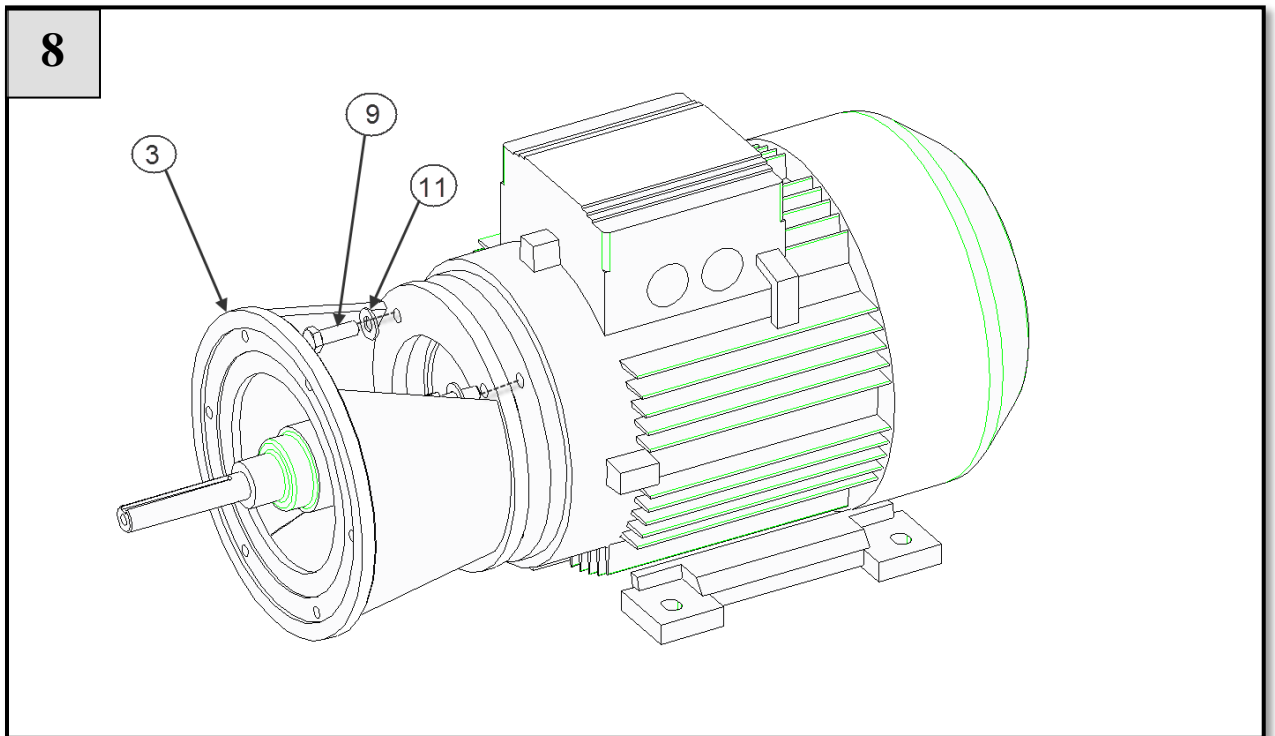
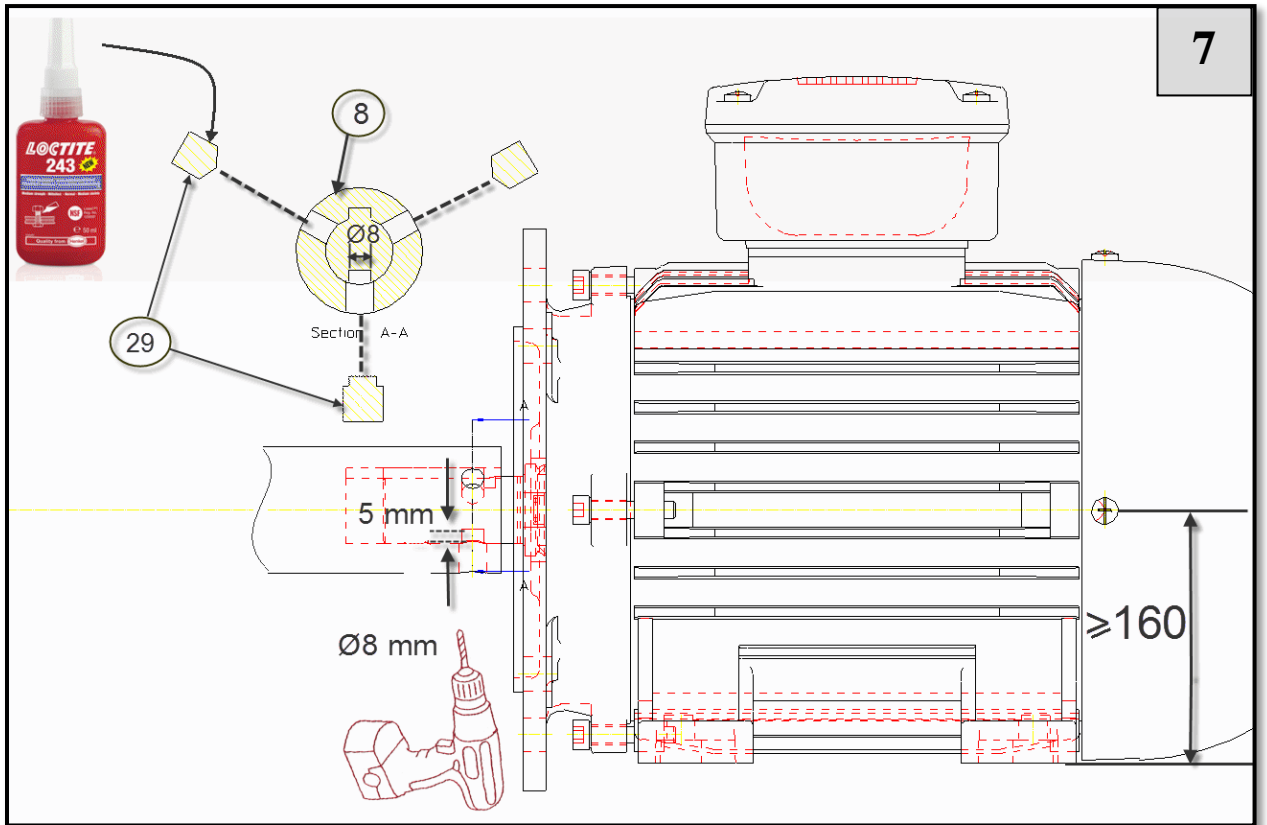

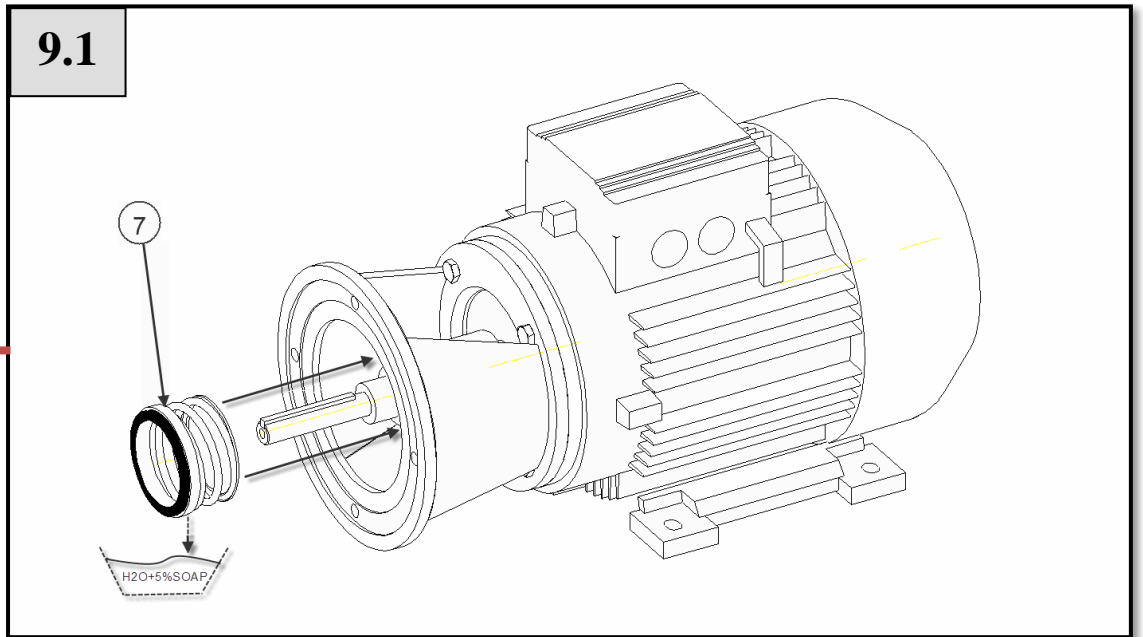
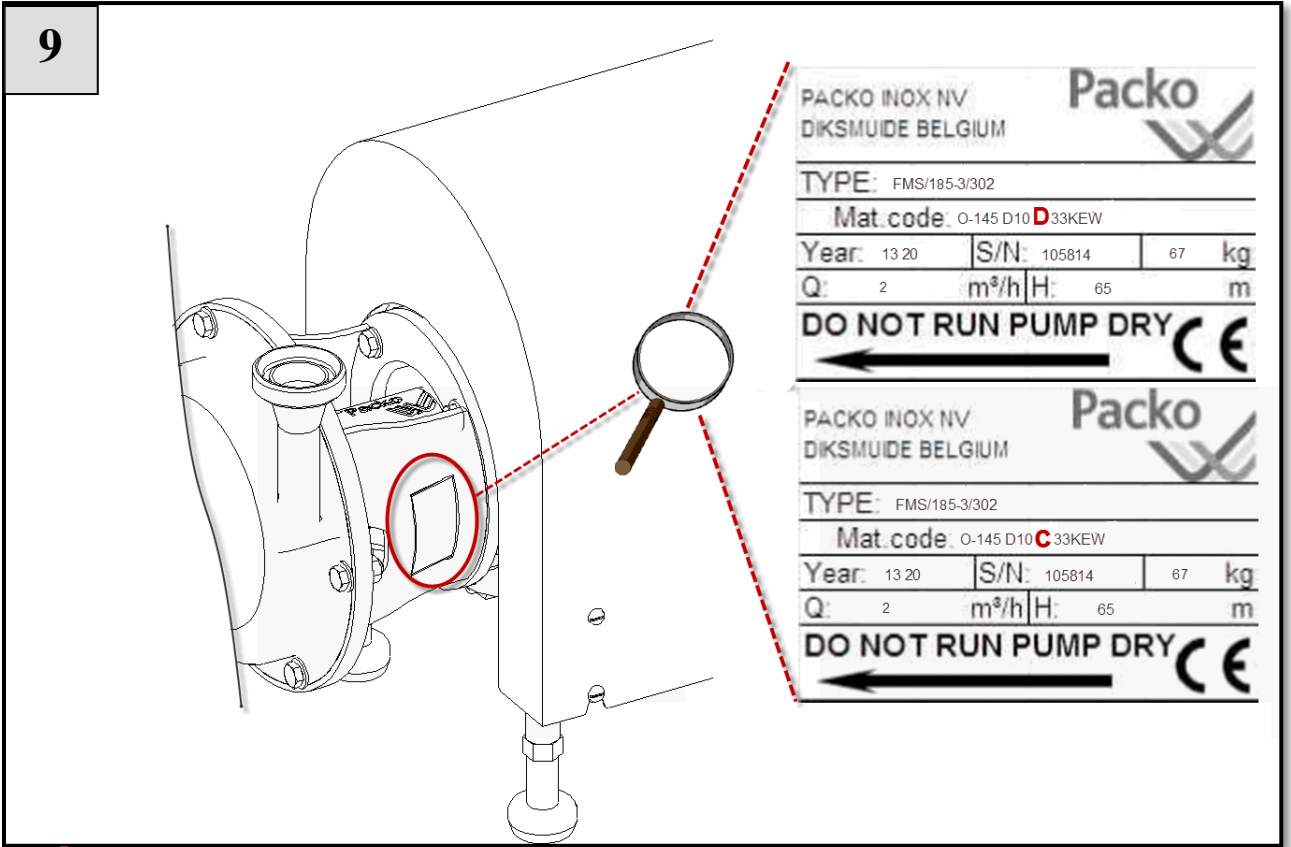

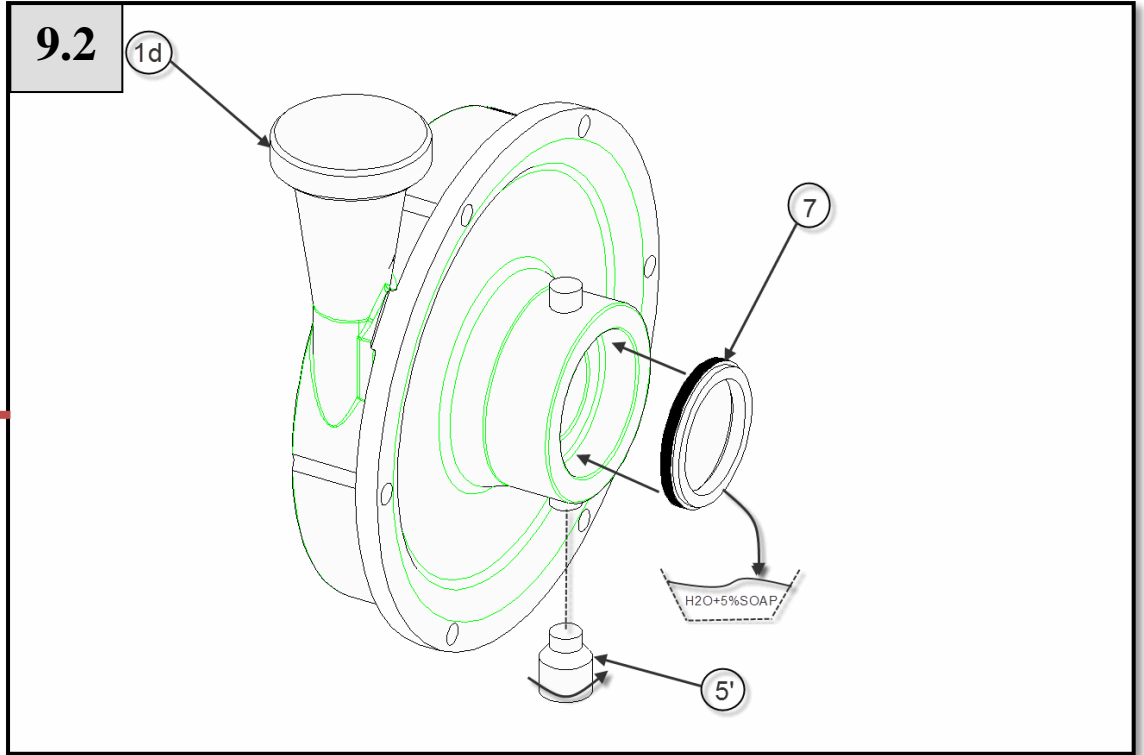

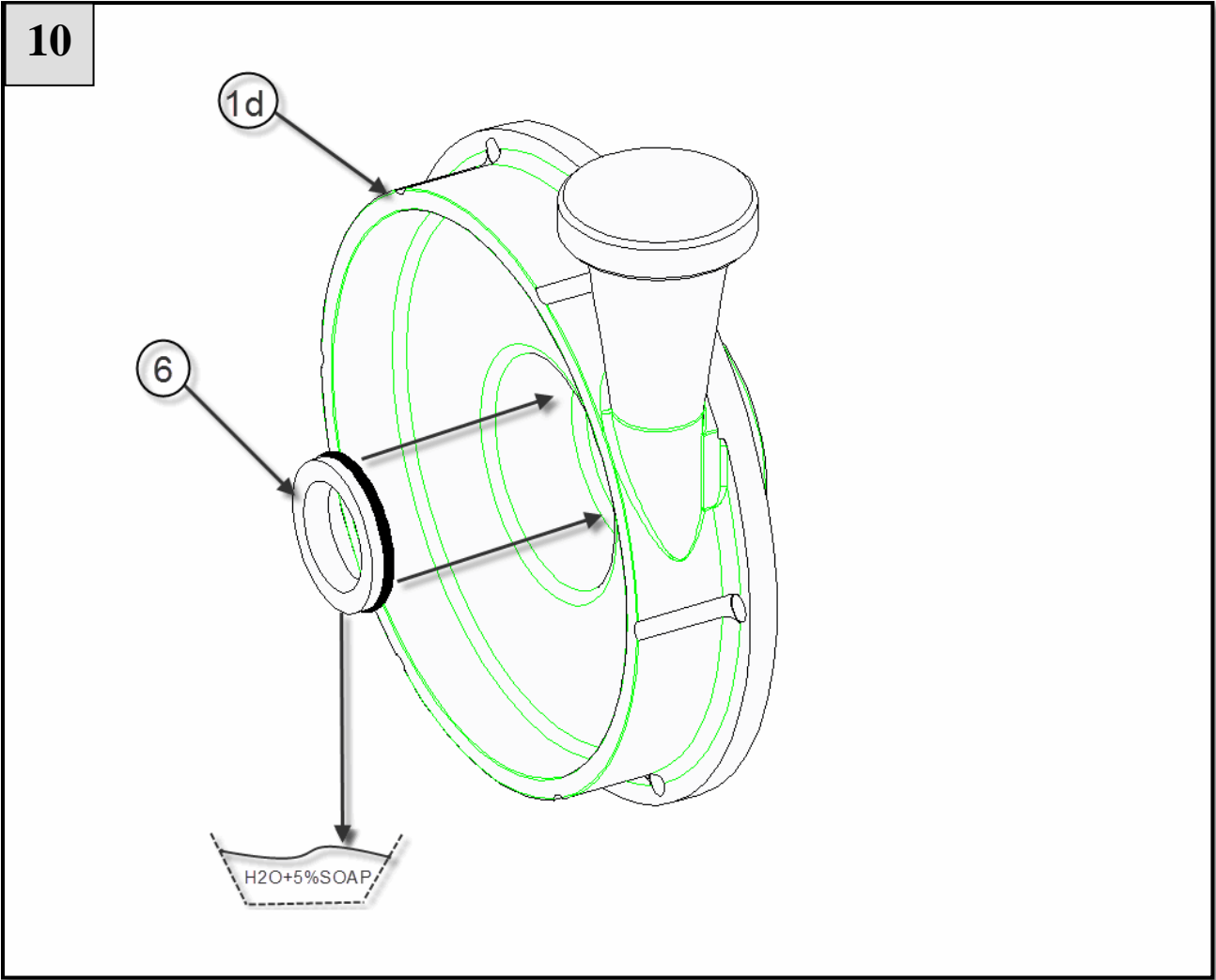

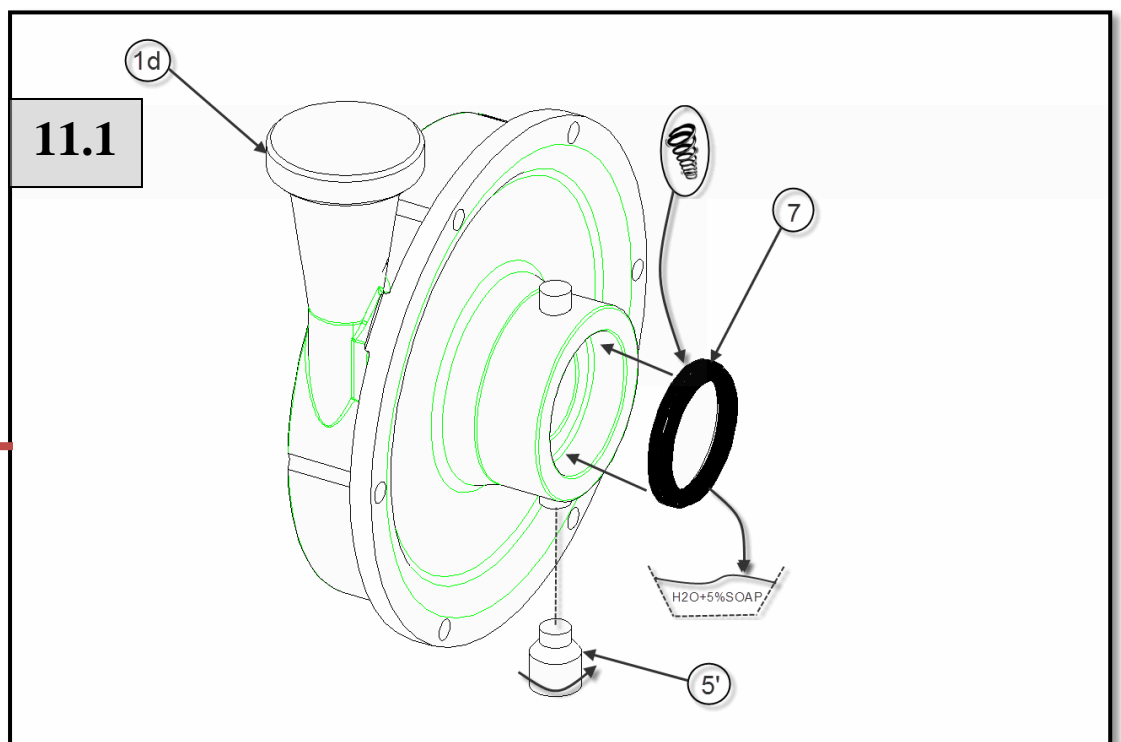
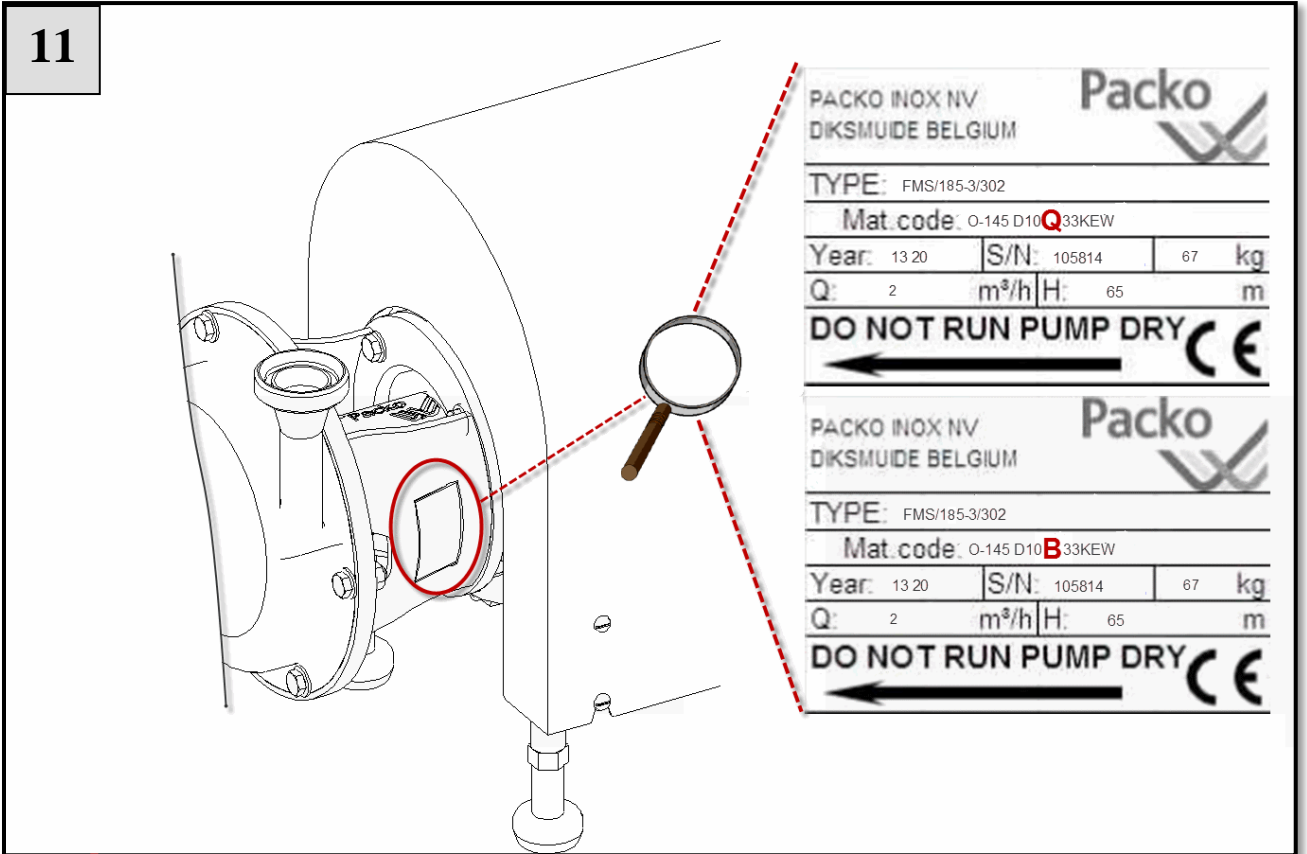

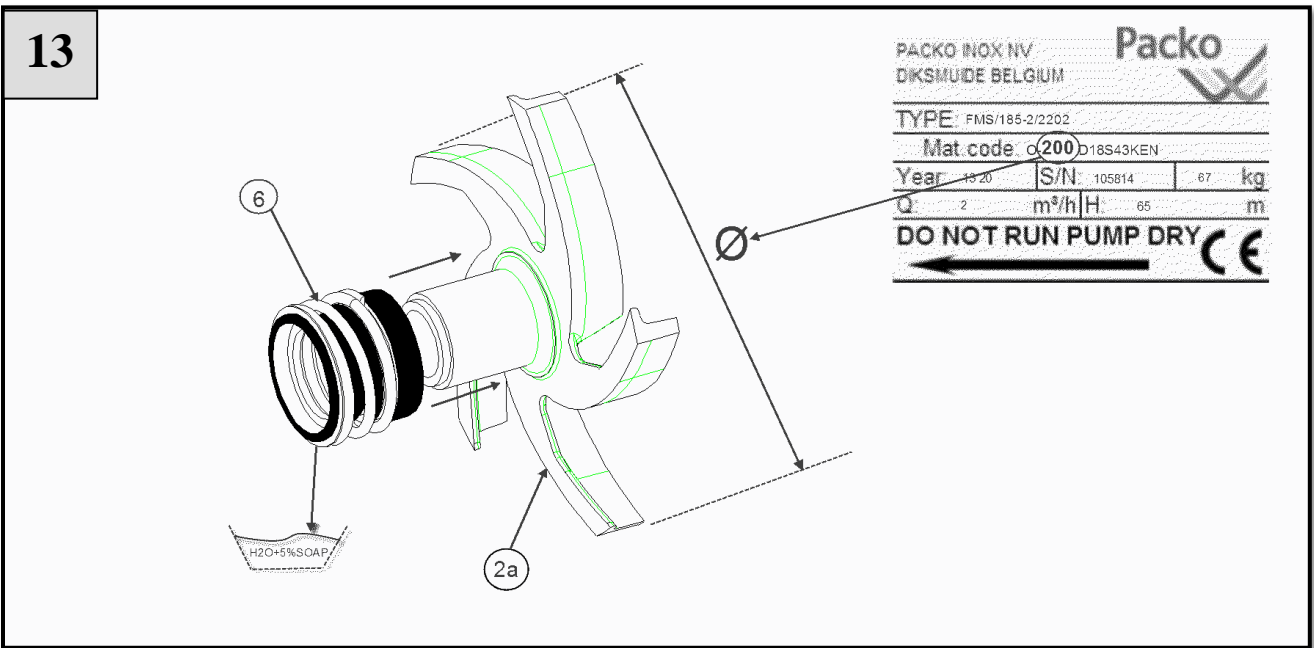
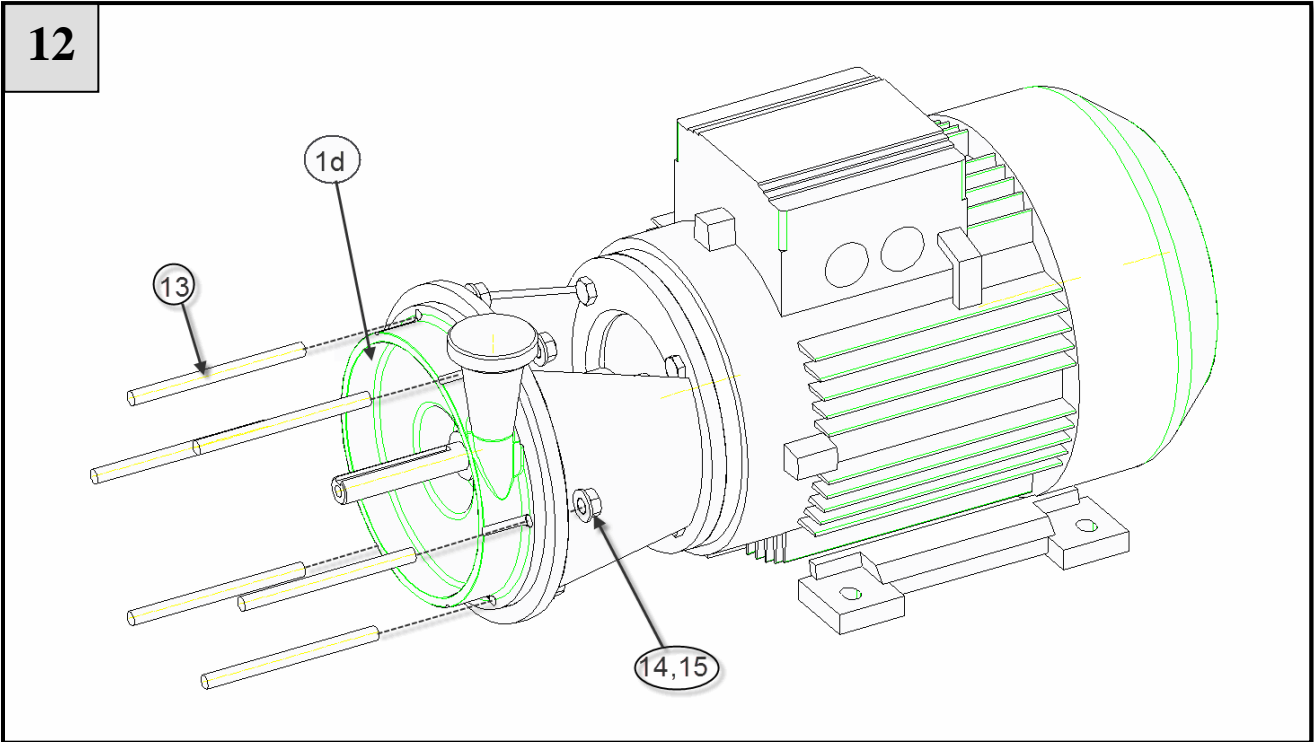

14

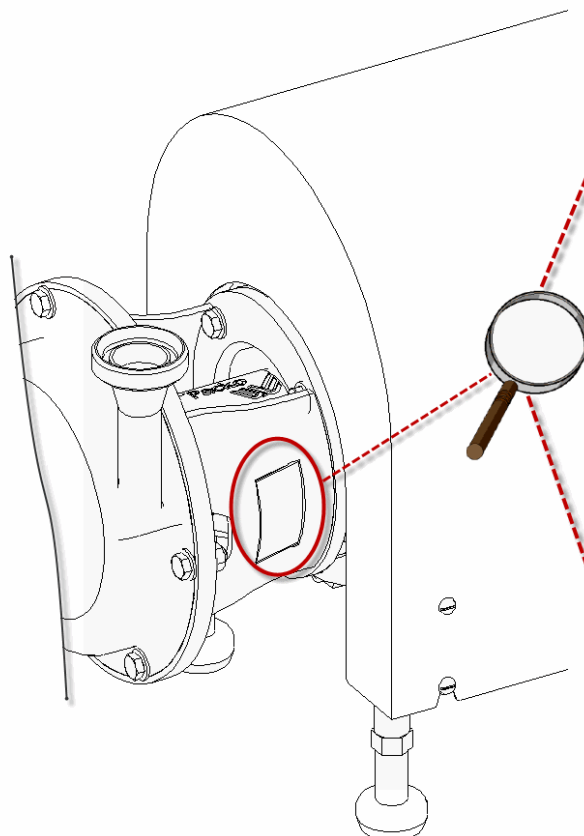

PACKO INOX NV DIKSMUDE BELGIUM		Packo	
TYPE: FMS/185-3/302			
Mat.code: O-145 D10 A 33KEW			
Year: 13 20	S/N: 105814	67	kg
Q: 2	m³/h	H: 65	m
PACKO INOX NV DIKSMUDE BELGIUM		Packo	
TYPE: FMS/185-3/302			
Mat.code: O-145 D10 B 33KEW			
Year: 13 20	S/N: 105814	67	kg
Q: 2	m³/h	H: 65	m
PACKO INOX NV DIKSMUDE BELGIUM		Packo	
TYPE: FMS/185-3/302			
Mat.code: O-145 D10 C 33KEW			
Year: 13 20	S/N: 105814	67	kg
Q: 2	m³/h	H: 65	m

14.1

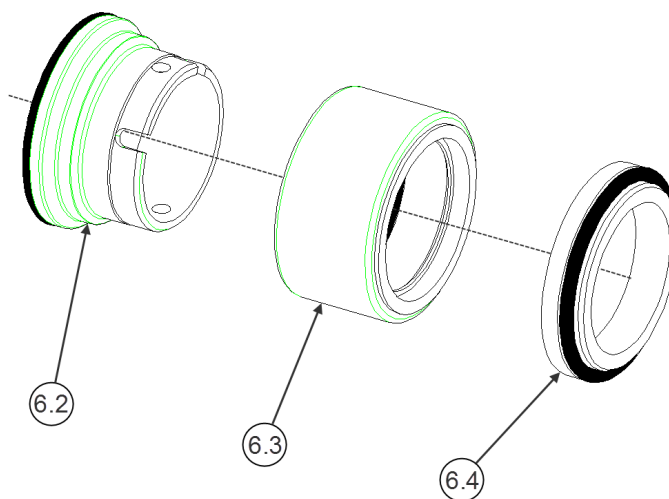

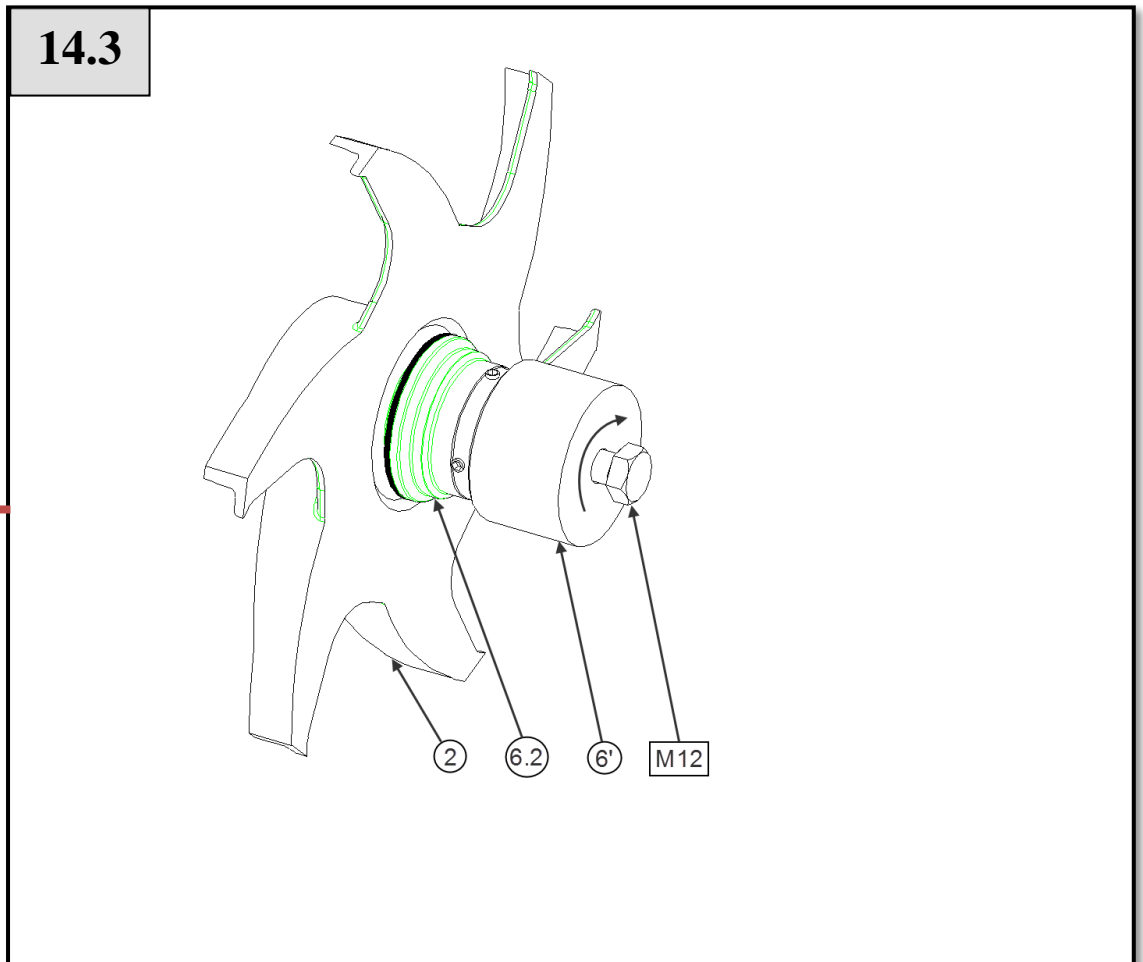
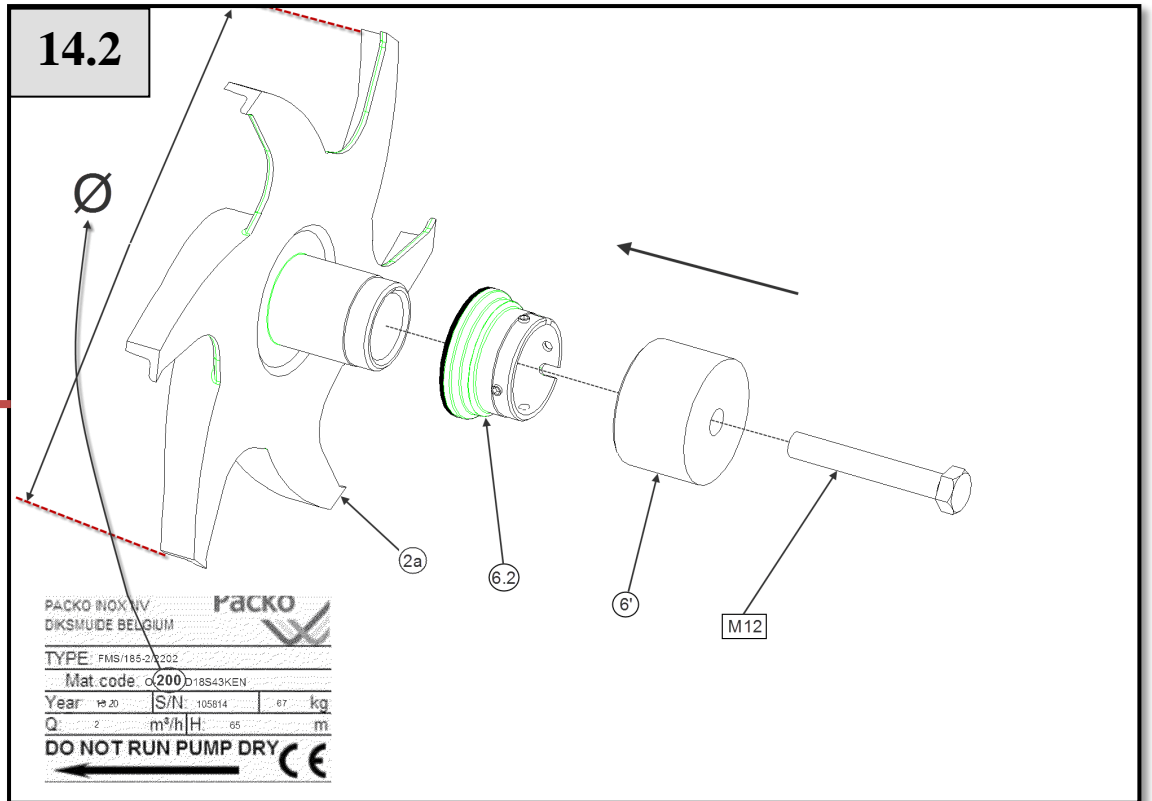

14.4

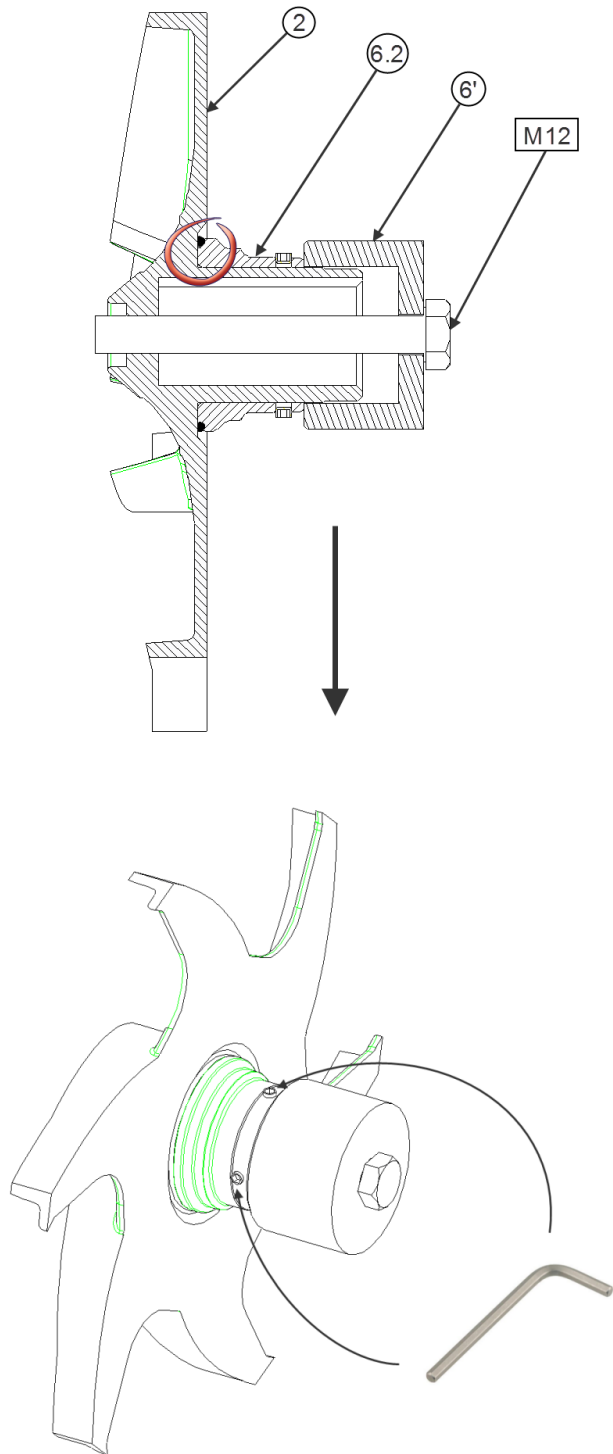

14.5

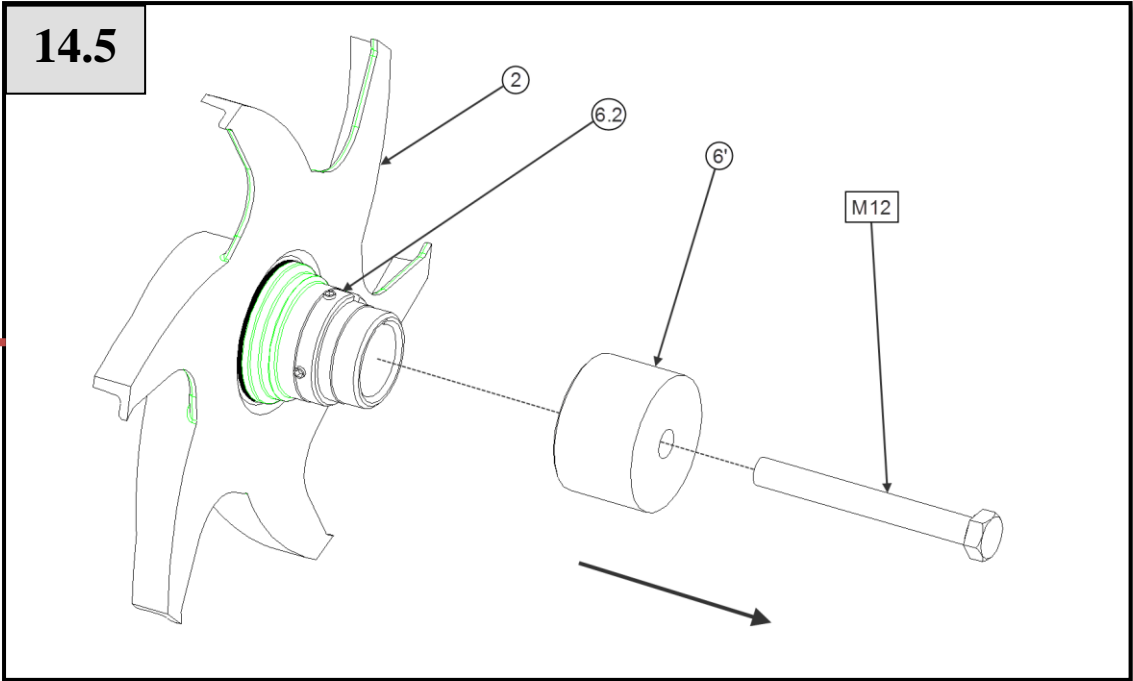

14.6

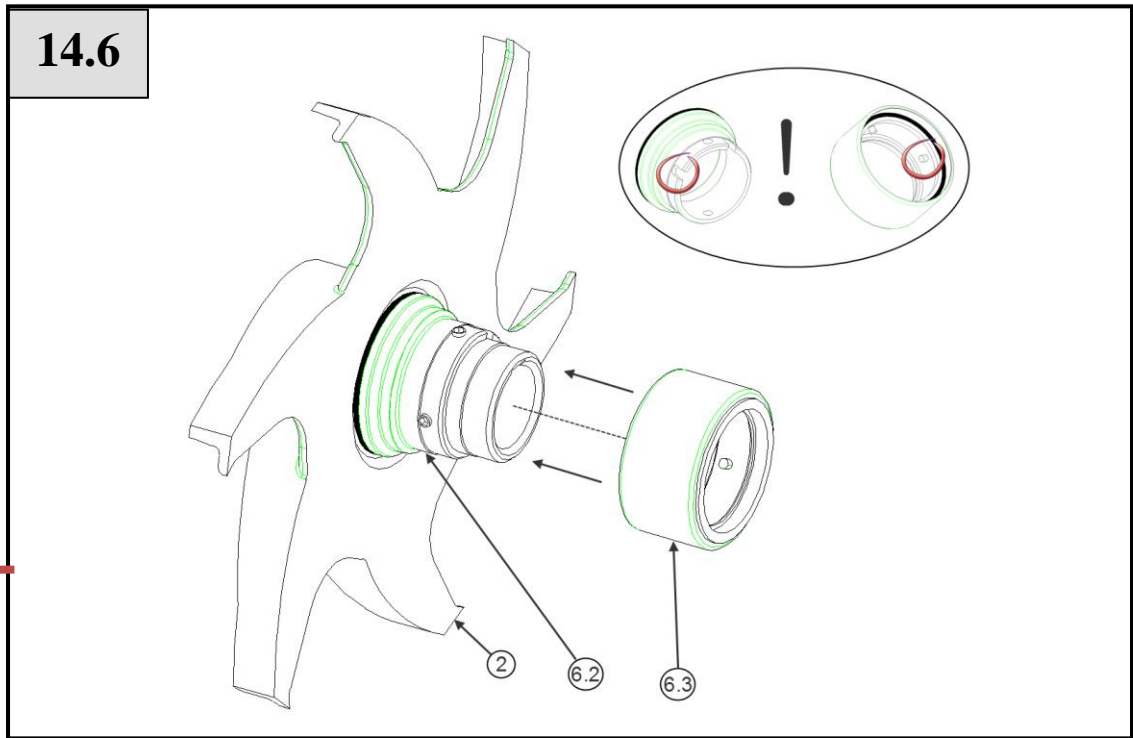

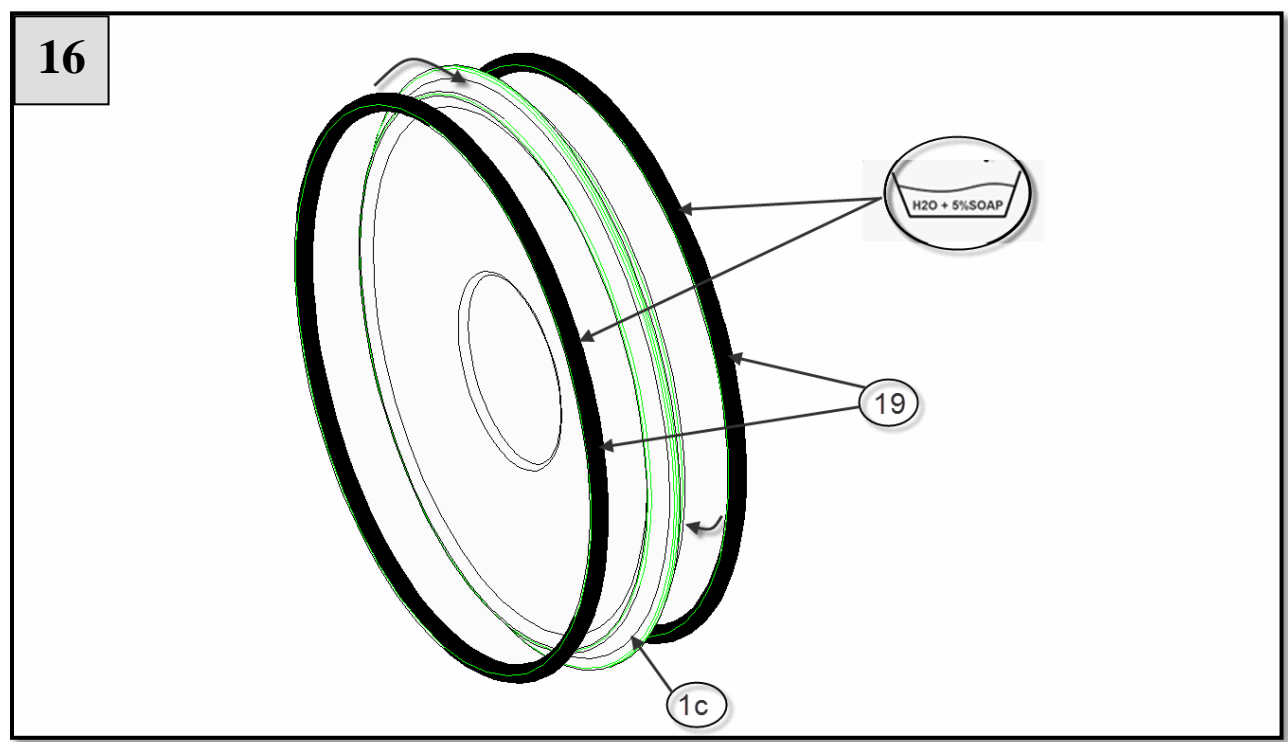
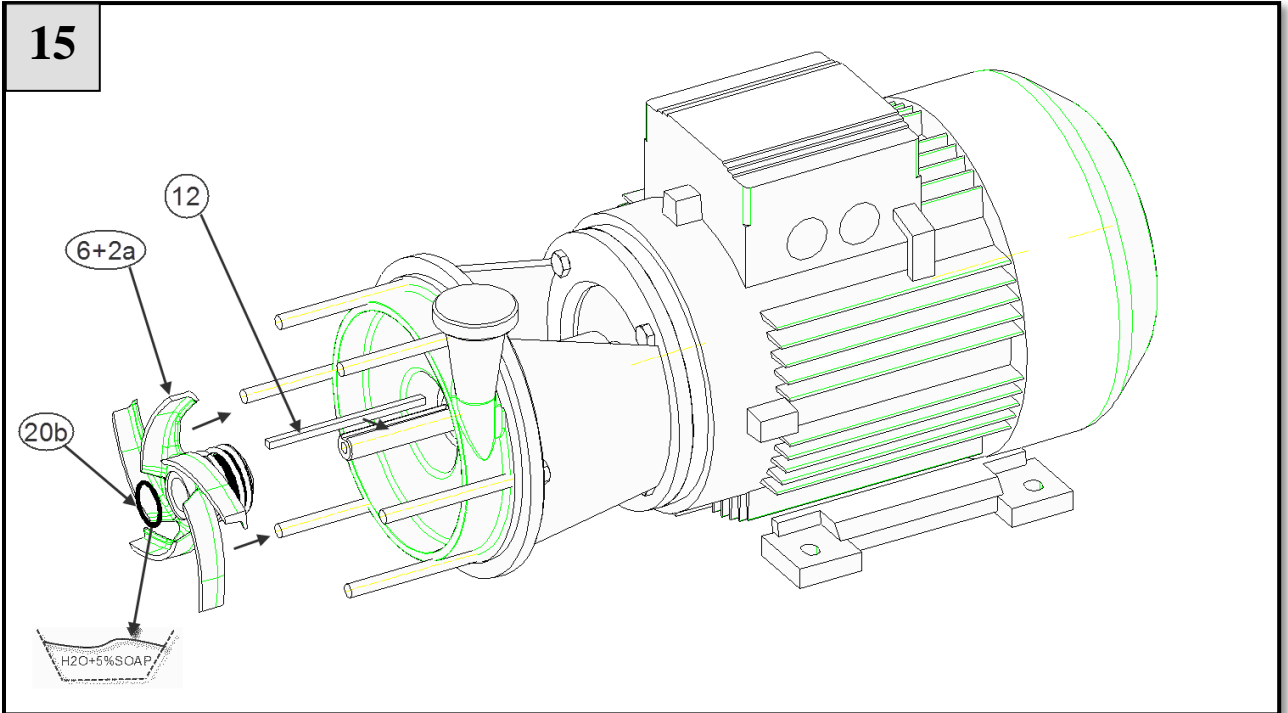

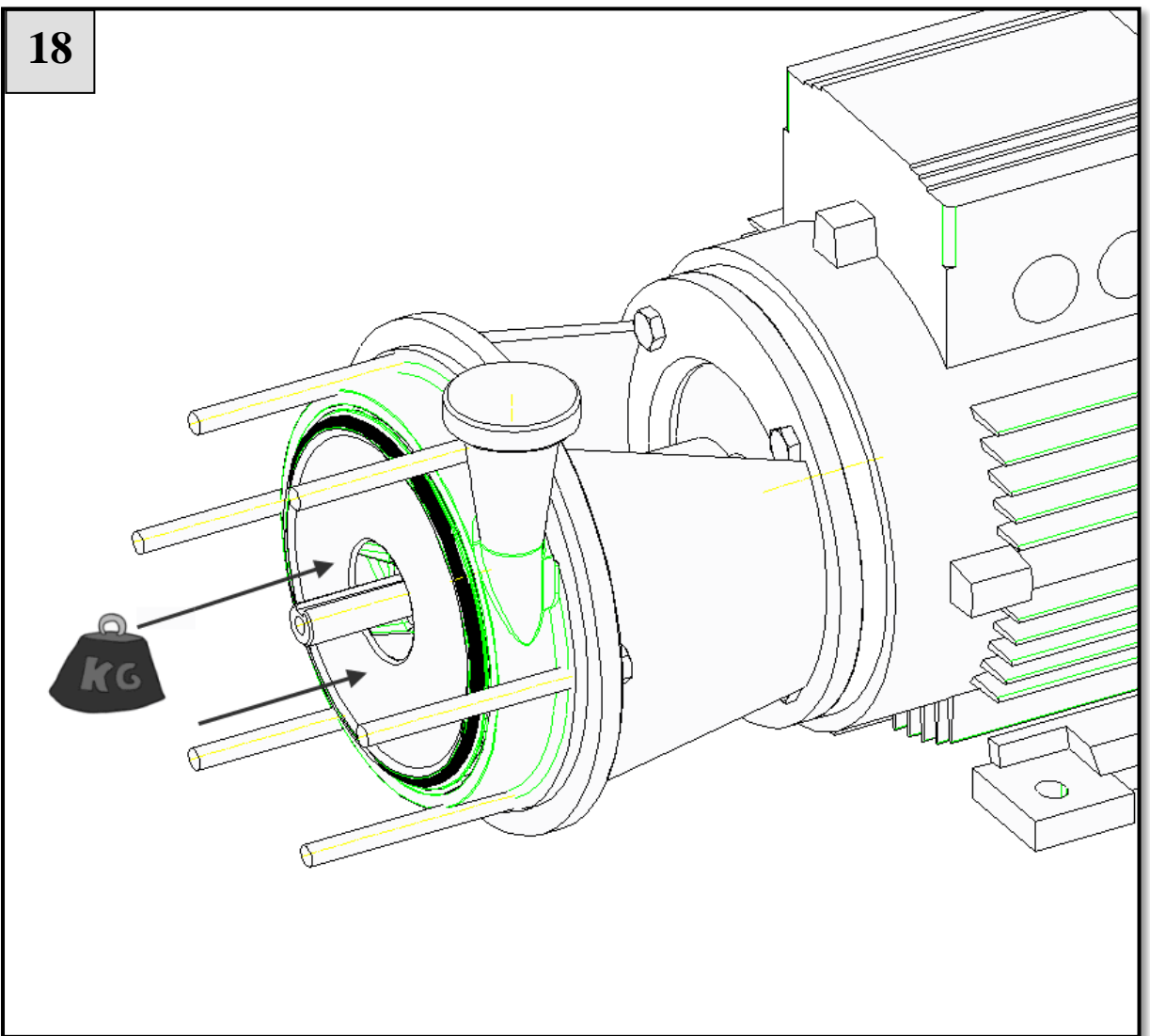
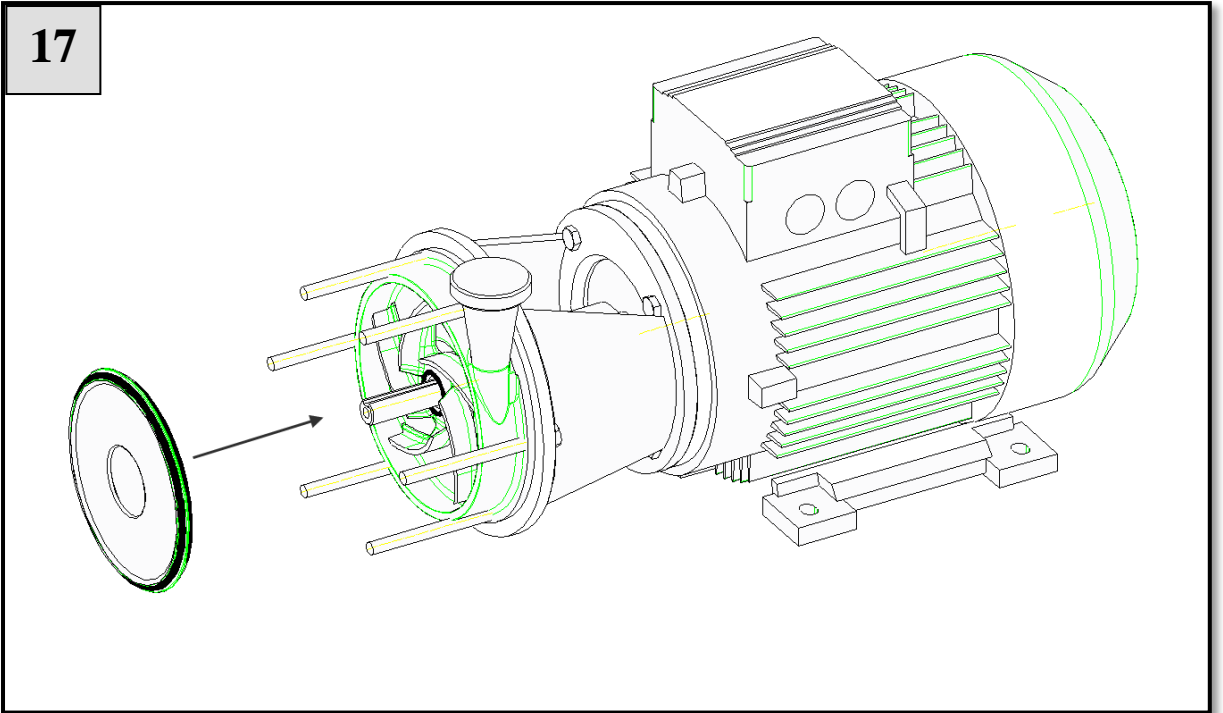

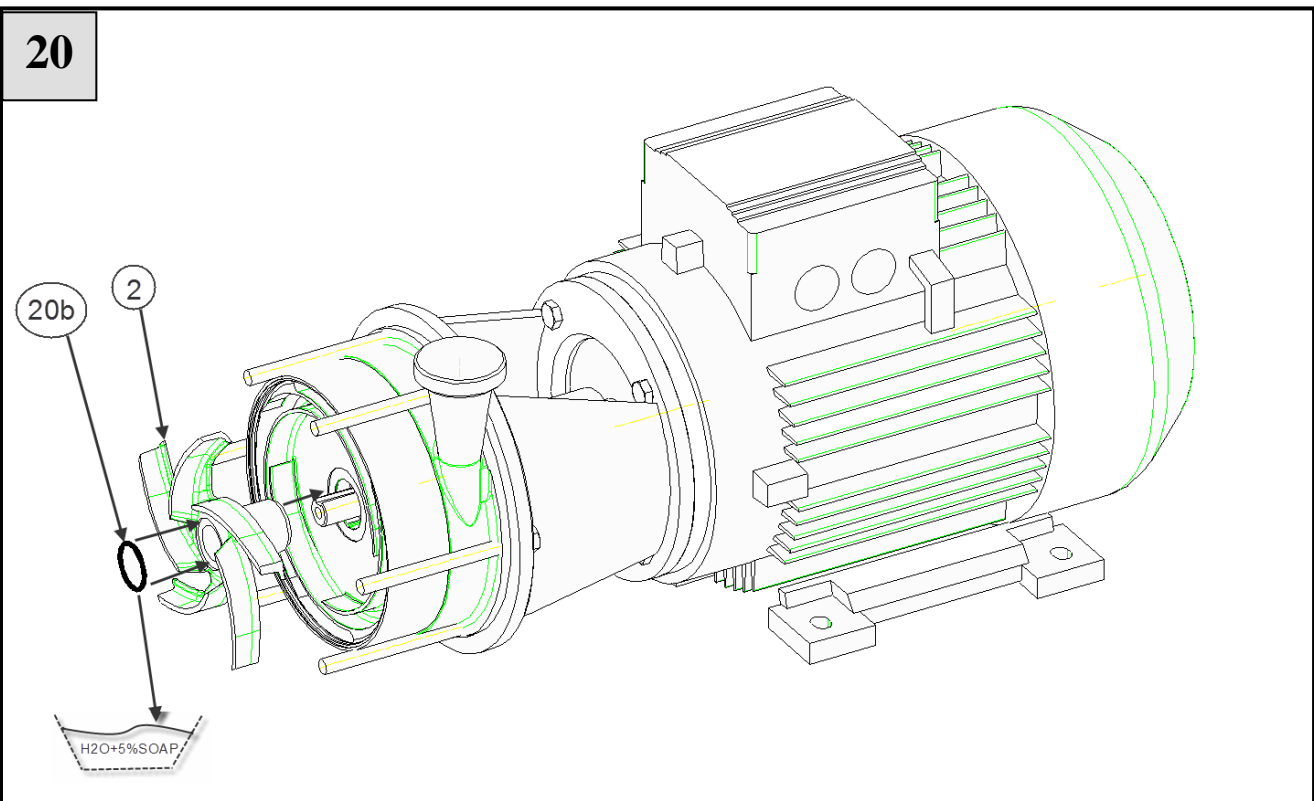
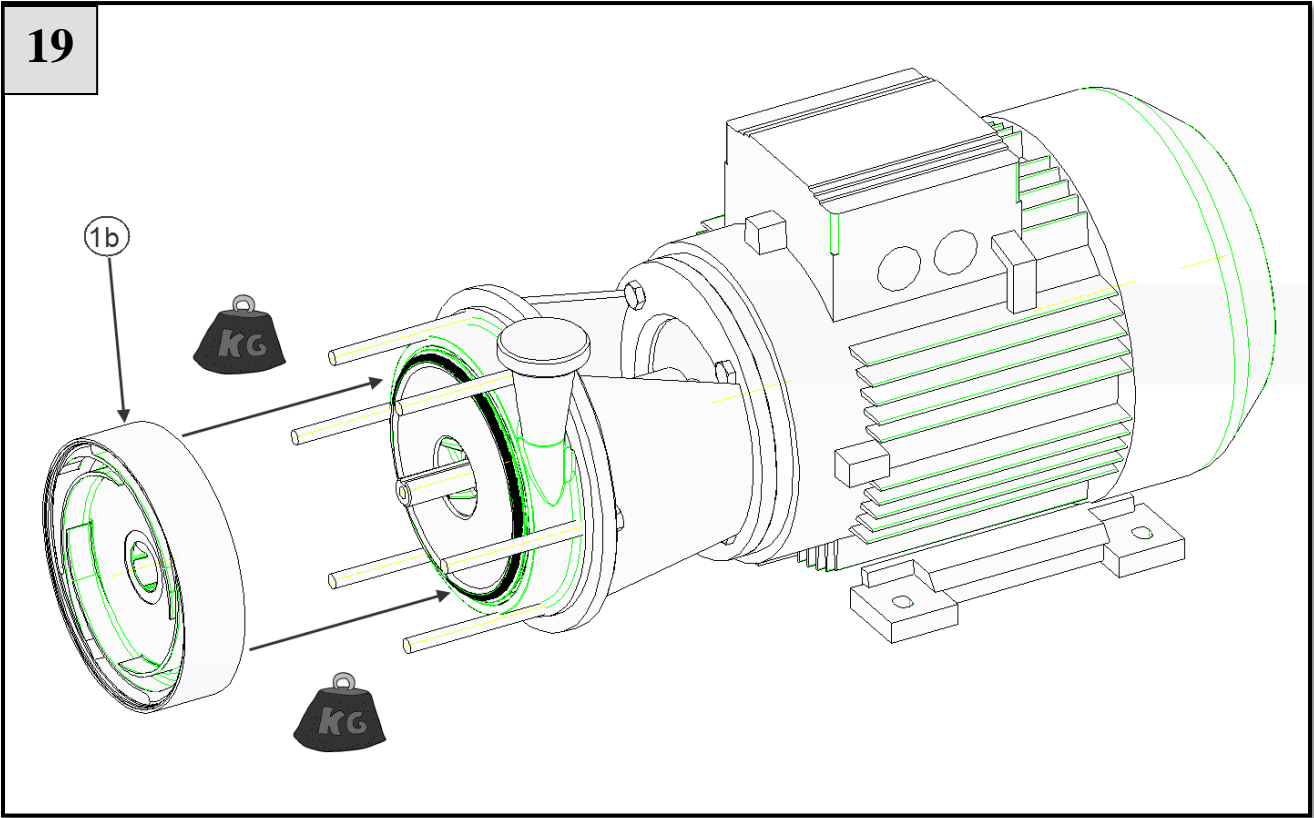

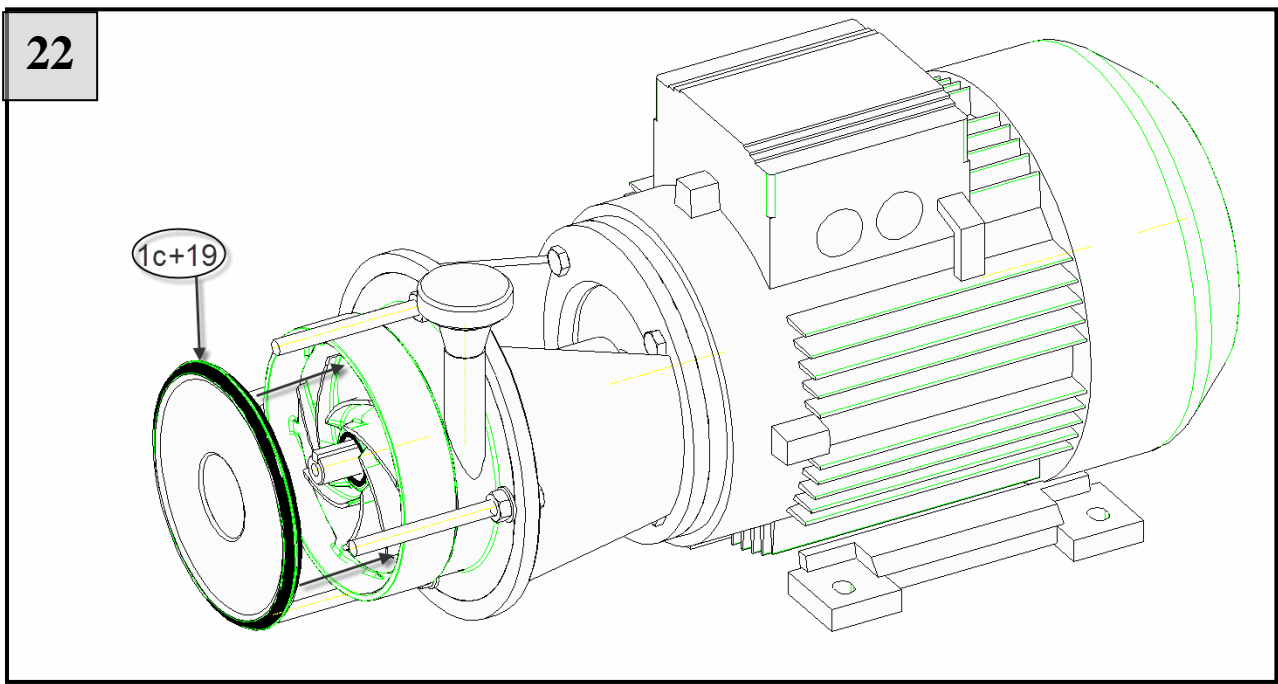
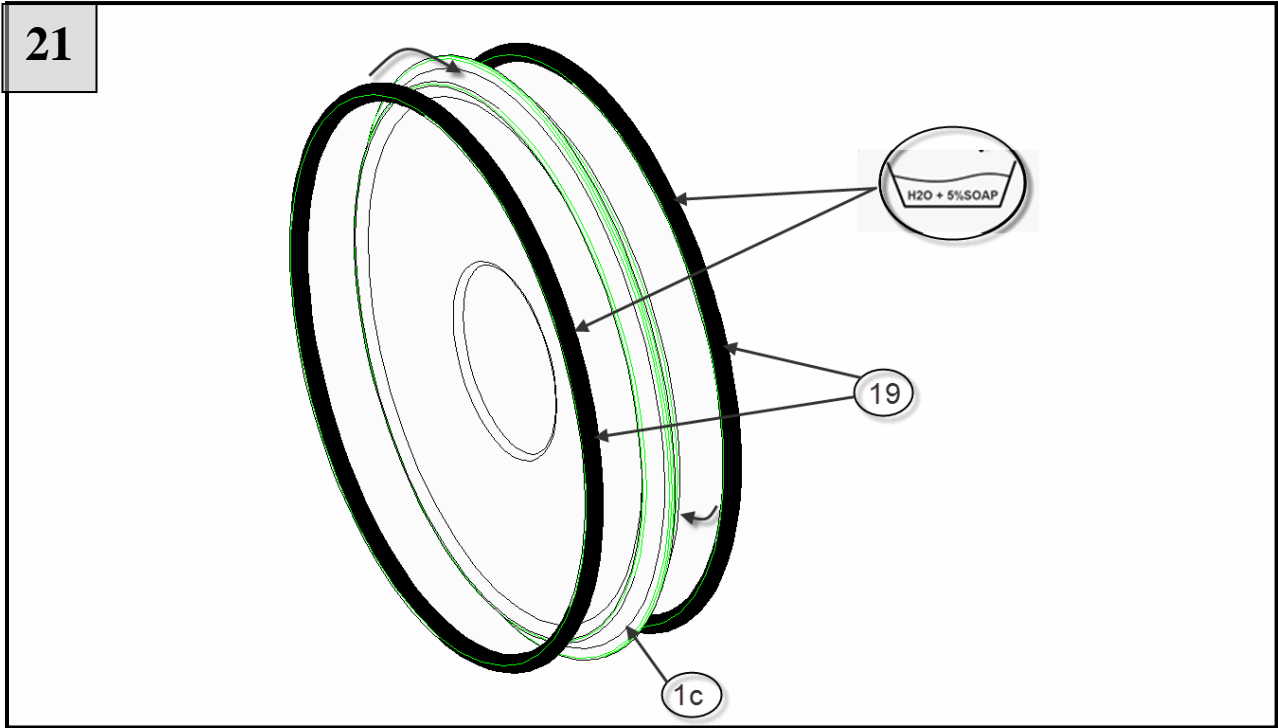

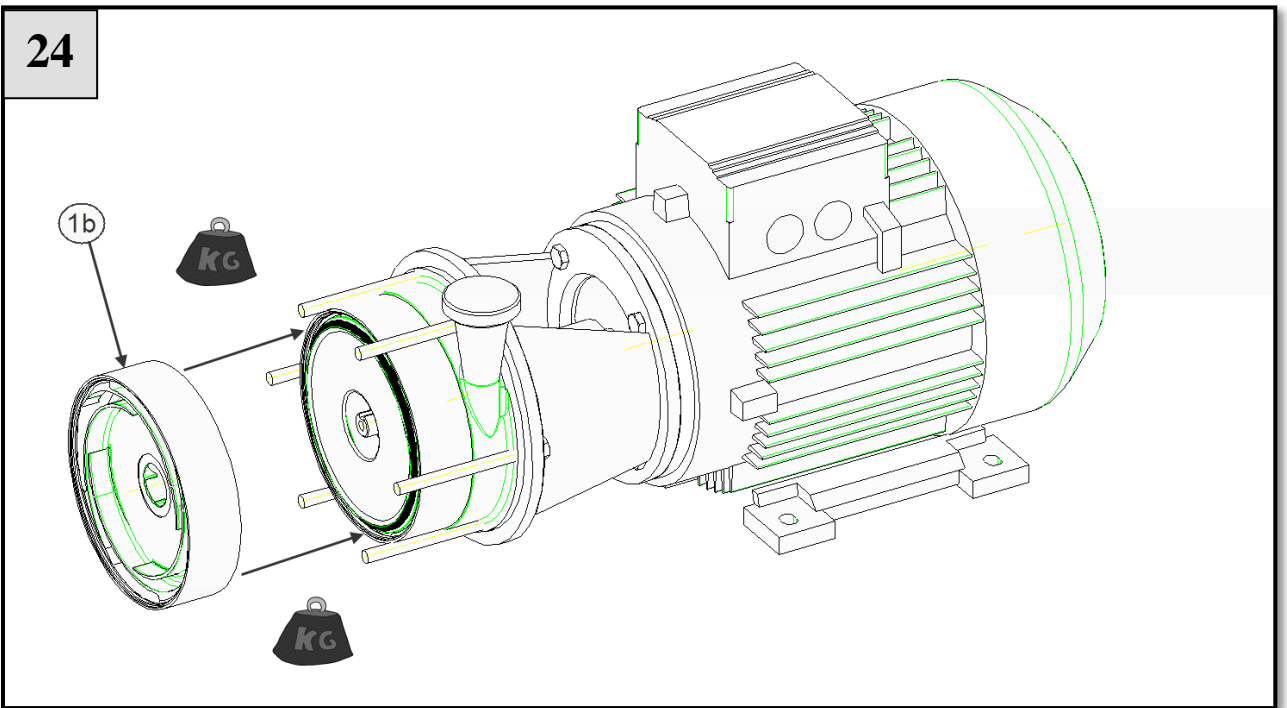
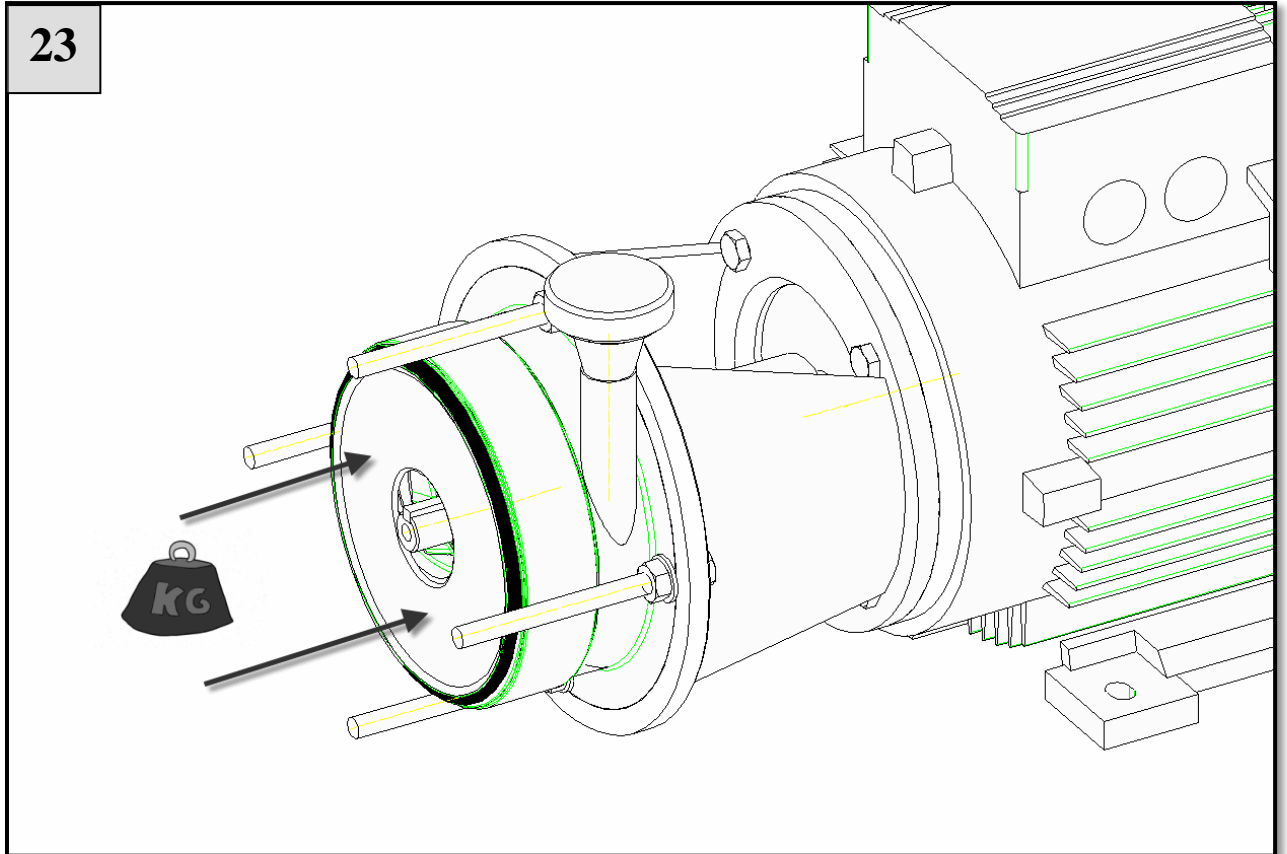

25

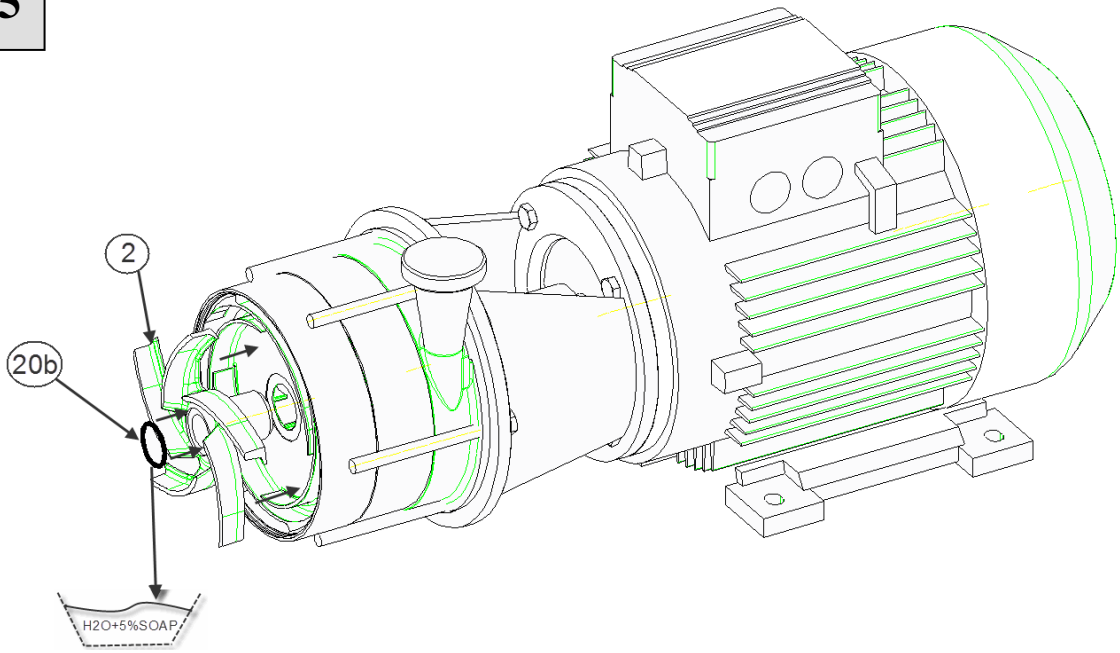

26

