

Verderdos

VE Dual pH-Redox dosing pump



VERDERDOS

Description

The VE Dual pH-chlorine is a compact dosing system with built-in controller and two solenoid dosing pumps, capable of reading and adjusting pH and Redox parameters in water. Fully programmable, it is the perfect all in one solution for water disinfection with the exclusive function pH stability only available on the dual line of products.

Features

- Double system with built in ph Redox and T° controller
- Flow rate display in percentage
- 3 different functioning mode: constant, ON / OFF, proportional
- Menu available in 4 languages: ITALIAN, ENGLISH, FRANCE, SPANISH
- Password protected
- Start up delay
- Overdose time alarm
- Default parameter restore option
- pH Stability mode
- STAND BY modality
- Over / under range signal
- Backlit LCD
- PP reinforced case
- IP 65
- 230vac 50-60 Hz standard power supply
- Level probe input
- Flow sensor input
- ON / OFF switch

Materials

Specifications	Standard	Optional
Pump head	PVDF fittings 1/2"	PP fittings 1/2"
Balls	Pyrex	Ceramic, PTFE, AISI 316
Diafraghm	PTFE	-
Fittings	PVDF	PP
Seals	Viton®	EPDM
Valve cartridge	PVDF 4 x 6	PP 4 x 6
Foot filter	PVDF 4 x 6 lip valve	PP 4 x 6 ball valve
Injection valve	PVDF fittings 4 x 6 lip valve	PP 4x6 ball valve
Suction tube	PVC 4 x 6	PVDF 4 x 6
Delivery tube	PE 4 x 6	PVDF 4 x 6

	PTFE BALLS	SS 316 BALLS	PYREX BALLS	CERAMIC BALLS
Material	PTFE	SS 316	DURAN – PYREX	AL ² O ³
Hardness	60 (D)	1407160 HB	± 45 HRC	± 45 HRC
Specific weight	2.10 g/cm ³	8.02 g/cm ³	2.23 g/cm ³	3.90 g/cm ³
Description	Resistant to most of oxidizing chemicals, inorganic salt solutions, hydrocarbons. Non-conductive.	Spheres with resistance to corrosion caused by chemical solutions oxidants, organic chemicals, sterile solutions, mineral water and sea water, ammonia, salt air, etc.	Spheres with excellent chemical inertness to most acids. Excellent for use in metering pumps and valves in contact with strong oxidizing concentrations.	Resistant to most corrosive agents. Not recommended for use with hydrochloric acid and hydrofluoric acid solutions. Maximum abrasion resistance.

Technical data

Standard	Flow max l/h	Pressure bar	Max cc / imp	Stroke	Solenoid	Body pump	Power c Watt	Pulses ppm	Weight kg
Chlorine	10	2	1,11	1.3	Ø 80	PVDF	60	150	8
pH pump	5	10	0,55	1.1	Ø 80	PVDF	60	150	8

Verderdos

VE Dual pH-Redox dosing pump

VERDERDOS



Dimensions

(in mm)

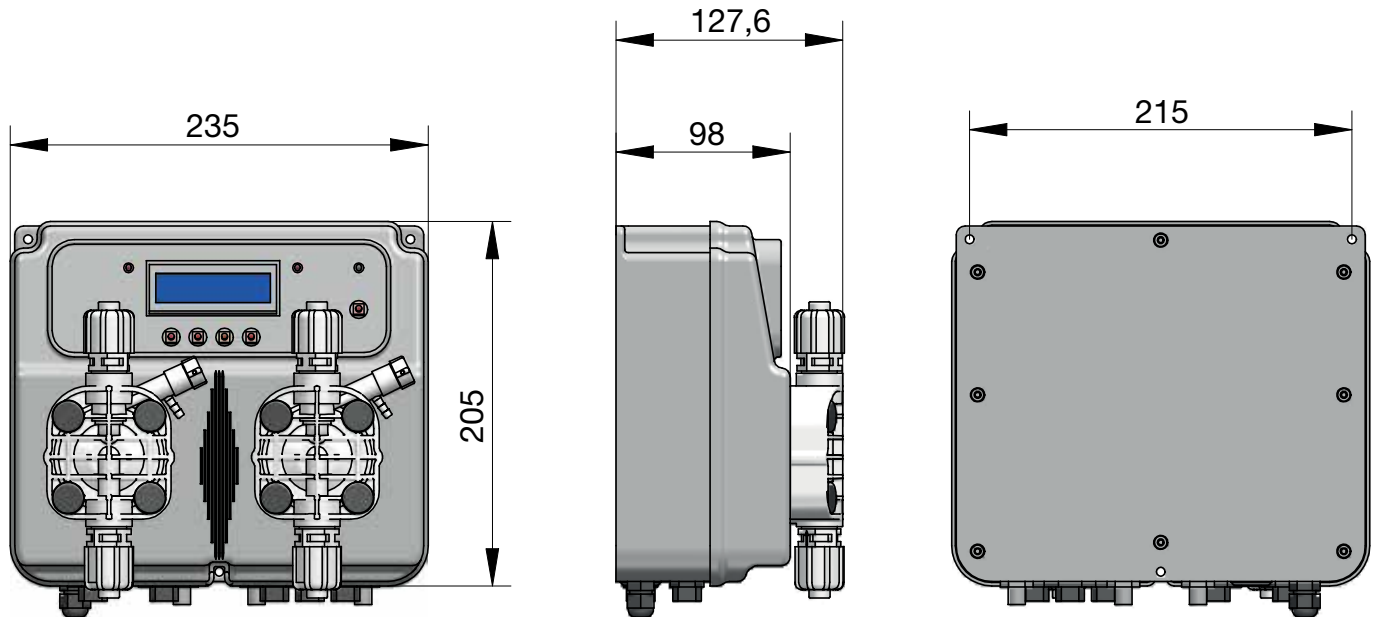

Standard installation kit

PVDF Injection valve SP VITON	PVDF foot filter SP VT	Delivery tube 2 m PE 4x6	Suction tube 2 m PVC 4x6	Bleed tube 1.5 m PVC 4x6
				

Accessories

- Probes (ph/Redox/Chlorine Cells)
- Probe holders
- Suction lances
- Mixers
- Tanks & bunds
- Water Meters

Find your local supplier
at www.verderdos.com

For construction, installation and mounting drawings
please contact your local authorised Verderdos distributor.

VERDER
passion for pumps

