

Verder HI-CLEAN VA-H25, VA-H40, and VA-H50 Diaphragm Pumps

819.0417

Rev. K
EN

For use in sanitary applications. For professional use only.



Important Safety Instructions

Read all warnings and instructions in this manual. Save these instructions.

Refer to page 3 for Pump Configuration information and to page 4 for available models and approval information.

8 bar (0.8 MPa, 120 psi) Maximum Fluid Working Pressure
8 bar (0.8 MPa, 120 psi) Maximum Air Input Pressure

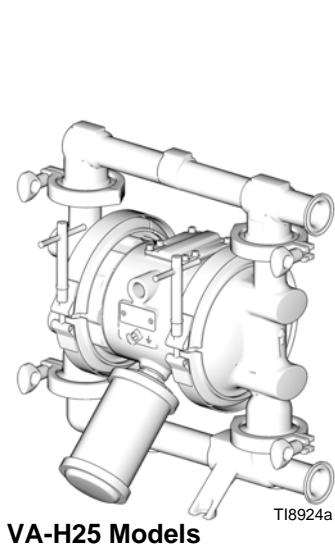

VA-H25 Models

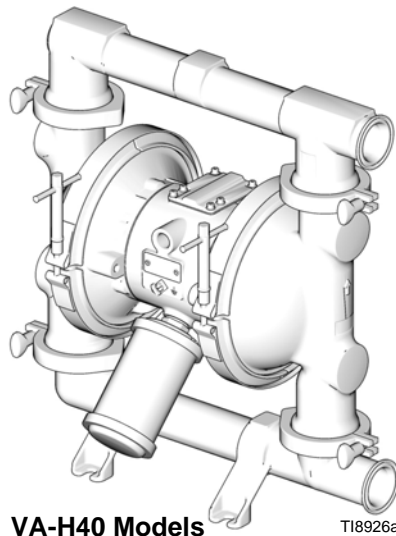

VA-H40 Models

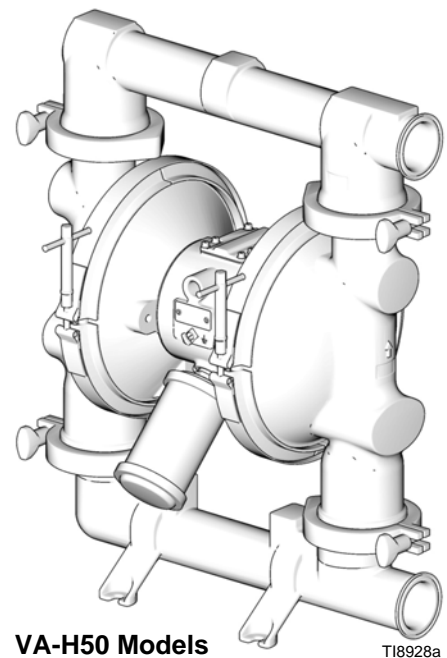

VA-H50 Models



II 2 GD
Ex h IIC 66°C...135°C Gb
Ex h IIIC T135°C Db

Contents

Pump Configuration	3	Manifold O-Ring Kits	28
Available Verder HI-CLEAN Configurations	4	VA-H25 Fluid Section Repair Kits*	28
Warnings	5	Dimensional Drawing, VA-H25 Models	29
Installation	7	Technical Data, VA-H25 Models	30
General Information	7	Performance Chart, VA-H25 Models	31
Tighten Clamps Before First Use	7	Parts, VA-H40 Models	32
Grounding	7	Parts, VA-H40 Models, continued	33
Mountings	8	Air Motor	33
Air Line	8	Air Motor Common Parts	33
Fluid Suction Line	8	Fluid Section	33
Fluid Outlet Line	9	Seat	33
Air Exhaust Ventilation	11	Ball	33
Operation	12	Diaphragm	34
Pressure Relief Procedure	12	Manifold O-Ring Kits	34
Sanitize the Pump Before First Use	12	VA-H40 Fluid Section Repair Kits*	34
Starting and Adjusting the Pump	12	Dimensional Drawing, VA-H40 Models	35
Pump Shutdown	12	Technical Data, VA-H40 Models	36
Maintenance	13	Performance Chart, VA-H40 Models	37
Air Valve Lubrication	13	Parts, VA-H50 Models	38
Flushing	13	Parts, VA-H50 Models, continued	39
Tightening Connections	13	Air Motor	39
Preventive Maintenance Schedule	13	Air Motor Common Parts	39
Troubleshooting	14	Fluid Section	39
Service	16	Seat	39
Repairing the Air Valve	16	Ball	39
Ball Check Valve Repair	18	Diaphragm	40
Standard Diaphragm Repair	19	Manifold O-Ring Kits	40
Overmolded Diaphragm Repair	22	VA-H50 Fluid Section Repair Kits*	40
Bearing and Air Gasket Removal	24	Dimensional Drawing, VA-H50	41
Parts, VA-H25 Models	26	Technical Data, VA-H50 Models	42
Parts, VA-H25 Models, continued	27	Performance Chart, VA-H50 Models	43
Air Motor	27	Customer Services/Guarantee	45
Air Motor Common Parts	27		
Fluid Section	27		
Seat	27		
Ball	27		
Diaphragm	28		

Pump Configuration

Sample Configuration Number: VA-H40 SS ST TF TF T5 FD

VA-H	40	SS	ST	TF	TF	T5	FD
Pump Model	Size	Fluid Section and Air Section	Seats and O-Rings	Balls	Diaphragms	Connections	Pump Style

NOTE: Some combinations are not possible. For a list of current offerings, please see page 4. Also, please check with your local supplier or on www.verderair.com.





Pump Model	Size	Fluid Section and Air Section Material		Seats and O-Rings	
VA-H	25	SA	Stainless Steel pump with Aluminum Air Section	SE	Stainless Steel seats with EPDM o-rings
	40	SS	Stainless Steel Pump with Stainless Steel Air Section	ST	Stainless Steel seats with PTFE o-rings
	50				

Check Valve Balls		Diaphragm		Connections		Pump Style		Certification	
SP	Santoprene	SP	Santoprene	T4	Tri-clamp, 1.5 in.	FD	Foodgrade	31	EN 10204 type 3.1
TF	PTFE	TF	PTFE/EPDM 2-Piece Diaphragm	T5	Tri-clamp, 2 in.				
NW	Neoprene Weighted	TO	PTFE Overmolded	T6	Tri-clamp, 2,5 in.				
				D4	DIN 11851, 40 mm				
				D5	DIN 11851, 50 mm				
				D6	DIN 11851, 65 mm				

Available Verder HI-CLEAN Configurations

Sample Configuration Number: VA-H40 SS ST TF TF D4 FD



VA-H	40	SS	ST	TF	TF	D4	FD
Pump Model	Size	Fluid Section and Air Section	Seats and O-Rings	Balls	Diaphragms	Connections	Pump Style

Tri-Clamp Models		DIN Models		Approvals
Model	Configurator Number	Model	Configurator Number	
810.0792	VA-H25 SS ST TF TF T4 FD	810.0793	VA-H25 SS ST TF TF D4 FD	 EC 1935/2004   II 2 GD Ex h IIC 66°C...135°C Gb Ex h IIIC T135°C Db
810.0802	VA-H25 SA ST TF TF T4 FD	810.0803	VA-H25 SA ST TF TF D4 FD	
810.0794	VA-H25 SS ST TF TO T4 FD	810.0795	VA-H25 SS ST TF TO D4 FD	
810.0796	VA-H40 SA ST TF TF T5 FD	810.0797	VA-H40 SA ST TF TF D5 FD	
810.0798	VA-H40 SS ST TF TF T5 FD	810.0799	VA-H40 SS ST TF TF D5 FD	
810.0800	VA-H40 SS ST TF TO T5 FD	810.0801	VA-H40 SS ST TF TO D5 FD	
810.0929	VA-H40 SA ST TF TO T5 FD			
810.0816	VA-H50 SA ST TF TF T6 FD	810.0817	VA-H50 SA ST TF TF D6 FD	
810.0820	VA-H50 SS ST TF TF T6 FD	810.0821	VA-H50 SS ST TF TF D6 FD	
810.0822	VA-H50 SS ST TF TO T6 FD	810.0823	VA-H50 SS ST TF TO D6 FD	
810.0804	VA-H25 SA SE NW SP T4 FD	810.0805	VA-H25 SA SE NW SP D4 FD	  II 2 GD Ex h IIC 66°C...135°C Gb Ex h IIIC T135°C Db
810.0806	VA-H25 SA SE SP SP T4 FD	810.0807	VA-H25 SA SE SP SP D4 FD	
810.0808	VA-H25 SS SE SP SP T4 FD	810.0809	VA-H25 SS SE SP SP D4 FD	
810.0810	VA-H40 SA SE NW SP T5 FD	810.0811	VA-H40 SA SE NW SP D5 FD	
810.0812	VA-H40 SA SE SP SP T5 FD	810.0813	VA-H40 SA SE SP SP D5 FD	
810.0814	VA-H40 SS SE SP SP T5 FD	810.0815	VA-H40 SS SE SP SP D5 FD	
810.0818	VA-H50 SA SE TF SP T6 FD	810.0819	VA-H50 SA SE TF SP D6 FD	









ATEX T-code rating is dependent on the temperature of the fluid being pumped. Fluid temperature is limited by the materials of the pump interior wetted parts. See **Technical Data** for the maximum fluid operating temperature for your specific pump model.

Warnings

The following warnings are for the setup, use, grounding, maintenance, and repair of this equipment. The exclamation point symbol alerts you to a general warning and the hazard symbol refers to procedure-specific risk. When these symbols appear in the body of this manual or on warning labels, refer back to these Warnings. Additional, product-specific warnings may be found throughout the body of this manual where applicable.

 WARNING	
	<p>FIRE AND EXPLOSION HAZARD</p> <p>Flammable fumes, such as solvent and paint fumes, in work area can ignite or explode. To help prevent fire and explosion:</p> <ul style="list-style-type: none"> • Use equipment only in well ventilated area. • Eliminate all ignition sources; such as pilot lights, cigarettes, portable electric lamps, and plastic drop cloths (potential static arc). • Keep work area free of debris, including solvent, rags and gasoline. • Do not plug or unplug power cords, or turn power or light switches on or off when flammable fumes are present. • Ground all equipment in the work area. See Grounding instructions. • Use only grounded hoses. • Hold gun firmly to side of grounded pail when triggering into pail. • If there is static sparking or you feel a shock, stop operation immediately. Do not use equipment until you identify and correct the problem. • Keep a working fire extinguisher in the work area.
	<p>PRESSURIZED EQUIPMENT HAZARD</p> <p>Fluid from the gun/dispense valve, leaks, or ruptured components can splash in the eyes or on skin and cause serious injury.</p> <ul style="list-style-type: none"> • Follow the Pressure Relief Procedure when you stop spraying and before cleaning, checking, or servicing equipment. • Tighten all fluid connections before operating the equipment. • Check hoses, tubes, and couplings daily. Replace worn or damaged parts immediately.

WARNING

 	<p>EQUIPMENT MISUSE HAZARD Misuse can cause death or serious injury.</p> <ul style="list-style-type: none"> • Do not operate the unit when fatigued or under the influence of drugs or alcohol. • Do not exceed the maximum working pressure or temperature rating of the lowest rated system component. See Technical Data in all equipment manuals. • Use fluids and solvents that are compatible with equipment wetted parts. See Technical Data in all equipment manuals. Read fluid and solvent manufacturer’s warnings. For complete information about your material, request MSDS from distributor or retailer. • Do not leave the work area while equipment is energized or under pressure. Turn off all equipment and follow the Pressure Relief Procedure when equipment is not in use. • Check equipment daily. Repair or replace worn or damaged parts immediately with genuine manufacturer’s replacement parts only. • Do not alter or modify equipment. • Use equipment only for its intended purpose. Call your distributor for information. • Route hoses and cables away from traffic areas, sharp edges, moving parts, and hot surfaces. • Do not kink or over bend hoses or use hoses to pull equipment. • Keep children and animals away from work area. • Comply with all applicable safety regulations.
 	<p>TOXIC FLUID OR FUMES HAZARD Toxic fluids or fumes can cause serious injury or death if splashed in the eyes or on skin, inhaled, or swallowed.</p> <ul style="list-style-type: none"> • Read MSDSs to know the specific hazards of the fluids you are using. • Route exhaust away from work area. If diaphragm ruptures, fluid may be exhausted into the air. • Store hazardous fluid in approved containers, and dispose of it according to applicable guidelines.
	<p>BURN HAZARD Equipment surfaces and fluid that’s heated can become very hot during operation. To avoid severe burns:</p> <ul style="list-style-type: none"> • Do not touch hot fluid or equipment.
  	<p>PERSONAL PROTECTIVE EQUIPMENT You must wear appropriate protective equipment when operating, servicing, or when in the operating area of the equipment to help protect you from serious injury, including eye injury, hearing loss, inhalation of toxic fumes, and burns. This equipment includes but is not limited to:</p> <ul style="list-style-type: none"> • Protective eyewear, and hearing protection. • Respirators, protective clothing, and gloves as recommended by the fluid and solvent manufacturer.

Installation

General Information

- VA-H25 SA, VA-H40 SA, and VA-H50 SA pumps have painted aluminum center sections that may exhibit signs of corrosion depending on cleaning solutions used.
- The typical installation shown in FIG. 2 is only a guide for selecting and installing system components. Contact your Verder representative for assistance in planning a system to suit your needs.
- Reference numbers and letters in parentheses refer to the callouts in the figures and the parts lists on pages 26-28, 32-34, and 38-40.

<p>The pump is heavy (see Technical Data on pages 30, 36, and 42 for specific weights). If dropped, the pump may rupture. To avoid serious injury, including from splashing fluid, follow the Pressure Relief Procedure on page 12. Have two people to lift the pump by grasping the outlet manifold securely or use appropriate lifting equipment.</p>						

<p>To reduce the risk of serious injury due to burns, insulate and/or label the pump before pumping hot fluids.</p>						

Tighten Clamps Before First Use

After you unpack the pump, and before you use it for the first time, check all clamps and tighten as necessary.

Grounding

<p>The equipment must be grounded to reduce the risk of static sparking. Static sparking can cause fumes to ignite or explode. Grounding provides an escape wire for the electric current.</p>						

- *Pump:* Connect a ground wire and clamp as shown in Fig. 1. Loosen the grounding screw (W). Insert one end of a 12 ga (1.5 mm²) minimum ground wire (Y) behind the grounding screw and tighten the screw securely. Connect the clamp end of the ground wire to a true earth ground. Order ground wire Part Number 819.0673.

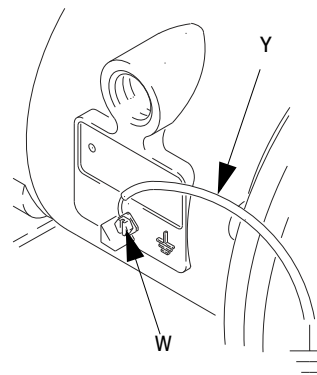

FIG. 1

- *Fluid hoses:* Use only grounded hoses with a maximum of 150 m (500 ft.) combined hose length to ensure grounding continuity.
- *Air compressor:* Follow the manufacturer's recommendations.
- *All solvent pails used when flushing:* Follow the local code. Use only metal pails, which are conductive. Do not place the pail on a non-conductive surface, such as paper or cardboard, which interrupts the grounding continuity.
- *Fluid supply container:* Follow the local code.

Mountings





NOTICE

The pump exhaust air may contain contaminants that can contaminate the fluid supply. Ventilate to a remote area. See **Air Exhaust Ventilation** on page 11.

- Be sure the mounting surface can support the weight of the pump, hoses, and accessories, as well as the stress caused during operation.
- For all mountings, be sure the pump is bolted directly to the mounting surface.
- For ease of operation and service, mount the pump so the air valve cover, air inlet, and fluid inlet and outlet ports are easily accessible.

Air Line

1. Install the air line accessories as shown in FIG. 2. Mount these accessories on the wall or on a bracket. Be sure the air line supplying the accessories is grounded.
 - a. Install an air regulator (C) and gauge to control the fluid pressure. The fluid outlet pressure will be the same as the setting of the air regulator. The air line filter removes harmful dirt and moisture from the compressed air supply.
 - b. Locate one bleed-type master air valve (B) close to the pump and use it to relieve trapped air. Be sure the valve is easily accessible from the pump and located downstream from the regulator.

						
<p>Trapped air can cause the pump to cycle unexpectedly, which could result in serious injury, including splashing in the eyes or on the skin, injury from moving parts, or contamination from hazardous fluids.</p>						

- c. Locate the other master air valve (E) upstream from all air line accessories and use it to isolate them during cleaning and repair.







In the step below, do not connect the quick-disconnect coupler (D) on the air hose to the mating fitting on the pump until you are ready to operate the pump. Connecting the coupler too early can result in unintentional operation of the pump, leading to serious injury from moving parts, splashing fluid in the eyes or on the skin, and contact with hazardous fluids.

2. Install a grounded, flexible air hose (A) between the accessories and the 1/2 npt(f) pump air inlet (N). See Fig. 5. Use a minimum 9.5 mm (3/8 in.) ID air hose. Screw an air line quick disconnect coupler (D) onto the end of the air hose (A), and screw the mating fitting into the pump air inlet snugly.

Fluid Suction Line

1. Use flexible, grounded fluid hoses.
2. For best sealing results, use an appropriate tri-clamp-style or DIN-style sanitary gasket of a flexible material such as EPDM, Buna-N, fluoroelastomer, or silicon.
3. If the fluid inlet pressure to the pump is more than 25% of the outlet working pressure, the ball check valves will not close fast enough, resulting in inefficient pump operation.
4. At inlet fluid pressures greater than 1 bar (0.1 MPa, 15 psi), diaphragm life will be shortened.
5. See the **Technical Data** on pages 30, 36, and 42 for maximum suction lift (wet and dry). For best results, always install the pump as close as possible to the material source.

Fluid Outlet Line

						
<p>A fluid drain valve (J) is required to relieve pressure in the hose if it is plugged. The drain valve reduces the risk of serious injury, including splashing in the eyes or on the skin, or contamination from hazardous fluids when relieving pressure.</p>						

1. Use flexible grounded fluid hoses (L).
2. For best sealing results, use an appropriate tri-clamp-style or DIN-style sanitary gasket of a flexible material such as EPDM, Buna-N, fluoroelastomer, or silicon.
3. Install a fluid drain valve (J) near the fluid outlet. See the **WARNING** above, and FIG. 2.
4. Install a shutoff valve (K) in the fluid outlet line.

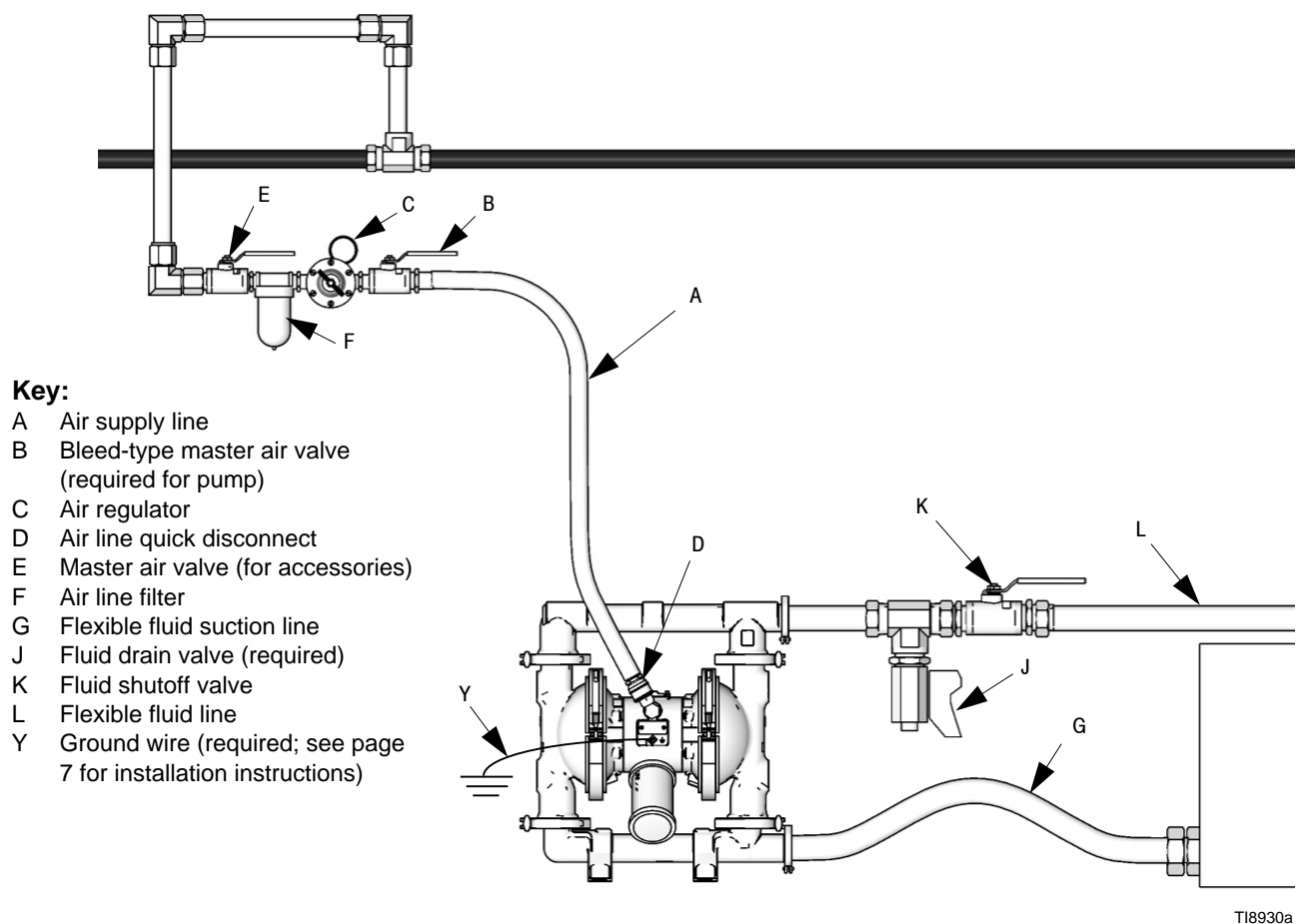

FIG. 2 Typical Floor-Mount Installation

Changing the Orientation of the Fluid Inlet and Outlet Ports

The pump is shipped with the ports facing the same direction. To reverse the orientation of the ports:

1. Remove the clamps holding the inlet and/or outlet manifold to the covers.

NOTE: Inspect the o-rings and replace if necessary.

2. Reverse the manifold and reattach. Install and tighten clamps snugly.

Key:

- N 1/2 npt(f) air inlet port
- P Muffler (air exhaust port is 3/4 npt(f))
- R Fluid inlet port
- S Fluid outlet port
- 113 Manifold clamps
- 3 Air valve screws

 Torque to
3.2-3.7 N•m
(28-30 in-lb)

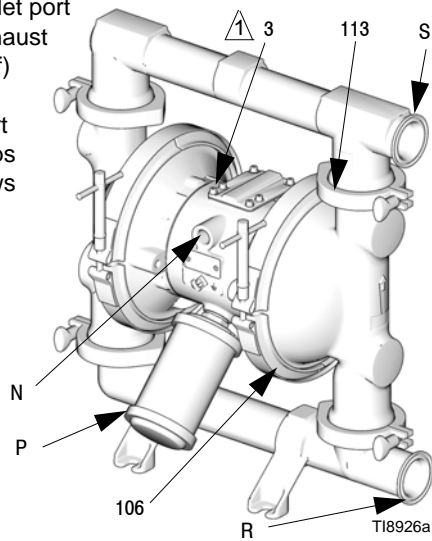





FIG. 3. Reverse the Manifolds

Air Exhaust Ventilation

						
<p>To avoid serious injury from explosion or hazardous fluids:</p> <ul style="list-style-type: none"> • be sure the system is properly ventilated for your type of installation. • vent the exhaust away from people, animals, food handling areas, and all sources of ignition. • place an appropriate container at the end of the air exhaust line to catch fluid. If a diaphragm ruptures, the fluid being pumped will exhaust with the air. See FIG. 4. 						

NOTICE

The air exhaust port is 3/4 npt(f). Do not restrict the air exhaust port. Excessive exhaust restriction can cause erratic pump operation.

To provide a remote exhaust:

1. Remove the muffler (P) from the pump air exhaust port.
2. Install a grounded air exhaust hose (T) and connect the muffler (P) to the other end of the hose. The minimum size for the air exhaust hose is 19 mm (3/4 in.) ID. If a hose longer than 4.57 m (15 ft.) is required, use a larger diameter hose. Avoid sharp bends or kinks in the hose.
3. Place a container (U) at the end of the air exhaust line to catch fluid in case a diaphragm ruptures. See FIG. 4.

Key:

- A Air supply line
- B Bleed-type master air valve (required for pump)
- C Air regulator
- D Air line quick disconnect
- E Master air valve (for accessories)
- F Air line filter
- P Muffler
- T Grounded air exhaust hose
- U Container for remote air exhaust

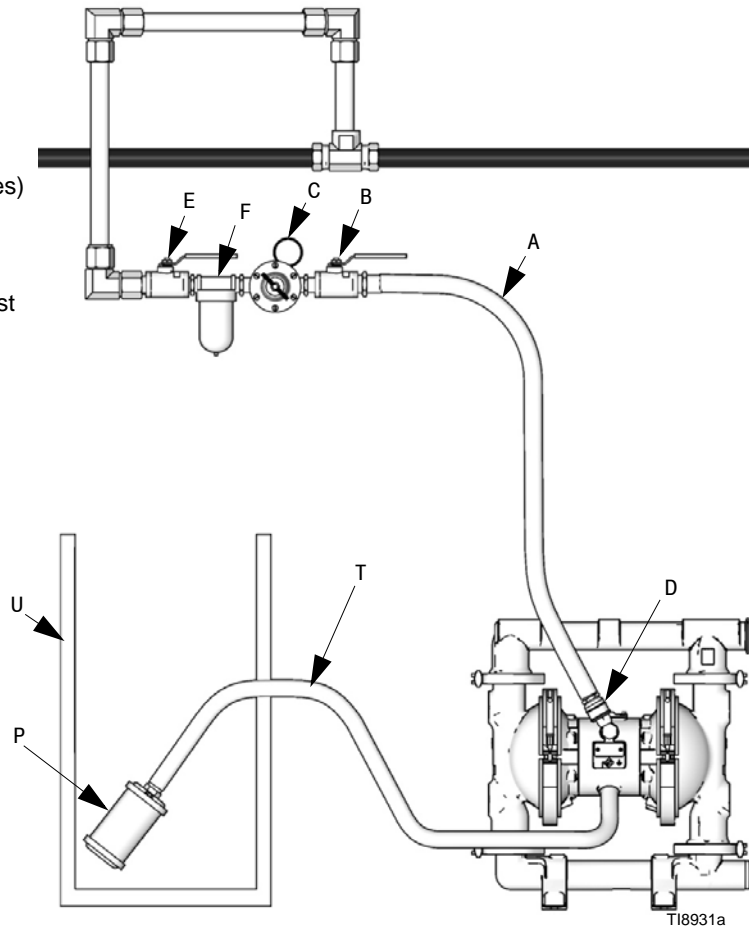







FIG. 4 Venting Exhaust Air

Operation

Pressure Relief Procedure



 Follow the Pressure Relief Procedure whenever you see this symbol.

						
<p>The equipment stays pressurized until pressure is manually relieved. To reduce the risk of serious injury from pressurized fluid or splashing fluid, follow this procedure whenever you stop pumping and before cleaning, checking, or servicing equipment.</p>						

1. Shut off the air to the pump.
2. Open the dispensing valve, if used.
3. Open the fluid drain valve to relieve fluid pressure, having a container ready to catch the drainage.

Sanitize the Pump Before First Use

It is the user's responsibility to properly sanitize the pump before first use. As necessary, follow the steps under **Starting and Adjusting the Pump** on this page, under the **Service** section on page 16, or under **Flushing** on page 13.

						
<p>To avoid serious injury from splashing fluid, never move or lift a pump under pressure. If dropped, the fluid section may rupture. Always follow the Pressure Relief Procedure before lifting the pump.</p>						

Starting and Adjusting the Pump

1. Be sure the pump is properly grounded. Refer to **Grounding** on page 7.
2. Check connections to be sure they are tight. Tighten fluid inlet and outlet connections securely.
3. Place the suction tube (if used) in fluid to be pumped.

NOTE: If fluid inlet pressure to the pump is more than 25% of outlet working pressure, the ball check valves will not close fast enough, resulting in inefficient pump operation.

4. Place the end of fluid hose (L) into an appropriate container.
5. Close the fluid drain valve (J).
6. Back out the air regulator (C) knob, and open all bleed-type master air valves (B, E).
7. If the fluid hose has a dispensing device, hold it open while continuing with the following step.
8. Slowly increase air pressure with the air regulator (C) until the pump starts to cycle. Allow the pump to cycle slowly until all air is pushed out of the lines and the pump is primed.

Pump Shutdown

						
---	---	--	--	--	--	--

At the end of the work shift, relieve pressure.

Maintenance

Air Valve Lubrication

The air valve is designed to operate unlubricated. If lubrication is desired, however, every 500 hours of operation (or monthly) remove the hose from the pump air inlet and add two drops of machine oil to the air inlet.

NOTICE

Do not over-lubricate the pump. Oil is exhausted through the muffler and could contaminate your fluid supply or other equipment. Excessive lubrication can also cause the pump to malfunction.

Flushing



Insert suction tube into cleaning solution. Open air regulator to supply low pressure air to the pump. Run the pump long enough to thoroughly clean the pump and hoses. Close the air regulator. Remove the suction tube from the cleaning solution and drain pump. Place suction tube in the fluid to be pumped.

Flush the pump often enough to prevent the fluid you are pumping from drying or freezing in the pump and damaging it. Flushing schedule will be based on what the pump is being used for. Use a compatible cleaning solution and always cycle the pump during the entire flushing process.

Always flush the pump and relieve the pressure before storing it for any length of time.

Tightening Connections

Before each use, check all hoses for wear or damage, and replace as necessary. Check to be sure all connections are tight and leak-free.

Preventive Maintenance Schedule

Establish a preventive maintenance schedule, based on the pump's service history. This is especially important for prevention of spills, leakage, or food contamination due to diaphragm failure. Inspect all diaphragms for damage at every cleaning.

Troubleshooting

						
<p>To reduce the risk of serious injury, whenever you are instructed to relieve pressure, always follow the Pressure Relief Procedure on page 12.</p>						

- Relieve the pressure before checking or servicing the equipment.
- Check all possible problems and causes before disassembling the pump.

PROBLEM	CAUSE	SOLUTION
Pump cycles at stall or fails to hold pressure at stall.	Worn check valve balls (301), seats (201) or o-rings (202).	Replace. See 18.
Pump will not cycle, or cycles once and stops.	Air valve is stuck or dirty.	Disassemble and clean air valve. See page 16. Use filtered air.
	Check valve ball (301) severely worn and wedged in seat (201) or manifold (102 or 103).	Replace ball and seat. See page 18.
	Dispensing valve clogged.	Relieve pressure and clear valve.
Pump operates erratically.	Clogged suction line.	Inspect; clear.
	Sticky or leaking balls (301).	Clean or replace. See page 18.
	Diaphragm ruptured.	Replace. See page 19 (standard diaphragms) or page 22 (overmolded diaphragms).
	Restricted exhaust.	Remove restriction.
Air bubbles in fluid.	Suction line is loose.	Tighten.
	Diaphragm ruptured.	Replace. See page 19 (standard diaphragms) or page 22 (overmolded diaphragms).
	Loose inlet manifold (102), damaged seal between manifold and seat (201), damaged o-rings (202).	Tighten manifold clamps (113), or replace seats (201) or o-rings (202). See page 18.
	Loose diaphragm shaft bolt (107).	Tighten or replace (pages 19-21).
	Damaged o-ring (108).	Replace. See pages 19-21.
Chattering - noisy operation.	Check valve balls do not seat properly/cleanly due to imbalance between fluid inlet and outlet line sizing. Noise is accentuated with light viscosity fluids.	Reduce size/diameter of inlet line relative to outlet line. Outlet line size should not exceed pump size.

PROBLEM	CAUSE	SOLUTION
Leak in inlet or outlet sanitary fitting.	Loose sanitary clamp.	Tighten clamp.
	Damaged or worn gasket.	Replace gasket.
	Misalignment of inlet/outlet hose or pipe.	Use flexible hoses at pump inlet and outlet.
	Gasket does not seal.	Use a standard sanitary gasket of flexible material such as EPDM, Buna-N, fluoroelastomer, or silicon.
Fluid in exhaust air.	Diaphragm ruptured.	Replace. See page 19 (standard diaphragms) or page 22 (overmolded diaphragms).
	Loose diaphragm shaft bolt (107).	Tighten or replace. See pages 19-21.
	Damaged o-ring (108).	Replace. See pages 19-21.
Pump exhausts excessive air at stall.	Worn air valve block (7), o-ring (6), plate (8), pilot block (18), u-cups (402), or pilot pin o-rings (17).	Repair or replace. See page 16.
	Worn shaft seals (402).	Replace. See page 19 (standard diaphragms) or page 22 (overmolded diaphragms).
Pump leaks air externally.	Air valve cover (2) or air valve cover screws (3) are loose.	Tighten screws. See page 16.
	Air valve gasket (4) or air cover gasket (22) is damaged.	Inspect; replace. See pages 16 and 24.
	Air cover screws (25) are loose.	Tighten screws. See page 16.
Pump leaks fluid externally from ball check valves.	Loose manifolds (102, 103), damaged seal between manifold and seat (201), damaged o-rings (202).	Tighten manifold clamps (113), or replace seats (201) or o-rings (202). See page 18.

Service

Repairing the Air Valve

Tool Required

- Torque wrench
- Torx (T20) screwdriver or 7 mm (9/32 in.) socket wrench
- Needle-nose pliers
- O-ring pick
- Lithium base grease

NOTE: Air Valve Repair Kits are available. Order Kit 819.0667 for models with stainless steel center housing. Order Kit 819.0666 for models with aluminum center housing. Parts included in Kit 819.0667 are marked with †, and parts included in Kit 819.0666 are marked with ◆. Use all the parts in the kit for the best results.

Disassembly



1. Follow the **Pressure Relief Procedure**, page 12.
2. With a Torx (T20) screwdriver or 7 mm (9/32 in.) socket wrench, remove the six screws (3), air valve cover (2), and gasket (4). See FIG. 5.
3. Move the valve carriage (5) to the center position and pull it out of the cavity. Remove the valve block (7) and o-ring (6) from the carriage. Using a needle-nose pliers, pull the pilot block (18) straight up and out of the cavity. See FIG. 6.
4. Pull the two actuator pistons (11) out of the bearings (12). Remove the u-cup packings (402) from the pistons. Pull the pilot pins (16) out of the bearings (15). Remove the o-rings (17) from the pilot pins. See FIG. 7.
5. Inspect the valve plate (8) in place. If damaged, use a Torx (T20) screwdriver or 7 mm (9/32 in.) socket wrench to remove the three screws (3). Remove the valve plate (8). See FIG. 8.
6. Inspect the bearings (12, 15) in place. See FIG. 7. The bearings are tapered and, if damaged, must be removed from the outside. This requires disassembly of the fluid section. See page 24.
7. Clean all parts and inspect for wear or damage. Replace as needed. Reassemble.

Reassembly

NOTE: Apply lithium-based grease whenever instructed to grease. Order part number 819.0184.

1. *If you replaced the bearings (12, 15),* reinstall as explained on page 24. Reassemble the fluid section.
2. On models with aluminum center housing, install the valve plate seal (55◆) into the groove at the bottom of the valve cavity. The rounded side of the seal **must face down** into the groove. See FIG. 8.
3. Install the valve plate (8†) in the cavity, seal down. Install the three screws (3), using a Torx (T20) screwdriver or 7 mm (9/32 in.) socket wrench. Tighten until the screws bottom out on the housing. See FIG. 8.
4. Install an o-ring (17†◆) on each pilot pin (16). Grease the pins and o-rings. Insert the pins into the bearings (15), **narrow** end first. See FIG. 7.
5. Install a u-cup packing (10†◆) on each actuator piston (11), so the lips of the packings face the **narrow** end of the pistons. See FIG. 7.
6. Lubricate the u-cup packings (10†◆) and actuator pistons (11). Insert the actuator pistons in the bearings (12), **wide** end first. Leave the narrow end of the pistons exposed. See FIG. 7.
7. Grease the lower face of the pilot block (18†◆) and install so its tabs snap into the grooves on the ends of the pilot pins (16). See FIG. 6.
8. Grease the o-ring (6†◆) and install it in the valve block (7†◆). Push the block onto the valve carriage (5). Grease the lower face of the valve block. See FIG. 6.
9. Install the valve carriage (5) so its tabs slip into the grooves on the narrow end of the actuator pistons (11). See FIG. 6.
10. Align the valve gasket (4†◆) and cover (2) with the six holes in the center housing (1). Secure with six screws (3), using a Torx (T20) screwdriver or 7 mm (9/32 in.) socket wrench. Torque to 5.6-6.8 N•m (52-60 in-lb). See FIG. 5.

⚠ Torque to 5.6-6.8 N•m (52-60 in-lb).

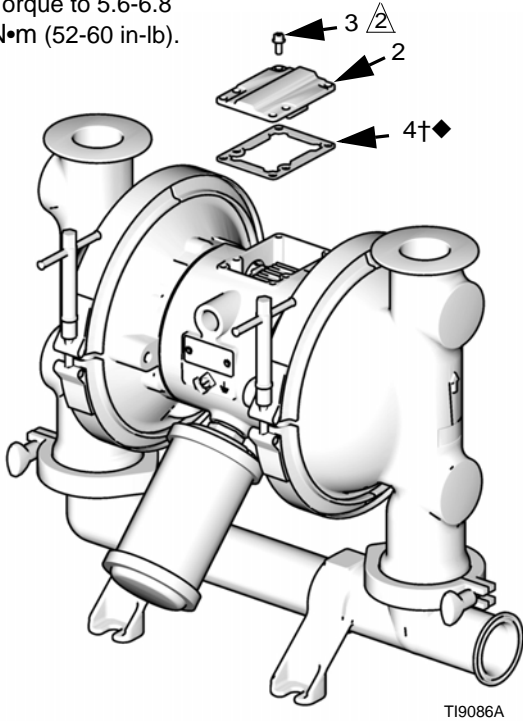

T19086A

FIG. 5

⚠ Insert narrow end first.

⚠ Grease.

⚠ Install with lips facing narrow end of piston (11).

⚠ Insert wide end first.

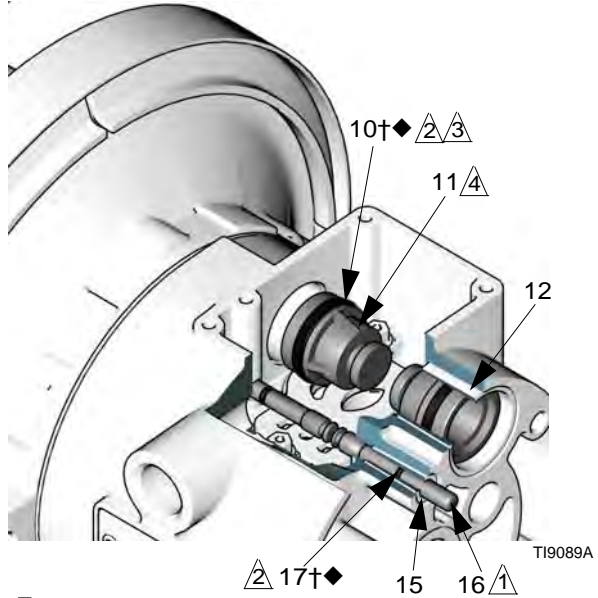

T19089A

FIG. 7

⚠ See detail at right.

⚠ Grease.

⚠ Grease lower face.

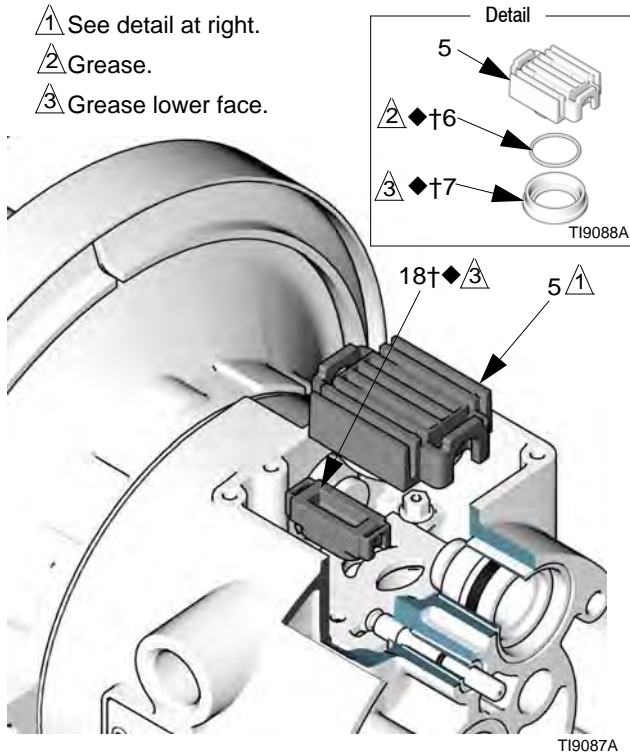

T19087A

FIG. 6

⚠ Tighten screws until they bottom out on the housing.

⚠ Rounded side of seal must face down. (Seal is used only on models with aluminum center housing).

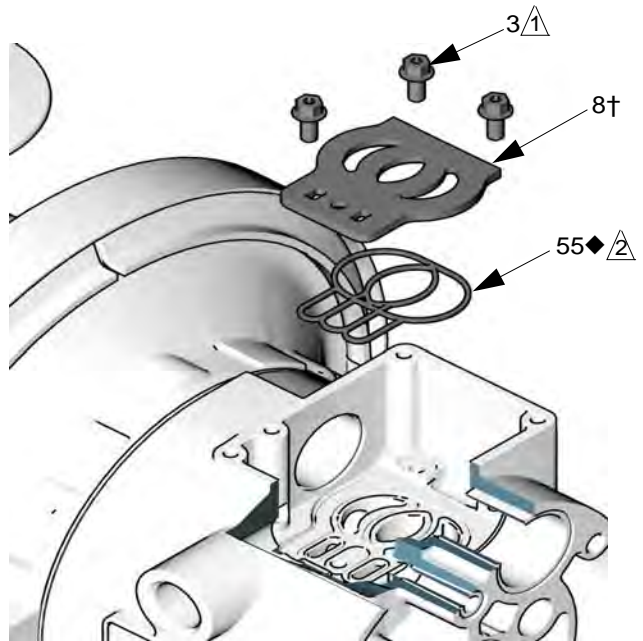

T19090A

FIG. 8

Ball Check Valve Repair

Tools Required

- O-ring pick

Disassembly

NOTE:

- A Fluid Section Repair Kit is available. Refer to the parts section for the appropriate pump size so that the correct kit for your pump is ordered. Parts included in the kit are marked with an asterisk, for example (202*). Use all the parts in the kit for the best results.
- To ensure proper seating of the balls (301), always inspect the seats (201) when replacing the balls. Replace seats as necessary if seating surface shows evidence of wear. Also, replace the o-rings (202) as necessary. PTFE o-rings should be replaced every time manifolds are removed.



1. Follow the **Pressure Relief Procedure**, page 12. Disconnect all hoses.
2. Remove the pump from its mounting.
3. Remove the clamps (106) holding the outlet manifold (103) to the fluid covers (101). See FIG. 9.
4. Remove the o-rings (202), seats (201), and balls (301) from the manifold (103).
5. Turn the pump over and remove the inlet manifold (102). Remove the o-rings (202), seats (201), and balls (301) from the fluid covers (101).

Reassembly

1. Clean all parts and inspect for wear or damage. Replace parts as needed.
2. Reassemble in the reverse order, following all notes in FIG. 9. Be sure the ball checks and manifolds are assembled **exactly** as shown. The arrows (A) on the fluid covers (101) **must** point toward the outlet manifold (103).

- △1 Arrow (A) must point toward outlet manifold (103)
- △2 Radiused seating surface must face the ball (301). Large chamfer on O.D. must face o-ring.

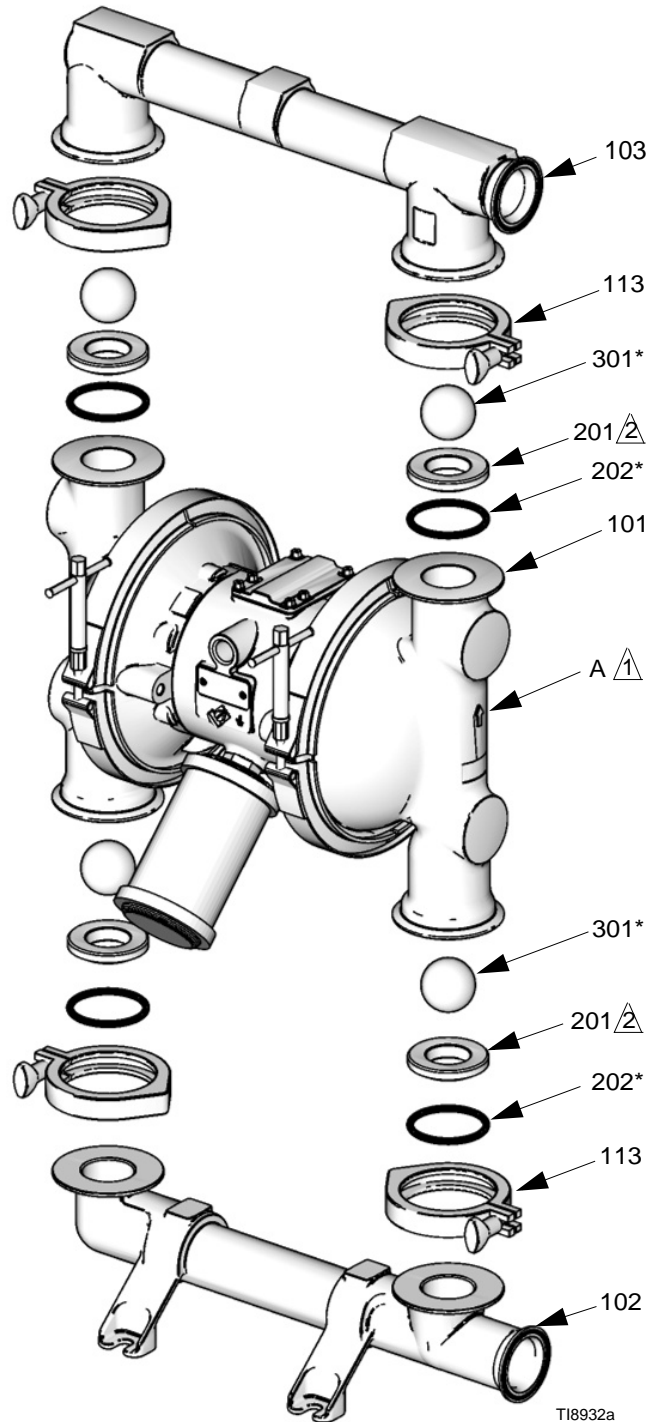

FIG. 9

Standard Diaphragm Repair

NOTE: If your pump uses overmolded diaphragms, see page 22.

Tools Required

- Torque wrench
- 15 mm socket wrench
- 19 mm open end wrench
- O-ring pick
- Lithium-base grease

Disassembly

NOTE: A Fluid Section Repair Kit is available. Refer to page 28, 34, or 40 to order the correct kit for your pump. Parts included in the kit are marked with an asterisk, for example (401*). Use all the parts in the kit for the best results.



1. Follow the **Pressure Relief Procedure**, page 12.
2. Remove the manifolds and disassemble the ball check valves as explained on page 18.
3. Remove the clamps (106) holding the fluid covers (101) to the air covers (23). Pull the fluid covers (101) off the pump. See FIG. 10.

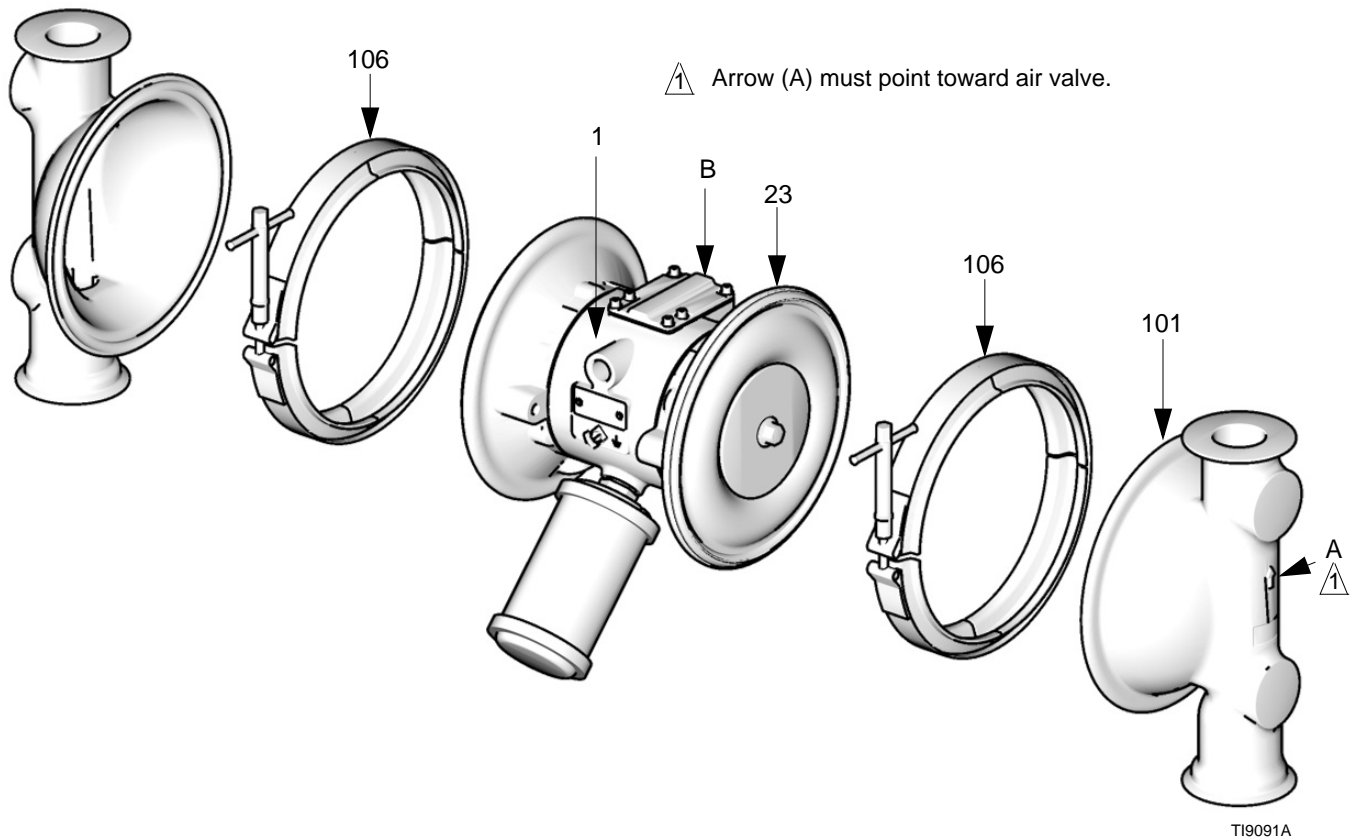

FIG. 10

4. Loosen but do not remove the diaphragm shaft bolts (107), using a 15 mm socket wrench on both bolts. See FIG. 11.
5. Unscrew one bolt from the diaphragm shaft (24) and remove the o-ring (108), fluid side diaphragm plate (105), diaphragm (403), backer (401) used only on PTFE models, and air side diaphragm plate (104). See FIG. 11.
6. Pull the other diaphragm assembly and the diaphragm shaft (24) out of the center housing (1). Hold the shaft flats with a 19 mm open end wrench, and remove the bolt (107) from the shaft. Disassemble the remaining diaphragm assembly.
7. Inspect the diaphragm shaft (24) for wear or scratches. If it is damaged, inspect the bearings (19) in place. If the bearings are damaged, refer to page 24.
8. Reach into the center housing (1) with an o-ring pick and hook the u-cup packings (402), then pull them out of the housing. This can be done with the bearings (19) in place.
9. Clean all parts and inspect for wear or damage. Replace parts as needed.
- d. On PTFE models only, install the backer (401*) on the bolt. Make certain the side marked AIR SIDE faces the center housing (1).
- e. Install the air side diaphragm plate (104) so the rounded side faces the diaphragm (401). This plate is stamped with its part number.
- f. Apply medium-strength (blue) thread locker to the bolt (107) threads. Screw the bolt into the shaft (24) hand tight.
3. Grease the length and ends of the diaphragm shaft (24), and slide it through the housing (1).
4. Assemble the other diaphragm assembly to the shaft as explained in step 2.
5. Hold one shaft bolt (107) with a wrench and torque the other bolt to 81-95 N•m (60-70 ft-lb) at 100 rpm maximum.
6. Align the fluid covers (101) and the center housing (1) so the arrows (A) on the covers face the same direction as the air valve (B). Secure covers with the clamps. See FIG. 10.
7. Reassemble the ball check valves and manifolds as explained on page 18.

Reassembly

NOTE: Apply lithium-based grease whenever instructed to grease. Order part number 819.0184.

1. Install the shaft u-cup packings (402*) so the lips face **out** of the housing (1). Lubricate the packings. See FIG. 11.
2. Install the diaphragm assembly on one end of the shaft (24) as follows:
 - a. Install the o-ring (108*) on the shaft bolt (107).
 - b. Install the fluid side diaphragm plate (105) on the bolt so the rounded side faces the diaphragm (401).

NOTE: The fluid side diaphragm plate (105) is stainless steel. This plate **is not** stamped with its part number. Be sure to install this plate on the fluid side of the diaphragm.

- c. Install the diaphragm (403*). Make certain the side marked AIR SIDE faces the center housing (1).

Cutaway view, with diaphragms in place

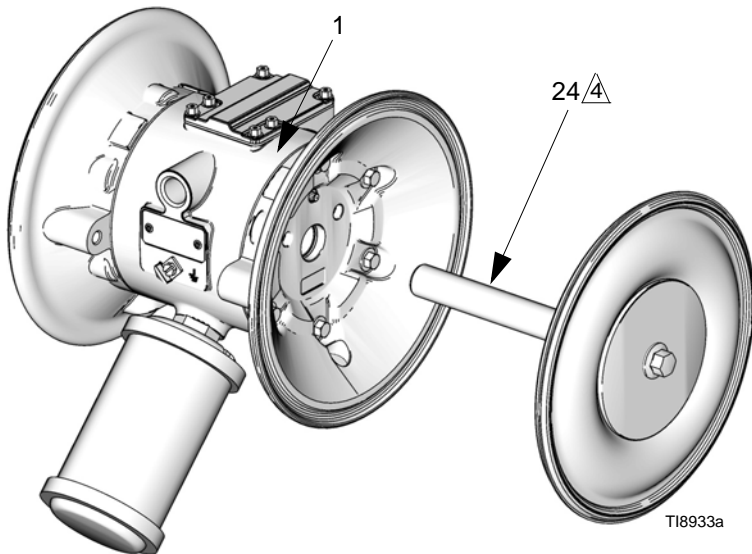
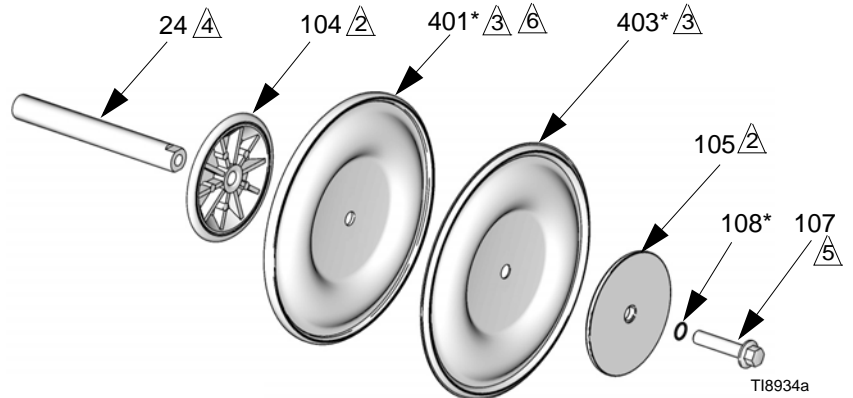
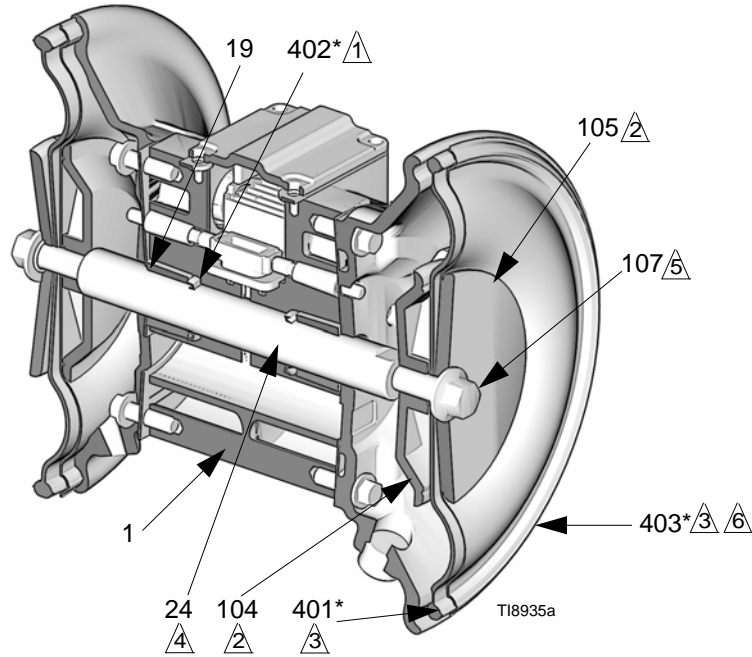

- ⚠️ Lips face out of housing (1).
- ⚠️ Rounded side faces diaphragm (401).
- ⚠️ Air side must face center housing (1).
- ⚠️ Grease.
- ⚠️ Apply medium strength (blue) thread locker. Torque to 81-95 N•m (60-70 ft-lb) at 100 rpm maximum.
- ⚠️ Backer used on pumps with PTFE diaphragms only.

FIG. 11

Overmolded Diaphragm Repair

NOTE: If your pump uses standard diaphragms, see page 19.

Tools Required

- Torque wrench
- 19 mm open end wrench
- O-ring pick
- Lithium-based grease

Disassembly

NOTE: A Fluid Section Repair Kit is available. Refer to page 28, 34, or 40 to order the correct kit for your pump. Parts included in the kit are marked with an asterisk, for example (401*). Use all the parts in the kit for the best results.



1. Follow the **Pressure Relief Procedure**, page 12.
2. Remove the manifolds and disassemble the ball check valves as explained on page 18.
3. Remove the clamps (106) holding the fluid covers (101) to the air covers (23). Pull the fluid covers (101) off the pump. See FIG. 12.
4. Once the fluid covers are removed, the diaphragm on the side of the pump which was last pressurized with air will be separated from the center section/air cover. This allows you to grip the diaphragms.
5. Diaphragms are assembled handtight. To loosen, grip both diaphragms securely around the outer edge and rotate counterclockwise. One diaphragm assembly will come free and the other will remain attached to the shaft. Remove the freed diaphragm (403) and air side plate (104).
6. Pull the opposite diaphragm assembly and shaft (24) out of the center housing (1). Hold the shaft flats with a 19 mm open end wrench and remove the diaphragm and air side plate from the shaft.
7. Inspect the diaphragm shaft (24) for wear or scratches. If it is damaged, inspect the bearings (19) in place. If the bearings are damaged, refer to page 24.

8. Reach into the center housing (1) with an o-ring pick and hook the u-cup packings (402), then pull them out of the housing. This can be done with the bearings (19) in place.
9. Clean all parts and inspect for wear or damage. Replace parts as needed.

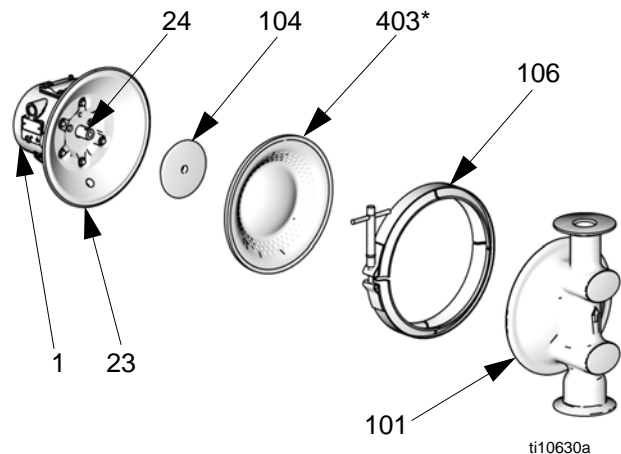



FIG. 12

Reassembly

NOTE: Apply lithium-based grease whenever instructed to grease. Order part number 819.0184.

						
To reduce the risk of serious injury, including amputation, do not put your fingers or hand between the air cover and the diaphragm.						

1. Install the shaft u-cup packings (402*) so the lips face **out** of the housing (1). Lubricate the packings. See FIG. 13.
2. Assemble the air side plate (104) onto the diaphragm (403). The wide, radiused side of the plate must face the diaphragm. Apply medium-strength (blue) thread locker to the threads of the diaphragm assembly. Screw the assembly into the shaft (24) hand tight.
3. Grease the length and ends of the diaphragm shaft (24). Insert the shaft/diaphragm assembly into one side of the pump. Assemble the fluid cover (101) and clamp (106) so the arrow (A) on the cover faces the same direction as the air valve (B). Securely tighten the clamp.
4. Assemble the other diaphragm assembly to the shaft as explained in step 2. This diaphragm will be lifted off the air cover at this point.
5. Supply the pump with low pressure air (less than 0.5 bar [.05 MPa, 7 psi]). The diaphragm will very slowly pull onto the air cover (23). Find the pressure that keeps the diaphragm close enough to clamp, but does not let it contact the pilot pin.

NOTICE

Do not deform the diaphragm manually. The diaphragm needs uniform pressure to deform properly for maximum life.

6. Assemble the fluid cover (101) and clamp (106) so the arrow (A) on the cover faces the same direction as the air valve (B). Securely tighten the clamp.

NOTE: If the diaphragm contacts the pilot pin and is forced away from the air cover, try Step 5 again. If necessary, return to Step 3.

7. Reassemble the ball check valves and manifolds as explained on page 18.

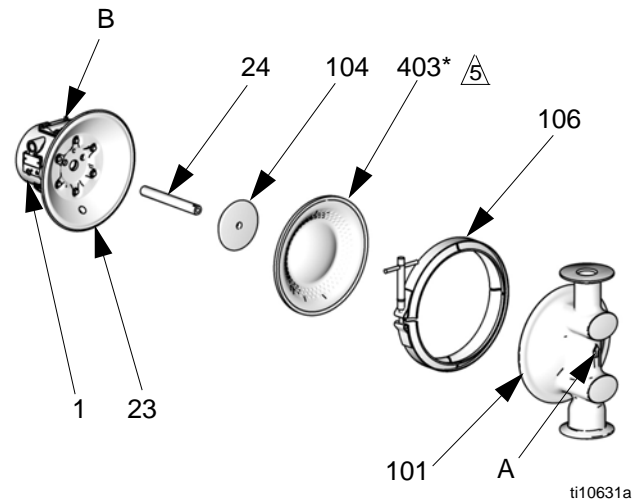

 Apply medium strength (blue) thread locker to bolt (not shown).

FIG. 13

Bearing and Air Gasket Removal

Tools Required

- Torque wrench
- 10 mm socket wrench
- Bearing puller
- O-ring pick
- Press, or block and mallet

Disassembly

NOTE: Do not remove undamaged bearings.



1. Follow the **Pressure Relief Procedure**, page 12.
2. Remove the manifolds and disassemble the ball check valves as explained on page 18.
3. Remove the fluid covers and diaphragm assemblies as explained on page 19.

NOTE: If you are removing only the diaphragm shaft bearings (19), skip step 4.

4. Disassemble the air valve as explained on page 16.
5. Using a 10 mm socket wrench, remove the screws (25) holding the air covers (23) to the center housing (1). See FIG. 14.
6. Remove the air cover gaskets (22). Always replace the gaskets with new ones.
7. Use a bearing puller to remove the diaphragm shaft bearings (19), air valve bearings (12) or pilot pin bearings (15). Do not remove undamaged bearings.
8. If you removed the diaphragm shaft bearings (19) reach into the center housing (1) with an o-ring pick and hook the u-cup packings (402), then pull them out of the housing. Inspect the packings. See FIG. 11, page 21.

Reassembly

1. If removed, install the shaft u-cup packings (402*) so the lips face **out** of the housing (1). See FIG. 11.
2. The bearings (12, 15, and 19) are tapered and can only be installed one way. Insert the bearings into the center housing (1), **tapered end first**. Using a press or a block and rubber mallet, press-fit the

bearing so it is flush with the surface of the center housing.

3. Reassemble the air valve as explained on page 16.
4. Align the new air cover gasket (22) so the pilot pin (16) protruding from the center housing (1) fits through the proper hole (H) in the gasket.
5. Align the air cover (23) so the pilot pin (16) fits in the middle hole (M) of the three small holes near the center of the cover. Install the screws (25), hand-tight. Apply medium-strength (blue) thread locker to the threads of the screws (25). See FIG. 14. Using a 10 mm socket wrench, torque the screws oppositely and evenly to 15-17 N•m (130-150 in-lb).
6. Install the diaphragm assemblies and fluid covers as explained on page 19.
7. Reassemble the ball check valves and manifolds as explained on page 18.

- 1 Insert bearings tapered end first.
- 2 Press-fit bearings flush with surface of center housing (1).
- 3 Apply medium strength (blue) Loctite® or equivalent. Torque to 15-17 N•m (130-150 in-lb).

Detail of air valve bearings

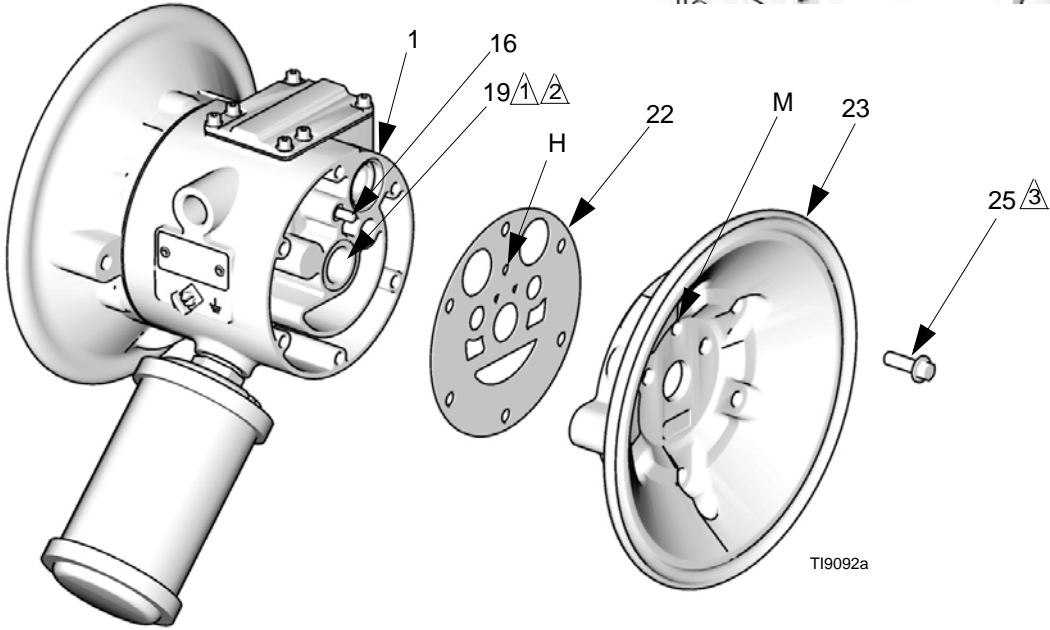
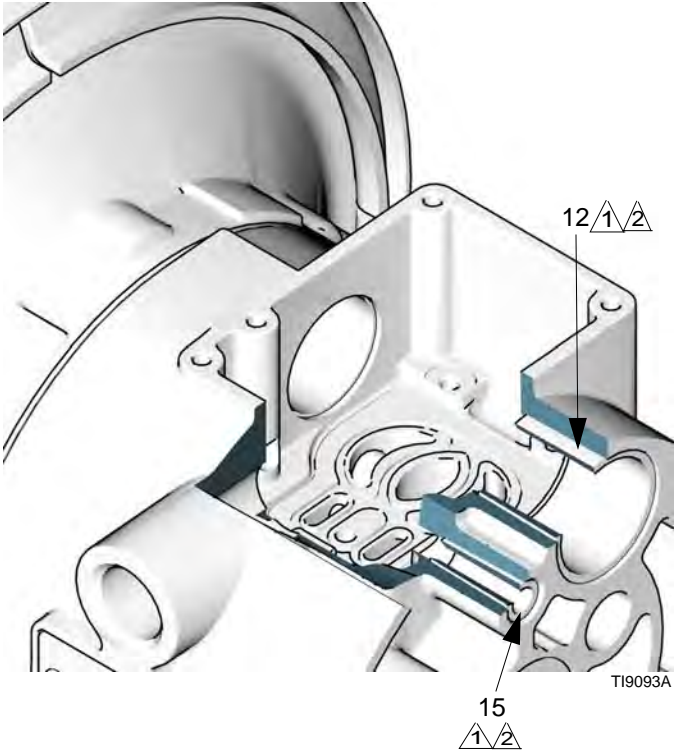
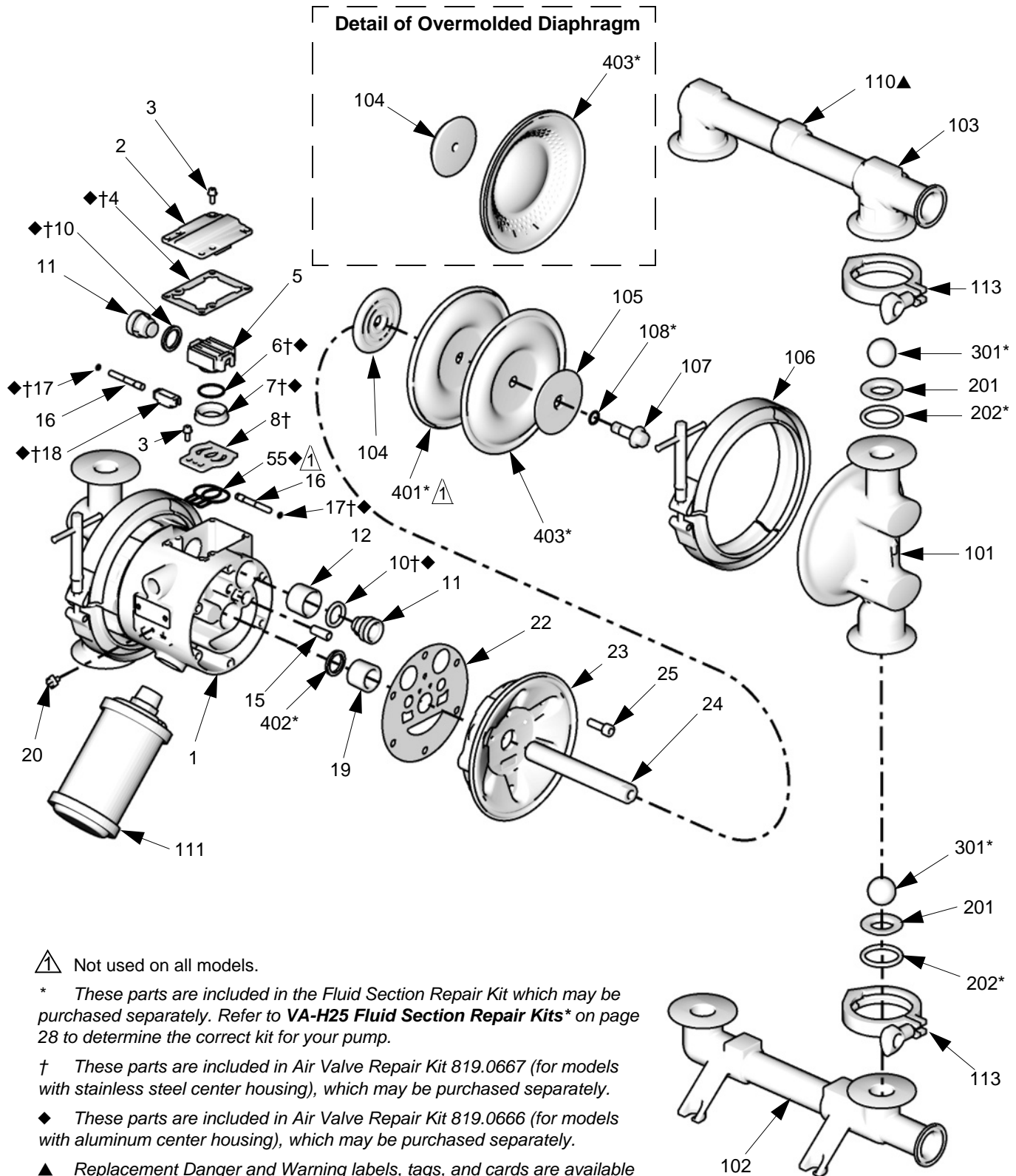

FIG. 14

Parts, VA-H25 Models



T110634a

Parts, VA-H25 Models, *continued*

Air Motor

Digit	Ref.	Part No.	Description	Qty
SS	1	819.0247	HOUSING, center; SST	1
	2	819.0259	COVER, air valve; SST	1
	8†	819.0248	PLATE, air valve; SST	1
SA	1	819.4275	HOUSING, center, aluminum	1
	2	819.4276	COVER, air valve; aluminum	1
	8	819.4282	PLATE, air valve, aluminum	1
	55◆	819.4274	SEAL, valve plate	1

Air Motor Common Parts

Ref.	Part No.	Description	Qty
3	819.0221	SCREW, mach, hex flange hd; M5 x 0.8; 12 mm (0.47 in.)	9
4†◆	819.4278	GASKET, cover	1
5	819.4279	CARRIAGE; aluminum	1
6†◆	819.4280	O-RING; nitrile	1
7†◆	819.4281	BLOCK, air valve; acetal	1
10†◆	819.4284	PACKING, u-cup; nitrile	2
11	819.4285	PISTON, actuator; acetal	2
12	819.4286	BEARING, piston; acetal	2
15	819.4287	BEARING, pin; acetal	2
16	819.4288	PIN, pilot; SST	2
17†◆	819.4289	O-RING; buna-N	2
18†◆	819.4290	BLOCK, pilot; acetal	1
19	819.4291	BEARING, shaft; acetal	2
20	---	SCREW, grounding (See Ref. 3)	1
22	819.4294	GASKET, air cover; foam	2
23	819.0520	COVER, air, SST	2
24	819.0447	SHAFT, diaphragm; SST	1
25	819.4297	SCREW; M8 x 1.25; 25 mm (1 in.); stainless steel	10

† These parts are included in Air Valve Repair Kit 819.0667 (for models with stainless steel center housing), which may be purchased separately. Order part number 819.0184 for lithium-based grease.

◆ These parts are included in Air Valve Repair Kit 819.0666 (for models with aluminum center housing), which may be purchased separately. Order part number 819.0184 for lithium-based grease.

Fluid Section

Digit	Ref.	Part/Kit	Description	Qty	
S	101	819.0490	COVER, fluid	2	
	102		MANIFOLD, inlet	1	
		819.0493	End Port T4		
		819.0617	End Port D4		
	103		MANIFOLD, outlet	1	
		819.0494	End Port T4		
		819.0618	End Port D4		
	104		PLATE, air side		
		819.4373	Bolt-through diaphragm		2
		819.0534	Overmolded diaphragm		2
	105	819.0411	PLATE, diaphragm fluid SS	2	
	106	819.0522	COVER, clamp	2	
	107	819.4482	BOLT, M12 x 35; 35 mm (1.38 in.) SS	2	
108	819.4304	PACKING, o-ring, PTFE	2		
110▲	819.4313	LABEL, warning	1		
111	819.0519	MUFFLER	1		
113	819.0505	CLAMP, hygenic T6	4		

▲ Replacement Danger and Warning labels, tags, and cards are available at no cost.

Seat

Digit	Ref.	Part/Kit	Description	Qty
ST	201	819.0537	VA-H25 SS,--,TF-EP	1
	202	Included in above kit		
SE	201	819.0537	VA-H25 SS,--,TF-EP	1
	202	Included in above kit		

Ball

Digit	Ref.	Part/Kit	Description	Qty
TF	301	819.0426	VA-H25S --,TF,--,--	1
SP	301	819.0427	VA-H25S --,SP,--,--	1
NW	301	819.0545	VA-H25S --,NW,--,--	1

Continued on next page.

Diaphragm

Digit	Ref.	Part/Kit	Description	Qty
TF	403	819.0445	VA-H25S --,--,TF,--	1
	401	Included in above kit		
	402	819.4284	PACKING, VA25/40/50; u-cup; BN	2
SP	403	819.0461	VA-H25S --,--,SP,--	1
	401	Not required		
	402	819.4284	PACKING, VA25/40/50; u-cup; BN	2
TO	403	819.0570	VA-H25S --,--,TO,--	1
	401	Not required		
	402	819.4284	PACKING, VA25/40/50; u-cup; BN	2

Manifold O-Ring Kits

Digit	Ref.	Part/Kit	Description	Qty
TF	202	819.0550	VA-H25S --,--,TF	1
EP	202	819.0540	VA-H25S --,--,EP	1
VT-TF	202	819.1223	VA-H25S --,--,VT-TF	1

VA-H25 Fluid Section Repair Kits*

Tri-clamp Models	DIN Models	Repair Kit	Description
810.0792	810.0793	819.0585	VA-H25S --,TF,TF,TF
810.0794	810.0795	819.0586	VA-H25S --,TF,TO,TF
810.0802	810.0803	819.0585	VA-H25S --,TF,TF,TF
810.0804	810.0805	819.0588	VA-H25S --,NW,SP,TF
810.0806	810.0807	819.0592	VA-H25S --,SP,SP,EP
810.0808	810.0809	819.0592	VA-H25S --,SP,SP,EP
		819.0587	VA-H25S --,SP,SP,TF
		819.0589	VA-H25S --,NW,TO,TF
		819.0590	VA-H25S --,TF,TF,EP
		819.0591	VA-H25S --,TF,TO,EP
		819.0593	VA-H25S --,NW,SP,EP

* Order part number 819.0184 for lithium-based grease.

Dimensional Drawing, VA-H25 Models

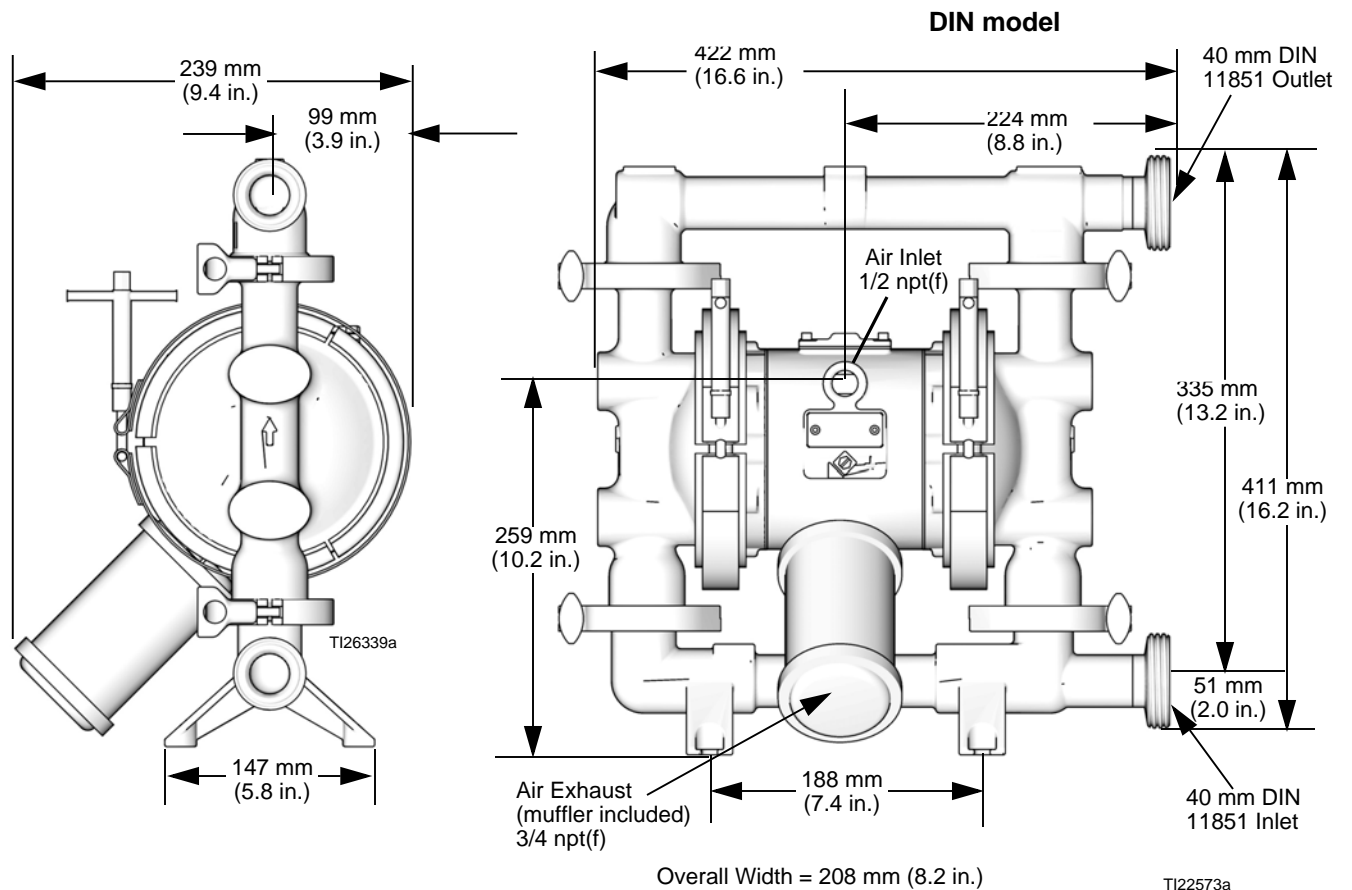
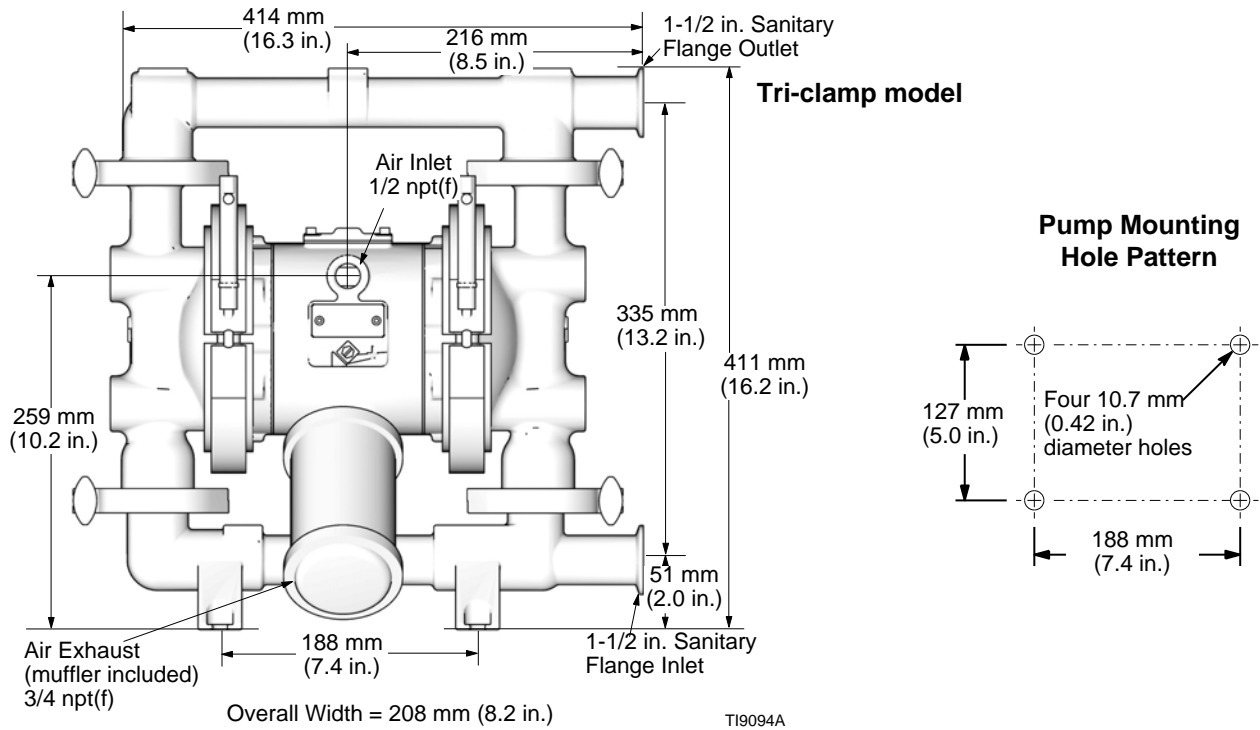

Technical Data, VA-H25 Models

	U.S.	Metric
Maximum fluid working pressure	120 psi	8 bar (0.8 MPa)
Air pressure operating range	20-120 psi	1.4-8 bar (0.14-0.8 MPa)
Maximum air consumption	50 scfm	1.4 Nm ³ /min
Operating air consumption	18 scfm at 70 psi/20 gpm	0.5 Nm ³ /min at 4.8 bar/75.7 lpm
Maximum free-flow delivery	41 gpm	155.2 l/min
Maximum pump speed		256 cpm
* Flow per cycle	0.16 gallons	0.606 liters
Maximum suction lift (varies widely based on ball/seat selection and wear, operating speed, material properties, and other variables)	29 ft wet 16 ft dry	8.83 m wet 4.87 m dry
Maximum size pumpable solids	1/8 in.	3.2 mm
** Maximum Noise Level at full flow (120 psi, 0.8 MPa)		92 dBa
** Sound Power Level		100 dBa
** Operating Noise Level	73 dBa at 70 psi and 50 cpm	73 dBa at 4.8 bar and 50 cpm
Maximum fluid operating temperature is based on the following maximum diaphragm, ball, and seat temperature ratings.		
PTFE	220°F	104.4°C
Santoprene	180°F	82.2°C
EPDM	275°F	135°C
Polychloroprene	200°F	93°C
Air inlet size		0.5 in. npt(f)
Wetted parts ***All fluid contact materials are FDA-compliant and meet the United States Code of Federal Regulations (CFR) Title 21, Section 177.		
Wetted materials on all models	316 SST	
Wetted material depending on model	EPDM, Polychloroprene, PTFE, Santoprene®	
CAUTION: Santoprene® may be used only with non-fatty, non-oily foods or alcohols up to 15%.		
Non-wetted external parts	300 series stainless steel, aluminum (A380), polyester (labels), LDPE foam (gasket)	
Weight		
SS Models	55 lb.	24.9 kg
SA Models	49 lb.	22.2 kg

Santoprene® is a registered trademark of the Monsanto Co.

* Displacement per cycle may vary based on suction condition, discharge head, air pressure, and fluid type.

** Noise levels measured with the pump mounted to a solid surface. Sound power measured per ISO Standard 9614-1.

*** The pump user must verify that the construction materials meet their specific application requirements.

Performance Chart, VA-H25 Models

Test Conditions: Pump tested in water with inlet submerged

Fluid Pressure Curves

- A** at 8.4 bar (0.84 MPa, 120 psi) operating air pressure
- B** at 7.0 bar (0.7 MPa, 100 psi) operating air pressure
- C** at 4.8 bar (0.5 MPa, 70 psi) operating air pressure
- D** at 2.8 bar (0.3 MPa, 40 psi) operating air pressure

To find Fluid Outlet Pressure

(bar/MPa/psi) at a specific fluid flow (lpm/gpm) and operating air pressure (bar/MPa/psi):

1. Locate fluid flow rate along bottom of chart.
2. Follow vertical line up to intersection with selected operating air pressure curve.
3. Follow left to scale to read fluid outlet pressure.

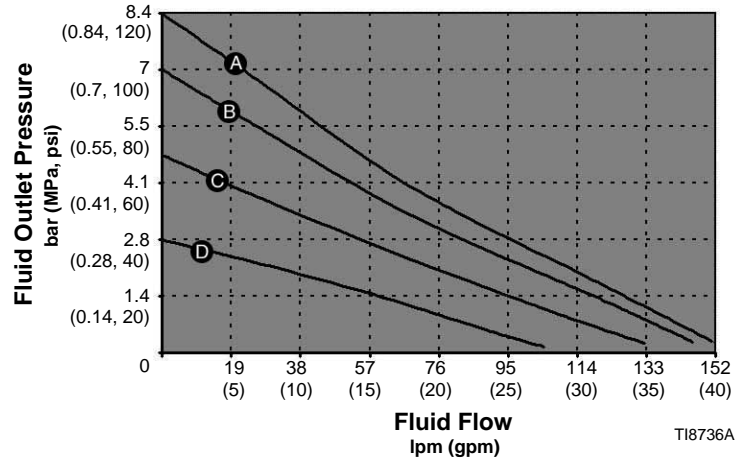

AIR PRESSURES	
(A)	= @ 120 psi (8.4 bar, 0.84 MPa)
(B)	= @ 100 psi (7.0 bar, 0.7 MPa)
(C)	= @ 70 psi (4.8 bar, 0.5 MPa)
(D)	= @ 40 psi (2.8 bar, 0.3 MPa)

T18736A

T18742A

Air Consumption Curves

- A** at 8.4 bar (0.84 MPa, 120 psi) operating air pressure
- B** at 7.0 bar (0.7 MPa, 100 psi) operating air pressure
- C** at 4.8 bar (0.5 MPa, 70 psi) operating air pressure
- D** at 2.8 bar (0.3 MPa, 40 psi) operating air pressure

To find Pump Air Consumption

(Nm³/min or scfm) at a specific fluid flow (lpm/gpm) and operating air pressure (bar/MPa/psi):

1. Locate fluid flow rate along bottom of chart.
2. Read vertical line up to intersection with selected operating air pressure curve.

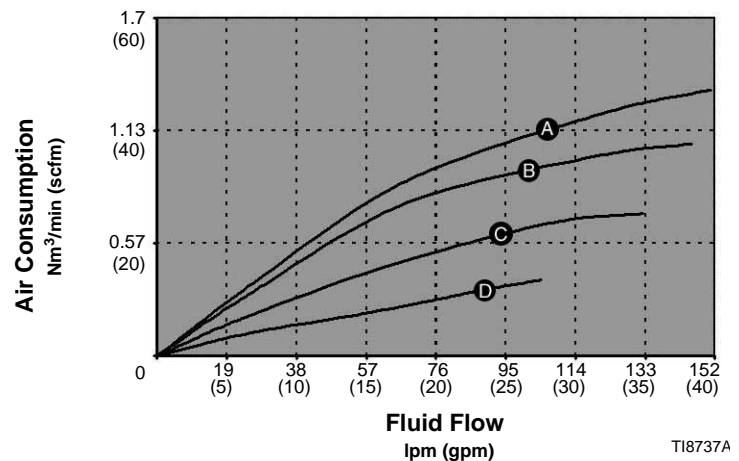

AIR PRESSURES	
(A)	= @ 120 psi (8.4 bar, 0.84 MPa)
(B)	= @ 100 psi (7.0 bar, 0.7 MPa)
(C)	= @ 70 psi (4.8 bar, 0.5 MPa)
(D)	= @ 40 psi (2.8 bar, 0.3 MPa)

T18737A

T18742A

Parts, VA-H40 Models

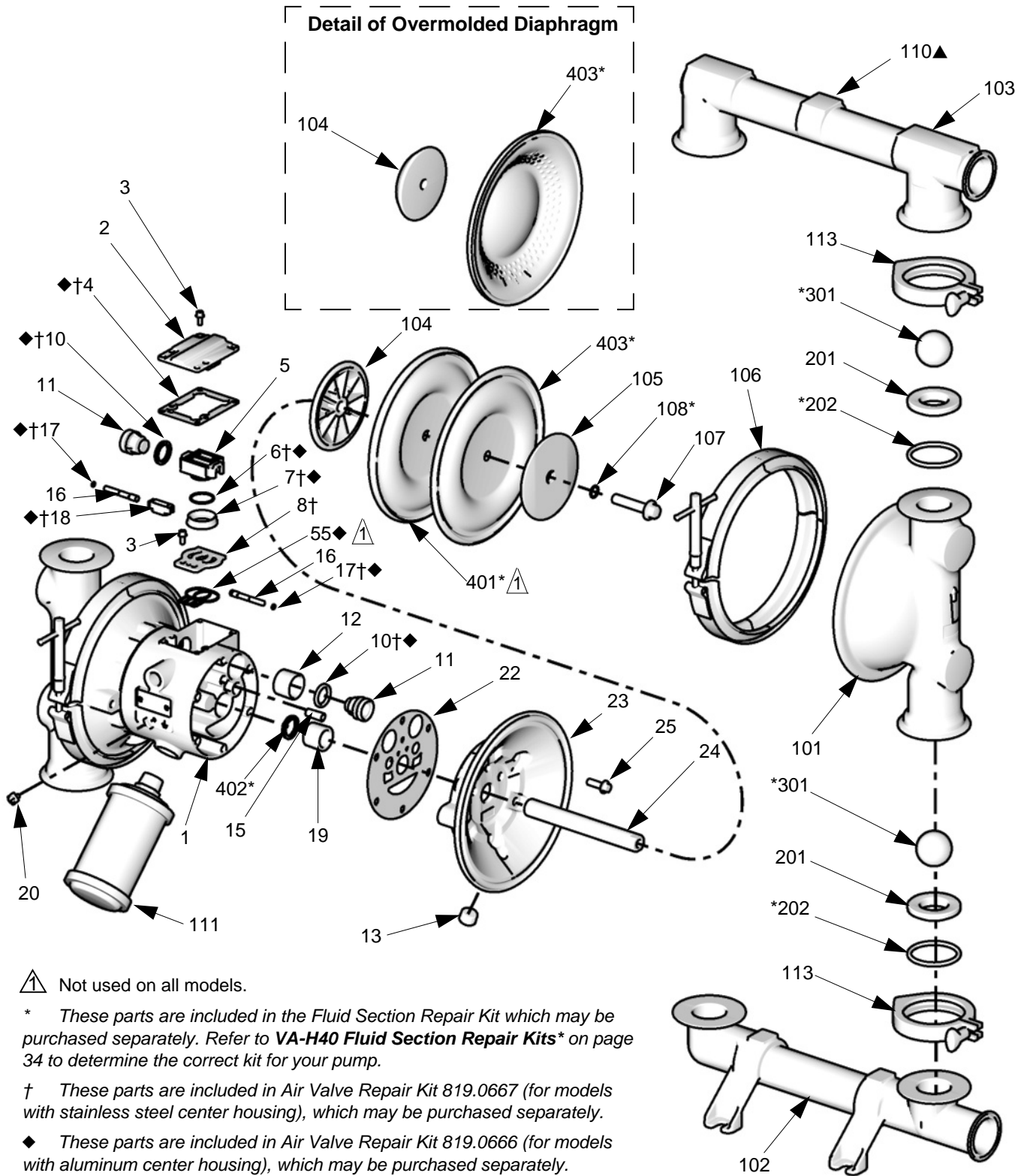

▲ Not used on all models.

* These parts are included in the Fluid Section Repair Kit which may be purchased separately. Refer to **VA-H40 Fluid Section Repair Kits*** on page 34 to determine the correct kit for your pump.

† These parts are included in Air Valve Repair Kit 819.0667 (for models with stainless steel center housing), which may be purchased separately.

◆ These parts are included in Air Valve Repair Kit 819.0666 (for models with aluminum center housing), which may be purchased separately.

▲ Replacement Danger and Warning labels, tags, and cards are available at no cost.

T18927b

Parts, VA-H40 Models, *continued*

Air Motor

Digit	Ref.	Part No.	Description	Qty
SS	1	819.0247	HOUSING, center; SST	1
	2	819.0259	COVER, air valve; SST	1
	8†	819.0248	PLATE, air valve; SST	1
SA	1	819.4275	HOUSING, center, aluminum	1
	2	819.4276	COVER, air valve; aluminum	1
	8	819.4282	PLATE, air valve, aluminum	1
	55◆	819.4274	SEAL, valve plate	1

Air Motor Common Parts

Ref.	Part No.	Description	Qty
3	819.0221	SCREW, mach, hex flange hd; M5 x 0.8; 12 mm (0.47 in.)	9
4†◆	819.4278	GASKET, cover	1
5	819.4279	CARRIAGE; aluminum	1
6†◆	819.4280	O-RING; nitrile	1
7†◆	819.4281	BLOCK, air valve; acetal	1
10†◆	819.4284	PACKING, u-cup; nitrile	2
11	819.4285	PISTON, actuator; acetal	2
12	819.4286	BEARING, piston; acetal	2
13	819.0419	PLUG, pipe	2
15	819.4287	BEARING, pin; acetal	2
16	819.4288	PIN, pilot; SST	2
17†◆	819.4289	O-RING; buna-N	2
18†◆	819.4290	BLOCK, pilot; acetal	1
19	819.4291	BEARING, shaft; acetal	2
20	---	SCREW, grounding (See Ref. 3)	1
22	819.4294	GASKET, air cover; foam	2
23	819.0668	COVER, air; SST	2
24	819.4337	SHAFT, diaphragm; SST	1
25	819.4297	SCREW; M8 x 1.25; 25 mm (1 in.); stainless steel	10

† These parts are included in Air Valve Repair Kit 819.0667 (for models with stainless steel center housing), which may be purchased separately. Order part number 819.0184 for lithium-based grease.

◆ These parts are included in Air Valve Repair Kit 819.0666 (for models with aluminum center housing), which may be purchased separately. Order part number 819.0184 for lithium-based grease.

Fluid Section

Digit	Ref.	Part/Kit	Description	Qty	
S	101	819.0491	COVER, fluid	2	
	102		MANIFOLD, inlet	1	
		819.0495	End Port T5		
		819.0619	End Port D5		
	103		MANIFOLD, outlet	1	
		819.0496	End Port T5		
		819.0620	End Port D5		
	104		PLATE, air side		
		819.0258	Bolt-through diaphragm		2
		819.0535	Overmolded diaphragm		2
	105	819.4348	PLATE, diaphragm fluid SS	2	
	106	819.0523	COVER, clamp	2	
	107	819.4343	SCREW, M10 x 1.50; 30 mm (1.18 in.) SS	2	
108	819.4304	PACKING, o-ring, PTFE	2		
110▲	819.6311	LABEL, warning	1		
111	819.0519	MUFFLER	1		
113	819.0516	CLAMP, hygenic T8	4		

▲ Replacement Danger and Warning labels, tags and cards are available at no cost.

Seat

Digit	Ref.	Part/Kit	Description	Qty
ST	201	819.0538	VA-H40 SS,--,TF-EP	1
	202	Included in above kit		
SE	201	819.0538	VA-H40 SS,--,TF-EP	1
	202	Included in above kit		

Ball

Digit	Ref.	Part/Kit	Description	Qty
TF	301	819.0432	VA-H40S --,TF,--,--	1
SP	301	819.0433	VA-H40S --,SP,--,--	1
NW	301	819.0546	VA-H40S --,NW,--,--	1

Continued on next page.

Diaphragm

Digit	Ref.	Part/Kit	Description	Qty
TF	403	819.0554	VA-H40S --,--,TF,--	1
	401	Included in above kit		
	402	819.4284	PACKING, VA25/40/50; u-cup; BN	2
SP	403	819.0574	VA-H40S --,--,SP,--	1
	401	Not required		
	402	819.4284	PACKING, VA25/40/50; u-cup; BN	2
TO	403	819.0571	VA-H40S --,--,TO,--	1
	401	Not required		
	402	819.4284	PACKING, VA25/40/50; u-cup; BN	2

Manifold O-Ring Kits

Digit	Ref.	Part/Kit	Description	Qty
TF	202	819.0543	VA-H40S --,--,TF	1
EP	202	819.0541	VA-H40S --,--,EP	1
VT-TF	202	819.1224	VA-H40S --,--,VT-TF	1

VA-H40 Fluid Section Repair Kits*

Tri-clamp Models	DIN Models	Repair Kit	Description
810.0796	810.0797	819.0594	VA-H40S --,TF,TF,TF
810.0798	810.0799	819.0594	VA-H40S --,TF,TF,TF
810.0800	810.0801	819.0595	VA-H40S --,TF,TO,TF
810.0810	810.0811	819.0597	VA-H40S --,NW,SP,TF
810.0812	810.0813	819.0601	VA-H40S --,SP,SP,EP
810.0814	810.0815	819.0601	VA-H40S --,SP,SP,EP
		819.0596	VA-H40S --,SP,SP,TF
		819.0597	VA-H40S --,NW,SP,TF
		819.0598	VA-H40S --,NW,TO,TF
		819.0599	VA-H40S --,TF,TF,EP
		819.0600	VA-H40S --,TF,TO,EP
		819.0602	VA-H40S --,NW,SP,EP

* Order part number 819.0184 for lithium-based grease.

Dimensional Drawing, VA-H40 Models

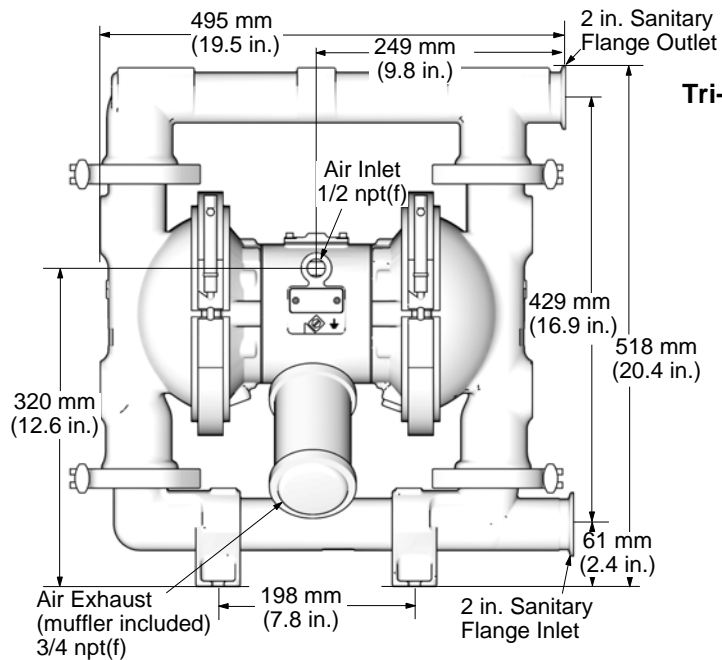

Tri-clamp model

Pump Mounting Hole Pattern

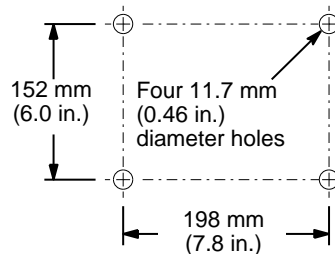

Overall Width = 257 mm (10.1 in.)

T19095a

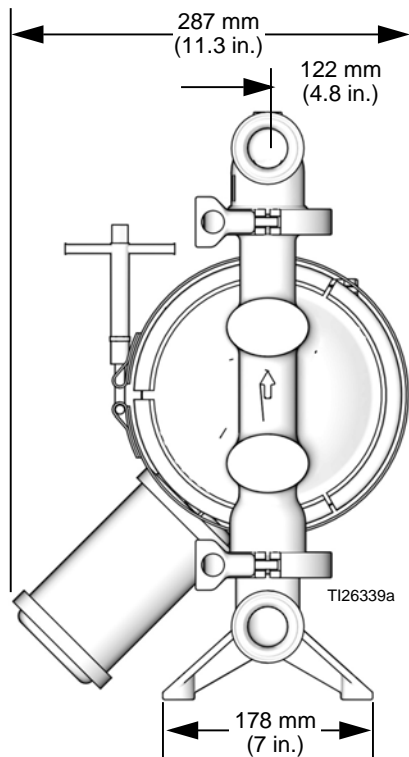

T126339a

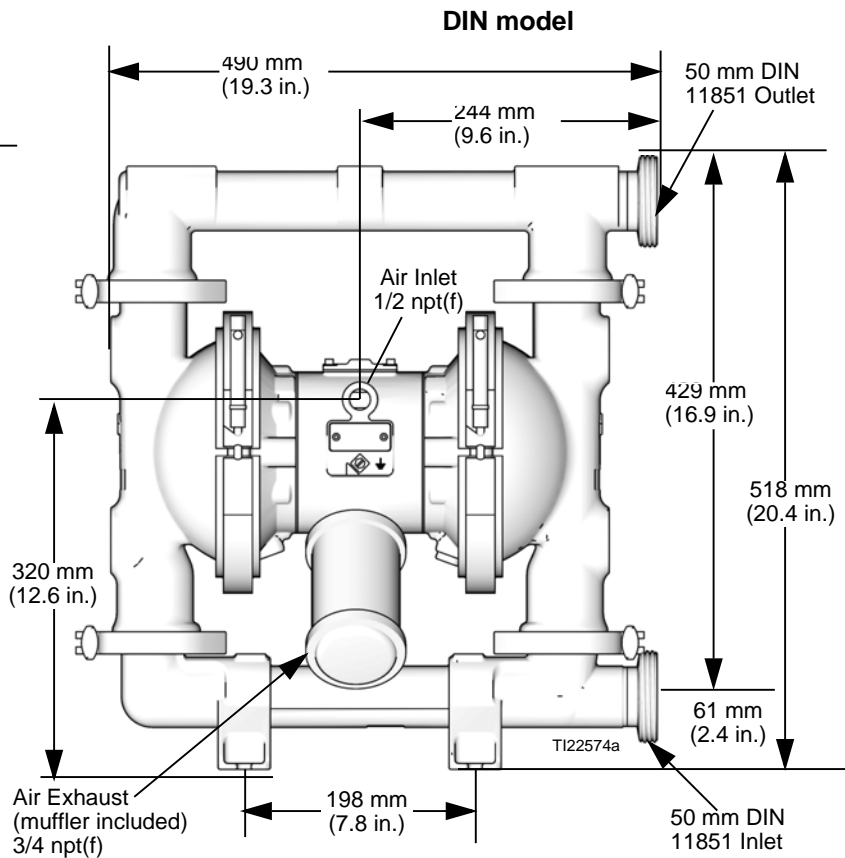

DIN model

T122574a

Overall Width = 257 mm (10.1 in.)

Technical Data, VA-H40 Models

	U.S.	Metric
Maximum fluid working pressure	120 psi	8 bar (0.8 MPa)
Air pressure operating range	20-120 psi	1.4-8 bar (0.14-0.8 MPa)
Maximum air consumption	130 scfm	3.7 Nm ³ /min
Operating air consumption	42 scfm at 70 psi/50 gpm	1.2 Nm ³ /min at 4.8 bar/189 lpm
Maximum free-flow delivery	117 gpm	443 l/min
Maximum pump speed	200 cpm	
* Flow per cycle	0.6 gallons	2.2 liters
Maximum suction lift (varies widely based on ball/seat selection and wear, operating speed, material properties, and other variables)	29 ft wet 14 ft dry	8.83 m wet 4.26 m dry
Maximum size pumpable solids	3/16 in.	4.8 mm
** Maximum Noise Level at full flow (120 psi, 0.8 MPa)	88 dBa	
** Sound Power Level	95 dBa	
** Operating Noise Level	79 dBa at 70 psi and 50 cpm	79 dBa at 4.8 bar and 50 cpm
Maximum fluid operating temperature is based on the following maximum diaphragm, ball, and seat temperature ratings.		
PTFE	220°F	104.4°C
Santoprene	180°F	82.2°C
EPDM	275°F	135°C
Polychloroprene	200°F	93°C
Air inlet size	0.5 in. npt(f)	
Wetted parts ***All fluid contact materials are FDA-compliant and meet the United States Code of Federal Regulations (CFR) Title 21, Section 177.		
Wetted materials on all models	316 SST	
Wetted material depending on model	EPDM, Polychloroprene, PTFE, Santoprene®	
CAUTION: Santoprene® may be used only with non-fatty, non-oily foods or alcohols up to 15%.		
Non-wetted external parts	300 series stainless steel, aluminum (A380), polyester (labels), LDPE foam (gasket)	
Weight		
SS Models	89 lb.	40.3 kg
SA Models	83 lb.	37.6 kg

Santoprene® is a registered trademark of the Monsanto Co.

* Displacement per cycle may vary based on suction condition, discharge head, air pressure, and fluid type.

** Noise levels measured with the pump mounted to a solid surface. Sound power measured per ISO Standard 9614-1.

*** The pump user must verify that the construction materials meet their specific application requirements.

Performance Chart, VA-H40 Models

Test Conditions: Pump tested in water with inlet submerged

Fluid Pressure Curves

- A** at 8.4 bar (0.84 MPa, 120 psi) operating air pressure
- B** at 7.0 bar (0.7 MPa, 100 psi) operating air pressure
- C** at 4.8 bar (0.5 MPa, 70 psi) operating air pressure
- D** at 2.8 bar (0.3 MPa, 40 psi) operating air pressure

To find Fluid Outlet Pressure

(bar/MPa/psi) at a specific fluid flow (lpm/gpm) and operating air pressure (bar/MPa/psi):

1. Locate fluid flow rate along bottom of chart.
2. Follow vertical line up to intersection with selected operating air pressure curve.

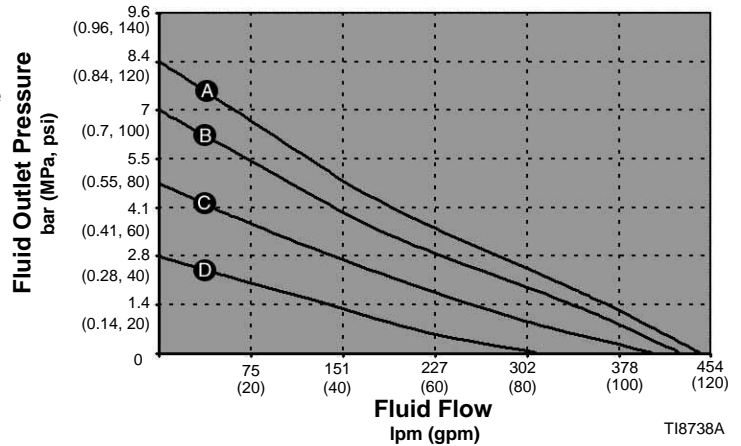

AIR PRESSURES	
(A)	= @ 120 psi (8.4 bar, 0.84 MPa)
(B)	= @ 100 psi (7.0 bar, 0.7 MPa)
(C)	= @ 70 psi (4.8 bar, 0.5 MPa)
(D)	= @ 40 psi (2.8 bar, 0.3 MPa)

T18738A

T18742A

Air Consumption Curves

- A** at 8.4 bar (0.84 MPa, 120 psi) operating air pressure
- B** at 7.0 bar (0.7 MPa, 100 psi) operating air pressure
- C** at 4.8 bar (0.5 MPa, 70 psi) operating air pressure
- D** at 2.8 bar (0.3 MPa, 40 psi) operating air pressure

To find Pump Air Consumption

(Nm³/min or scfm) at a specific fluid flow (lpm/gpm) and operating air pressure (bar/MPa/psi):

1. Locate fluid flow rate along bottom of chart.
2. Read vertical line up to intersection with selected operating air pressure.
3. Follow left to scale to read air consumption.

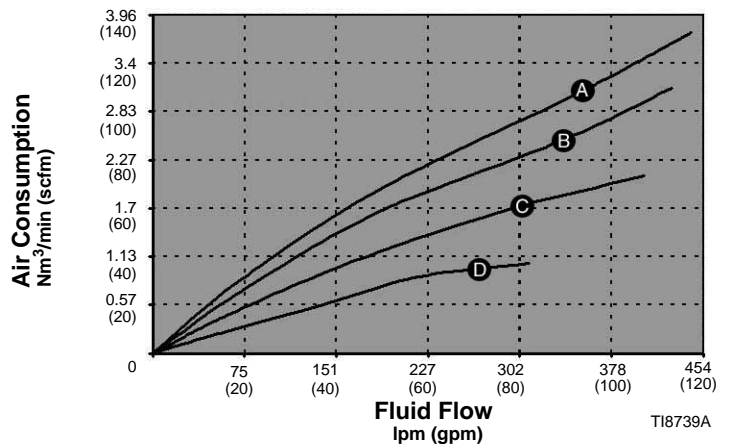

AIR PRESSURES	
(A)	= @ 120 psi (8.4 bar, 0.84 MPa)
(B)	= @ 100 psi (7.0 bar, 0.7 MPa)
(C)	= @ 70 psi (4.8 bar, 0.5 MPa)
(D)	= @ 40 psi (2.8 bar, 0.3 MPa)

T18739A

T18742A

Parts, VA-H50 Models

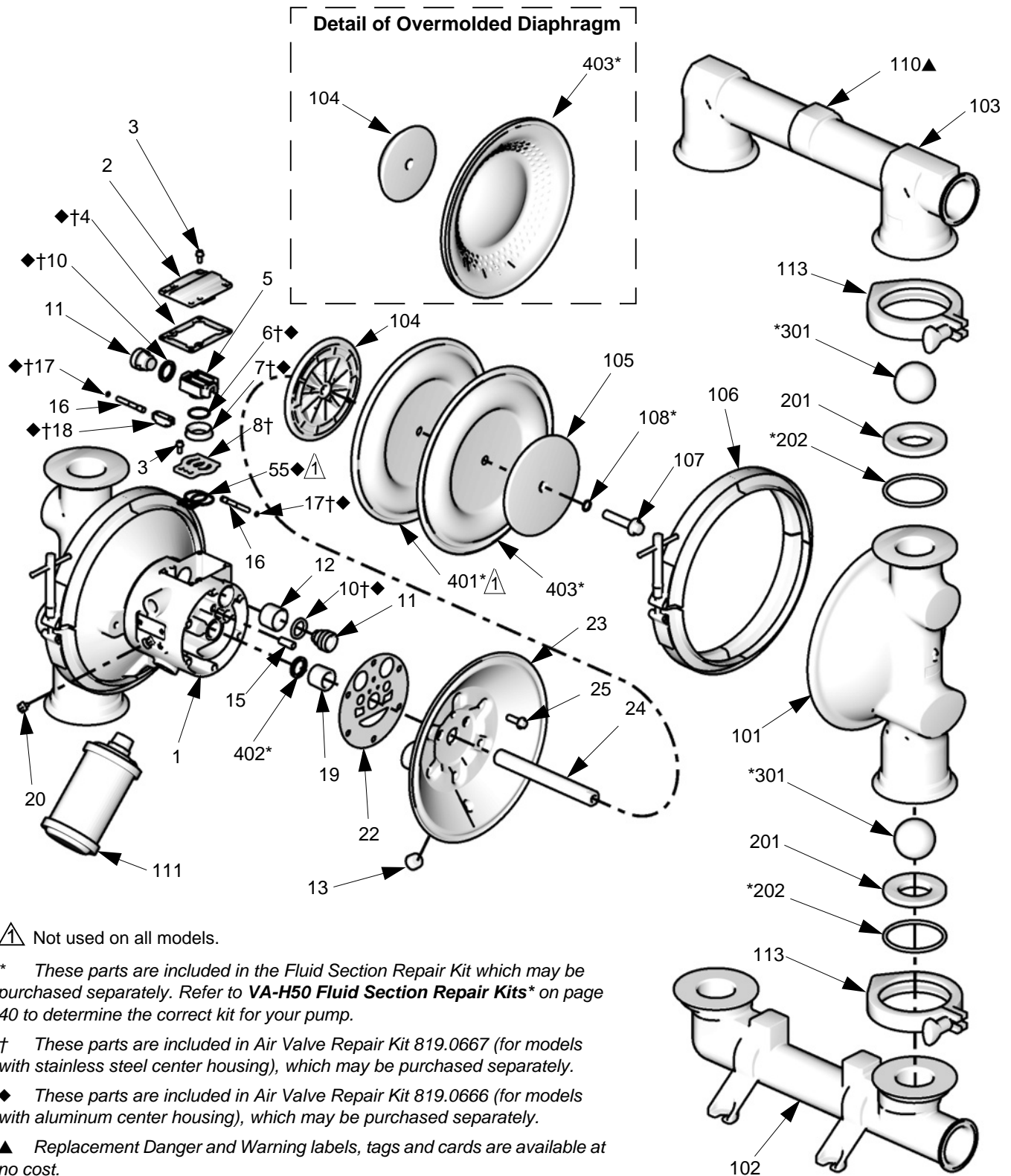

▲ Not used on all models.

* These parts are included in the Fluid Section Repair Kit which may be purchased separately. Refer to **VA-H50 Fluid Section Repair Kits*** on page 40 to determine the correct kit for your pump.

† These parts are included in Air Valve Repair Kit 819.0667 (for models with stainless steel center housing), which may be purchased separately.

◆ These parts are included in Air Valve Repair Kit 819.0666 (for models with aluminum center housing), which may be purchased separately.

▲ Replacement Danger and Warning labels, tags and cards are available at no cost.

T18929b

Parts, VA-H50 Models, *continued*

Air Motor

Digit	Ref.	Part No.	Description	Qty
SS	1	819.0247	HOUSING, center; SST	1
	2	819.0259	COVER, air valve; SST	1
	8†	819.0248	PLATE, air valve; SST	1
SA	1	819.4275	HOUSING, center, aluminum	1
	2	819.4276	COVER, air valve; aluminum	1
	8	819.4282	PLATE, air valve, aluminum	1
	55◆	819.4274	SEAL, valve plate	1

Air Motor Common Parts

Ref.	Part No.	Description	Qty
3	819.0221	SCREW, mach, hex flange hd; M5 x 0.8; 12 mm (0.47 in.)	9
4†◆	819.4278	GASKET, cover	1
5	819.4279	CARRIAGE; aluminum	1
6†◆	819.4280	O-RING; nitrile	1
7†◆	819.4281	BLOCK, air valve; acetal	1
10†◆	819.4284	PACKING, u-cup; nitrile	2
11	819.4285	PISTON, actuator; acetal	2
12	819.4286	BEARING, piston; acetal	2
13	819.0419	PLUG, pipe	2
15	819.4287	BEARING, pin; acetal	2
16	819.4288	PIN, pilot; SST	2
17†◆	819.4289	O-RING; buna-N	2
18†◆	819.4290	BLOCK, pilot; acetal	1
19	819.4291	BEARING, shaft; acetal	2
20	---	SCREW, grounding (See Ref. 3)	1
22	819.4294	GASKET, air cover; foam	2
23	819.0547	COVER, air; SST	2
24	819.4296	SHAFT, diaphragm; SST	1
25	819.4297	SCREW; M8 x 1.25; 25 mm (1 in.); stainless steel	10

† These parts are included in Air Valve Repair Kit 819.0667 (for models with stainless steel center housing), which may be purchased separately. Order part number 819.0184 for lithium-based grease.

◆ These parts are included in Air Valve Repair Kit 819.0666 (for models with aluminum center housing), which may be purchased separately. Order part number 819.0184 for lithium-based grease.

Fluid Section

Digit	Ref.	Part/Kit	Description	Qty	
S	101	819.0492	COVER, fluid	2	
	102		MANIFOLD, inlet	1	
		819.0497	End Port T6		
		819.0621	End Port D6		
	103		MANIFOLD, outlet	1	
		819.0498	End Port T6		
		819.0622	End Port D6		
	104		PLATE, air side		
		819.4301	Bolt-through diaphragm		2
		819.0536	Overmolded diaphragm		2
	105	819.4311	PLATE, diaphragm fluid SS	2	
	106	819.0532	COVER, clamp	2	
	107	819.4343	SCREW, M10 x 1.50; 30 mm (1.18 in.) SS	2	
108	819.4304	PACKING, o-ring, PTFE	2		
110▲	819.6311	LABEL, warning	1		
111	819.0519	MUFFLER	1		
113	819.0516	CLAMP, hygenic T1	4		

▲ Replacement Danger and Warning labels, tags and cards are available at no cost.

Seat

Digit	Ref.	Part/Kit	Description	Qty
ST	201	819.0539	VA-H50 SS,--,TF-EP	1
	202	Included in above kit		
SE	201	819.0539	VA-H50 SS,--,TF-EP	1
	202	Included in above kit		

Ball

Digit	Ref.	Part/Kit	Description	Qty
TF	301	819.0430	VA-H50S --,TF,--,--	1
SP	301	819.0431	VA-H50S --,SP,--,--	1
NW	301	819.0670	VA-H50S --,NW,--,--	1

Continued on next page.

Diaphragm

Digit	Ref.	Part/Kit	Description	Qty
TF	403	819.0671	VA-H50S --,--,TF,--	1
	401	Included in above kit		
	402	819.4284	PACKING, VA25/40/50; u-cup; BN	2
SP	403	819.0464	VA-H50S --,--,SP,--	1
	401	Not required		
	402	819.4284	PACKING, VA25/40/50; u-cup; BN	2
TO	403	819.0572	VA-H50S --,--,TO,--	1
	401	Not required		
	402	819.4284	PACKING, VA25/40/50; u-cup; BN	2

Manifold O-Ring Kits

Digit	Ref.	Part/Kit	Description	Qty
TF	202	819.0544	VA-H50S --,--,TF	1
EP	202	819.0542	VA-H50S --,--,EP	1
VT-TF	202	819.1225	VA-H50S --,--,VT-TF	1

VA-H50 Fluid Section Repair Kits*

Tri-clamp Models	DIN Models	Repair Kit	Description
810.0816	810.0817	819.0603	VA-H50S --,TF,TF,TF
810.0820	810.0821	819.0603	VA-H50S --,TF,TF,TF
810.0818	810.0819	819.0606	VA-H50S --,NW,SP,TF
810.0822	810.0823	819.0604	VA-H50S --,TF,TO,TF
		819.0605	VA-H50S --,SP,SP,TF
		819.0607	VA-H50S --,NW,TO,TF
		819.0608	VA-H50S --,TF,TF,EP

* Order part number 819.0184 for lithium-based grease.

Dimensional Drawing, VA-H50

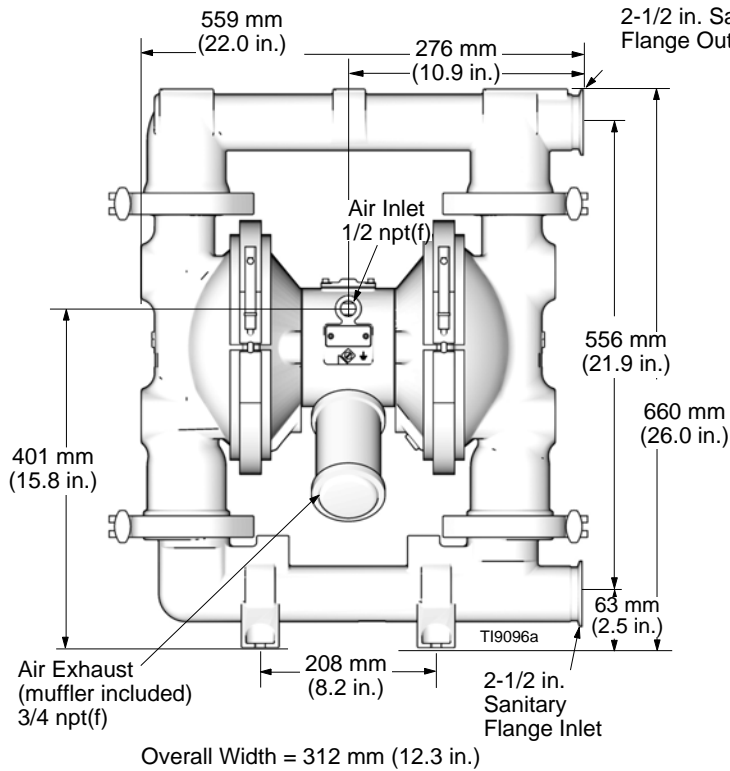

Tri-clamp model

Pump Mounting Hole Pattern

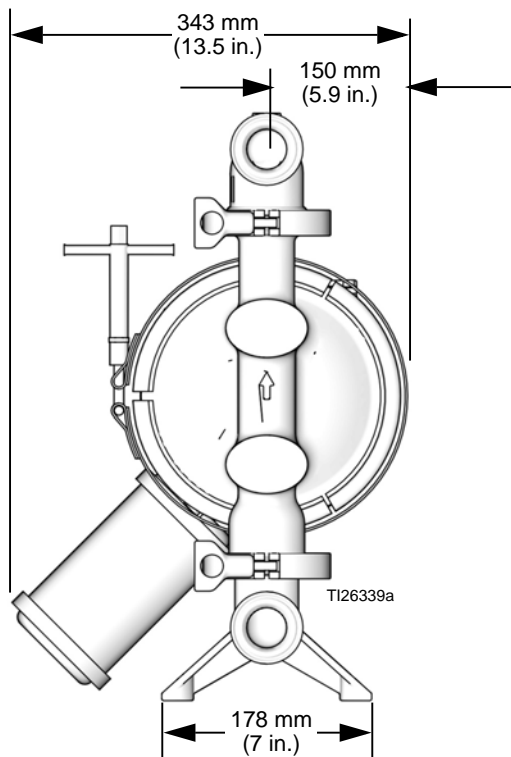
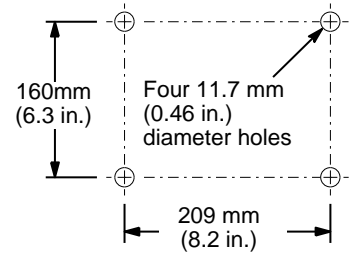

DIN model

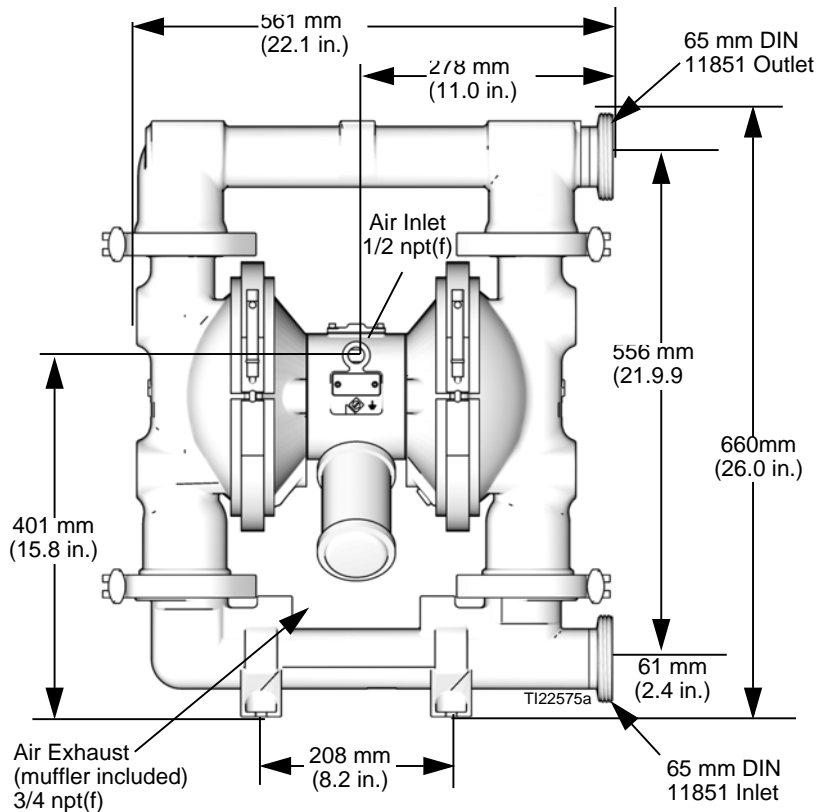

Overall Width = 257 mm (10.1 in.)

Technical Data, VA-H50 Models

	U.S.	Metric
Maximum fluid working pressure	120 psi	8 bar (0.8 MPa)
Air pressure operating range	20-120 psi	1.4-8 bar (0.14-0.8 MPa)
Maximum air consumption	175 scfm	4.9 Nm ³ /min
Operating air consumption	70 scfm at 70 psi/80gpm	1.98 Nm ³ /min at 4.8 bar/303 lpm
Maximum free-flow delivery	160 gpm	606 l/min
Maximum pump speed	165 cpm	
* Flow per cycle	0.97 gallons	3.67 liters
Maximum suction lift (varies widely based on ball/seat selection and wear, operating speed, material properties, and other variables)	29 ft wet 16 ft dry	8.83 m wet 4.87 m dry
Maximum size pumpable solids	1/4 in.	6.3 mm
** Maximum Noise Level at full flow (120 psi, 0.8 MPa)	95 dBa	
** Sound Power Level	102 dBa	
** Operating Noise Level	84 dBa at 70 psi and 50 cpm	84 dBa at 4.8 bar and 50 cpm
Maximum fluid operating temperature is based on the following maximum diaphragm, ball, and seat temperature ratings.		
PTFE	220°F	104.4°C
Santoprene	180°F	82.2°C
EPDM	275°F	135°C
Polychloroprene	200°F	93°C
Air inlet size	0.5 in. npt(f)	
Wetted parts ***All fluid contact materials are FDA-compliant and meet the United States Code of Federal Regulations (CFR) Title 21, Section 177.		
Wetted materials on all models	316 SST	
Wetted material depending on model	EPDM, Polychloroprene, PTFE, Santoprene®	
CAUTION: Santoprene® may be used only with non-fatty, non-oily foods or alcohols up to 15%.		
Non-wetted external parts	300 series stainless steel, aluminum (A380), polyester (labels), LDPE foam (gasket)	
Weight		
SS Models	147 lb.	66.7 kg
SA Models	141 lb.	64.0 kg

Santoprene® is a registered trademark of the Monsanto Co.

* Displacement per cycle may vary based on suction condition, discharge head, air pressure, and fluid type.

** Noise levels measured with the pump mounted to a solid surface. Sound power measured per ISO Standard 9614-1.

*** The pump user must verify that the construction materials meet their specific application requirements.

Performance Chart, VA-H50 Models

Test Conditions: Pump tested in water with inlet submerged

Fluid Pressure Curves

- A** at 8.4 bar (0.84 MPa, 120 psi) operating air pressure
- B** at 7.0 bar (0.7 MPa, 100 psi) operating air pressure
- C** at 4.8 bar (0.5 MPa, 70 psi) operating air pressure
- D** at 2.8 bar (0.3 MPa, 40 psi) operating air pressure

To find Fluid Outlet Pressure

(bar/MPa/psi) at a specific fluid flow (lpm/gpm) and operating air pressure (bar/MPa/psi):

1. Locate fluid flow rate along bottom of chart.
2. Follow vertical line up to intersection with selected operating air pressure curve.
3. Follow left to scale to read fluid outlet pressure.

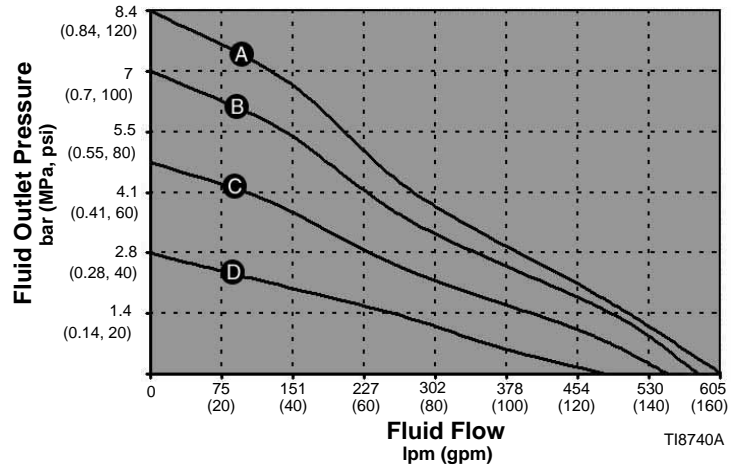

AIR PRESSURES	
(A)	= @ 120 psi (8.4 bar, 0.84 MPa)
(B)	= @ 100 psi (7.0 bar, 0.7 MPa)
(C)	= @ 70 psi (4.8 bar, 0.5 MPa)
(D)	= @ 40 psi (2.8 bar, 0.3 MPa)

T18740A
T18742A

Air Consumption Curves

- A** at 8.4 bar (0.84 MPa, 120 psi) operating air pressure
- B** at 7.0 bar (0.7 MPa, 100 psi) operating air pressure
- C** at 4.8 bar (0.5 MPa, 70 psi) operating air pressure
- D** at 2.8 bar (0.3 MPa, 40 psi) operating air pressure

To find Pump Air Consumption

(Nm³/min or scfm) at a specific fluid flow (lpm/gpm) and operating air pressure (bar/MPa/psi):

1. Locate fluid flow rate along bottom of chart.
2. Read vertical line up to intersection with selected operating air pressure curve.
3. Follow left to scale to read air consumption.

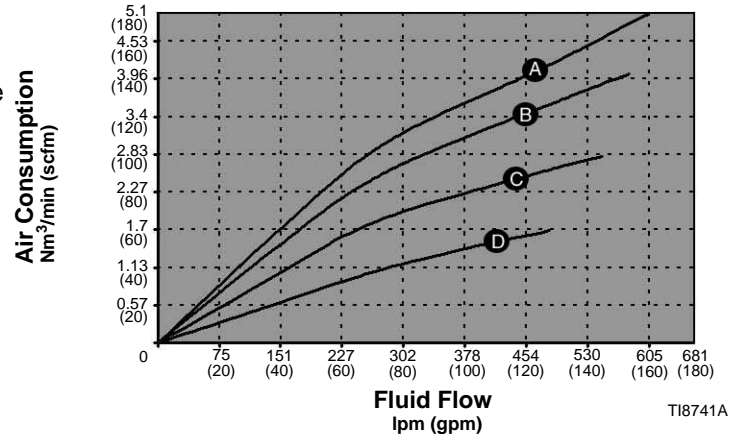

AIR PRESSURES	
(A)	= @ 120 psi (8.4 bar, 0.84 MPa)
(B)	= @ 100 psi (7.0 bar, 0.7 MPa)
(C)	= @ 70 psi (4.8 bar, 0.5 MPa)
(D)	= @ 40 psi (2.8 bar, 0.3 MPa)

T18741A
T18742A

Customer Services/Guarantee

CUSTOMER SERVICES

If you require spare parts, please contact your local distributor, providing the following details:

- Pump Model
- Type
- Serial Number, and
- Date of First Order.

GUARANTEE

All VERDER pumps are warranted to the original user against defects in workmanship or materials under normal use (rental use excluded) for two years after purchase date. This warranty does not cover failure of parts or components due to normal wear, damage or failure which in the judgement of VERDER arises from misuse.

Parts determined by VERDER to be defective in material or workmanship will be repaired or replaced.

LIMITATION OF LIABILITY

To the extent allowable under applicable law, VERDER's liability for consequential damages is expressly disclaimed. VERDER's liability in all events is limited and shall not exceed the purchase price.

WARRANTY DISCLAIMER

VERDER has made an effort to illustrate and describe the products in the enclosed brochure accurately; however, such illustrations and descriptions are for the sole purpose of identification and do not express or imply a warranty that the products are merchantable, or fit for a particular purpose, or that the products will necessarily conform to the illustration or descriptions.

PRODUCT SUITABILITY

Many regions, states and localities have codes and regulations governing the sale, construction, installation and/or use of products for certain purposes, which may vary from those in neighboring areas. While VERDER attempts to assure that its products comply with such codes, it cannot guarantee compliance, and cannot be responsible for how the product is installed or used. Before purchasing and using a product, please review the product application as well as the national and local codes and regulations, and be sure that product, installation, and use complies with them.

Original instructions. This manual contains English.
Revision K, December 2019

Austria

Verder Austria
Eitnergasse 21/Top 8
A-1230 Wien
AUSTRIA
Tel: +43 1 86 51 074 0
Fax: +43 1 86 51 076
e-mail: office@verder.at

Belgium

Verder nv
Kontichsesteenweg 17
B-2630 Aartselaar
BELGIUM
Tel: +32 3 877 11 12
Fax: +32 3 877 05 75
e-mail: info@verder.be

China

Verder Retsch Shanghai Trading
Building 8
Fuhai Business Park No. 299
Bisheng Road, Zhangjiang Hiteck Park
Shanghai 20120
CHINA
Tel: +86 (0)21 33 93 29 50 / 33 93 29 51
Fax: +86 (0)21 33 93 29 55
e-mail: info@verder.cn

Bulgaria

Verder Bulgaria Ltd
Vitosh department,
Manastriski Livadi Zapad
district,
110 Bulgaria Blvd., 2-nd
Floor, apt. 15-16,
1618 - Sofia
BULGARIA
Tel: 0878407370
Fax: 02 9584085
email: office@verder.bg

Czech Republic

Verder s.r.o.
Vodnanská 651/6 (vchod
Chlumecka 15)
198 00 Praha 9-Kyje
CZECH REPUBLIC
Tel: +420 261 225 386-7
Web: <http://www.verder.cz>
e-mail: info@verder.cz

France

Verder France
8 Allée Rosa Luxembourg,
Immeulde Arizona
95610 Eragny sur Oise
FRANCE
Tel: +33 173 43 98 41
Fax: +33 134 64 44 50
e-mail: info@verder.fr

Germany

Verder Deutschland GmbH
Retsch-Allee 1-5
D-42781 Haan
GERMANY
Tel: 02104/2333-200
Fax: 02104/2333-299
e-mail: info@verder.de

Hungary

Verder Hungary Kft
Budafoke ut 187 - 189
HU-1117 Budapest
HUNGARY
Tel: 0036 1 3651140
Fax: 0036 1 3725232
e-mail: info@verder.hu

India

Verder India Pumps PVT.
LTD
Plot No-3b+3part 11,
D-1 Block, MIDC Block
Chinchwad, Pune - 411019
INDIA
Tel: +91 20 64104466
e-mail: Sales@verder.co.in
www.verder.co.in

Italy

Verder Italia
Via Maestri del Lavoro,
5 Vazia, Rieti
ITALY
Tel: +39 0746 221224-
e-mail: info@verder.it

The Netherlands

Verder BV
Leningradweg 5
NL 9723 TP Groningen
THE NETHERLANDS
Tel: +31 50 549 59 00
Fax: +31 50 549 59 01
e-mail: info@verder.nl

Poland

Verder Polska
ul.Porcelanowa 23
PL-40 036 Katowice
POLAND
Tel: +48 32 78 15 032
Fax: +48 32 78 15 034
e-mail: verder@verder.pl

Romania

Verder România
Drumul Balta Doamnei
no 57-61
Sector 3
CP 72-117
032624 Bucuresti
ROMANIA
Tel: +40 21 335 45 92
Fax: +40 21 337 33 92
e-mail: office@verder.ro

Slovak Republik

Verder Slovakia s.r.o.
Silacska 1
SK-831 02 Bratislava
SLOVAK REPUBLIK
Tel: +421 2 4463 07 88
Fax: +421 2 4445 65 78
e-mail: info@verder.sk

South Africa

Verder SA
197 Flaming Rock Avenue
Northlands Business Park
Newmarket Street
ZA Northriding
SOUTH AFRICA
Tel: +27 11 704 7500
Fax: +27 11 704 7515
e-mail: info@verder.co.za

Switzerland

Verder Deutschland GmbH
Sales Switzerland
Retsch-Allee 1-5
D-42781 Haan
GERMANY
Tel: +41 (0)61 331 33 13
Fax: +41 (0)61 331 63 22
e-mail: info@verder.ch

United Kingdom

Verder UK Ltd.
Unit 3 California Drive
Castleford, WF10 5QH
UNITED KINGDOM
Tel: +44 (0) 1924 221 001
Fax: +44 (0) 1132 465 649
e-mail: info@verder.co.uk

United States of America

Verder Inc.
110 Gateway Drive
Macon, GA 31210
USA
Toll Free: 1 877 7 VERDER
Tel: +1 478 471 7327
Fax: +1 478 476 9867
e-mail: info@verder.com