

# Verderair VA 25HP 2:1 Air-Operated Diaphragm Pump

859.0391  
Rev.K  
EN

1-inch high-pressure pump with modular air valve for fluid transfer applications. For professional use only.



### Important Safety Instructions

Read all warnings and instructions in this manual and in your Operation manual. **Save these instructions.**

*Maximum Fluid Working Pressure:*  
17.2 bar (1.72 MPa, 250 psi)

*Maximum Air Input Pressure:*  
8.6 bar (0.86 MPa, 125 psi)

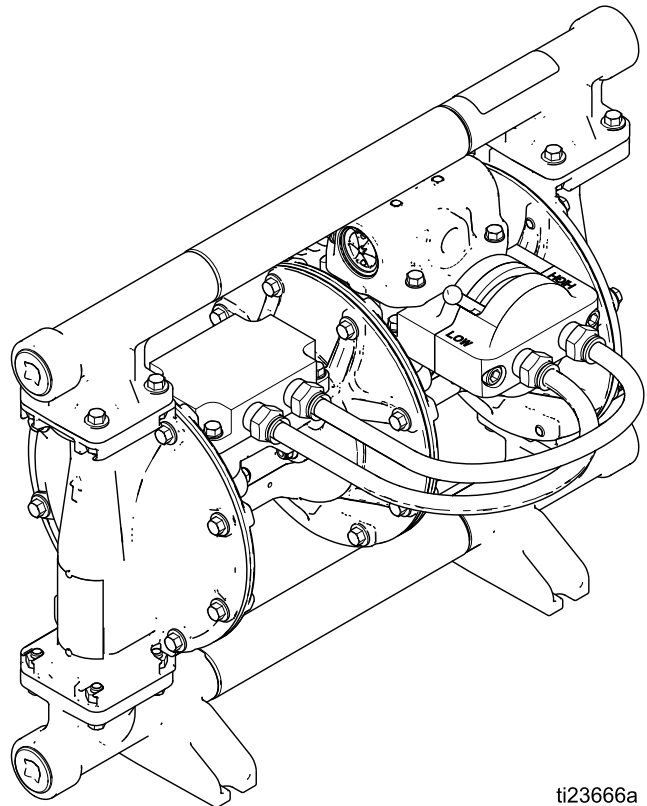

ti23666a



# Contents

Related Manuals .....	2	Check Valve Repair .....	16
Configuration Number Matrix .....	3	Diaphragm and Center Section Repair .....	17
Warnings .....	5	Torque Instructions .....	22
Troubleshooting .....	8	Parts .....	23
Repair .....	10	Seat, Check Ball, and Diaphragm Kits .....	41
Pressure Relief Procedure .....	10	Technical Data .....	42
Replace Complete Air Valve .....	10	Fluid Temperature Range .....	43
Replace Seals or Rebuild Air Valve .....	12	Customer Services/Guarantee .....	45
Replace Complete High/Low Valve .....	14		
Replace Seals or Rebuild the High/Low Valve .....	15		

## Related Manuals

Manual No.	Description
859.0390	Verderair VA 25HP 2:1 Air-Operated Diaphragm Pump, Operation

# Configuration Number Matrix

Check the identification plate (ID) for the 20-digit Configuration Number of your pump. Use the following matrix to define the components of your pump.

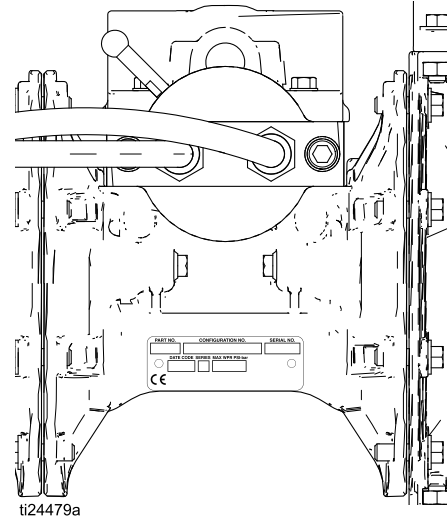

**Sample Configuration Number: VA25HPAA-SSSPPTB00**



<b>VA 25HP</b>	<b>A</b>	<b>A</b>	<b>SS</b>	<b>SP</b>	<b>SP</b>	<b>TB</b>	<b>00</b>
Pump Model	Fluid Section	Air Section	Seats	Balls	Diaphragms	Connections	Options

Some combinations are not possible. Please check with your local supplier or pump configurator on [www.verderair.com](http://www.verderair.com).

Pump	Fluid Section Material		Air Section Material		Check Valve Material	
<b>VA 25HP</b>	<b>A</b>	Aluminum	<b>A</b>	Aluminum	<b>GE</b>	Geolast
	<b>S</b>	Stainless Steel			<b>SP</b>	Santoprene
					<b>SS</b>	Stainless Steel

Check Valve Balls		Diaphragm Material		Connections		Options	
<b>GE</b>	Geolast	<b>BN</b>	Buna-N	<b>TB</b>	Threaded BSP	<b>00</b>	Standard
<b>NW</b>	Polychloroprene Weighted	<b>NO</b>	Polychloroprene Overmolded	<b>TN</b>	Threaded NPT		
<b>SP</b>	Santoprene	<b>SP</b>	Santoprene				
<b>SS</b>	Stainless Steel	<b>TF</b>	PTFE/Santoprene Two-Piece				









## Approvals







Approvals	
All Models are certified to:	  II 2 GD Ex h IIC 66°C...135°C Gb Ex h IIIC T135°C Db







ATEX T-code rating is dependent on the temperature of the fluid being pumped. Fluid temperature is limited by the materials of the pump interior wetted parts. See **Technical Data** for the maximum fluid operating temperature for your specific pump model.

# Warnings

The following warnings are for the setup, use, grounding, maintenance, and repair of this equipment. The exclamation point symbol alerts you to a general warning and the hazard symbols refer to procedure-specific risks. When these symbols appear in the body of this manual or on warning labels, refer back to these Warnings. Product-specific hazard symbols and warnings not covered in this section may appear throughout the body of this manual where applicable.

 <h2 style="margin: 0;">WARNING</h2>	
     	<p><b>FIRE AND EXPLOSION HAZARD</b></p> <p>Flammable fumes, such as solvent and paint fumes, in <b>work area</b> can ignite or explode. To help prevent fire and explosion:</p> <ul style="list-style-type: none"> <li>• Use equipment only in well ventilated area.</li> <li>• Eliminate all ignition sources; such as pilot lights, cigarettes, portable electric lamps, and plastic drop cloths (potential static arc).</li> <li>• Keep work area free of debris, including solvent, rags and gasoline.</li> <li>• Do not plug or unplug power cords, or turn power or light switches on or off when flammable fumes are present.</li> <li>• Ground all equipment in the work area. See <b>Grounding</b> instructions.</li> <li>• Use only grounded hoses.</li> <li>• <b>Stop operation immediately</b> if static sparking occurs or you feel a shock. Do not use equipment until you identify and correct the problem.</li> <li>• Keep a working fire extinguisher in the work area.</li> <li>• Route exhaust away from all ignition sources. If diaphragm ruptures, fluid may be exhausted with air.</li> </ul>
 	<p><b>PRESSURIZED EQUIPMENT HAZARD</b></p> <p>Fluid from the equipment, leaks, or ruptured components can splash in the eyes or on skin and cause serious injury.</p> <ul style="list-style-type: none"> <li>• Follow the <b>Pressure Relief Procedure</b> when you stop spraying/dispensing and before cleaning, checking, or servicing equipment.</li> <li>• Tighten all fluid connections before operating the equipment.</li> <li>• Check hoses, tubes, and couplings daily. Replace worn or damaged parts immediately.</li> </ul>

 <h1 style="margin: 0;">WARNING</h1>	
 	<p><b>EQUIPMENT MISUSE HAZARD</b></p> <p>Misuse can cause death or serious injury.</p> <ul style="list-style-type: none"> <li>• Do not operate the unit when fatigued or under the influence of drugs or alcohol.</li> <li>• Do not exceed the maximum working pressure or temperature rating of the lowest rated system component. See <b>Technical Data</b> in all equipment manuals.</li> <li>• Use fluids and solvents that are compatible with equipment wetted parts. See <b>Technical Data</b> in all equipment manuals. Read fluid and solvent manufacturer’s warnings. For complete information about your material, request SDS from distributor or retailer.</li> <li>• Do not leave the work area while equipment is energized or under pressure.</li> <li>• Turn off all equipment and follow the <b>Pressure Relief Procedure</b> when equipment is not in use.</li> <li>• Check equipment daily. Repair or replace worn or damaged parts immediately with genuine manufacturer’s replacement parts only.</li> <li>• Do not alter or modify equipment. Alterations or modifications may void agency approvals and create safety hazards.</li> <li>• Make sure all equipment is rated and approved for the environment in which you are using it.</li> <li>• Use equipment only for its intended purpose. Call your distributor for information.</li> <li>• Route hoses and cables away from traffic areas, sharp edges, moving parts, and hot surfaces.</li> <li>• Do not kink or over bend hoses or use hoses to pull equipment.</li> <li>• Keep children and animals away from work area.</li> <li>• Comply with all applicable safety regulations.</li> </ul>
	<p><b>PRESSURIZED ALUMINUM PARTS HAZARD</b></p> <p>Use of fluids that are incompatible with aluminum in pressurized equipment can cause serious chemical reaction and equipment rupture. Failure to follow this warning can result in death, serious injury, or property damage.</p> <ul style="list-style-type: none"> <li>• Do not use 1,1,1-trichloroethane, methylene chloride, other halogenated hydrocarbon solvents or fluids containing such solvents.</li> <li>• Do not use chlorine bleach.</li> <li>• Many other fluids may contain chemicals that can react with aluminum. Contact your material supplier for compatibility.</li> </ul>
  	<p><b>THERMAL EXPANSION HAZARD</b></p> <p>Fluids subjected to heat in confined spaces, including hoses, can create a rapid rise in pressure due to the thermal expansion. Over-pressurization can result in equipment rupture and serious injury.</p> <ul style="list-style-type: none"> <li>• Open a valve to relieve the fluid expansion during heating.</li> <li>• Replace hoses proactively at regular intervals based on your operating conditions.</li> </ul>

 <h1 style="margin: 0;">WARNING</h1>	
 	<p><b>PLASTIC PARTS CLEANING SOLVENT HAZARD</b></p> <p>Many solvents can degrade plastic parts and cause them to fail, which could cause serious injury or property damage.</p> <ul style="list-style-type: none"> <li>• Use only compatible water-based solvents to clean plastic structural or pressure-containing parts.</li> <li>• See <b>Technical Data</b> in this and all other equipment instruction manuals. Read fluid and solvent manufacturer's SDSs and recommendations.</li> </ul>
 	<p><b>TOXIC FLUID OR FUMES HAZARD</b></p> <p>Toxic fluids or fumes can cause serious injury or death if splashed in the eyes or on skin, inhaled, or swallowed.</p> <ul style="list-style-type: none"> <li>• Read SDSs to know the specific hazards of the fluids you are using.</li> <li>• Route exhaust away from work area. If diaphragm ruptures, fluid may be exhausted into the air.</li> <li>• Store hazardous fluid in approved containers, and dispose of it according to applicable guidelines.</li> </ul>
	<p><b>BURN HAZARD</b></p> <p>Equipment surfaces and fluid that's heated can become very hot during operation. To avoid severe burns:</p> <ul style="list-style-type: none"> <li>• Do not touch hot fluid or equipment.</li> </ul>
	<p><b>PERSONAL PROTECTIVE EQUIPMENT</b></p> <p>Wear appropriate protective equipment when in the work area to help prevent serious injury, including eye injury, hearing loss, inhalation of toxic fumes, and burns. This protective equipment includes but is not limited to:</p> <ul style="list-style-type: none"> <li>• Protective eyewear, and hearing protection.</li> <li>• Respirators, protective clothing, and gloves as recommended by the fluid and solvent manufacturer.</li> </ul>

# Troubleshooting

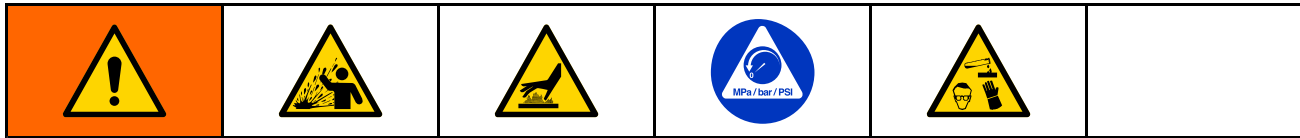

Problem	Cause	Solution
Pump cycles but will not prime.	Pump is running too fast, causing cavitation before prime.	Reduce air inlet pressure or restrict inlet air with a needle valve.
	Check valve ball severely worn or wedged in seat or manifold.	Replace ball and seat.
	Seat severely worn.	Replace ball and seat.
	Outlet or inlet clogged.	Unclog.
	Inlet or outlet valve closed.	Open.
	Inlet fittings or manifolds loose.	Tighten.
	Manifold o-rings damaged.	Replace o-rings.
Pump cycles at stall or fails to hold pressure at stall.	Worn check valve balls, seats, or o-rings.	Replace.
Pump will not cycle, or cycles once and stops.	Air valve is stuck or dirty.	Disassemble and clean air valve. Use filtered air.
	Check valve ball severely worn and wedged in seat or manifold.	Replace ball and seat.
	Pilot valve worn, damaged, or plugged.	Replace pilot valve.
	Air valve gasket damaged.	Replace gasket.
	Dispensing valve clogged.	Relieve pressure and clear valve.
	High/Low valve shift lever is not fully seated into the High or Low position.	Shift lever all the way into either High or Low position.
Pump operates erratically.	Clogged suction line.	Inspect; clear.
	Sticky or leaking check valve balls.	Clean or replace.
	Diaphragm ruptured.	Replace.
	Restricted exhaust.	Remove restriction.
	Pilot valves damaged or worn.	Replace pilot valves.
	Air valve damaged.	Replace air valve.
	Air valve gasket damaged.	Replace air valve gasket.
	Air supply erratic.	Repair air supply.
Exhaust muffler icing.	Use drier air supply.	



Problem	Cause	Solution
Air bubbles in fluid.	Suction line is loose.	Tighten.
	Diaphragm ruptured.	Replace.
	Loose manifolds, damaged seats or o-rings.	Tighten manifold bolts or replace seats or o-rings.
	Pump cavitation.	Reduce pump speed or suction lift.
	Loose diaphragm shaft bolt.	Tighten.
Exhaust air contains fluid being pumped.	Diaphragm ruptured.	Replace.
	Loose diaphragm shaft bolt.	Tighten or replace.
Moisture in exhaust air.	High inlet air humidity.	Use drier air supply.
Pump exhausts excessive air at stall.	Worn air valve cup or plate.	Replace cup and plate.
	Damaged air valve gasket.	Replace gasket.
	Damaged pilot valve.	Replace pilot valves.
	Worn shaft seals or bearings.	Replace shaft seals or bearings.
Pump leaks air externally.	Air valve or fluid cover screws loose.	Tighten.
	Diaphragm damaged.	Replace diaphragm.
	Air valve gasket damaged.	Replace gasket.
	High/Low valve shift lever is not fully seated into the High or Low position.	Shift the lever all the way into either High or Low position.
Pump leaks fluid externally from joints.	Loose manifold screws or fluid cover screws.	Tighten manifold screws or fluid cover screws.
	Manifold o-rings worn out.	Replace o-rings.
Pump will operate in the Low pressure setting, but will not operate in the High pressure setting.	The hoses for the High/Low valve are not installed correctly.	Install hoses exactly as shown in the <a href="#">Pressure Relief Procedure, page 10</a> .

# Repair

## Pressure Relief Procedure



Follow the Pressure Relief Procedure whenever you see this symbol.



This equipment stays pressurized until pressure is relieved manually. To help prevent serious injury from pressurized fluid, such as splashing in the eyes or on skin, follow the Pressure Relief Procedure when you stop pumping and before you clean, check, or service the equipment.

1. Shut off the air supply to the pump.
2. Open the dispensing valve, if used.
3. Shift the High/Low pressure lever back and forth two times. Leave the lever in the "Low" position as shown.

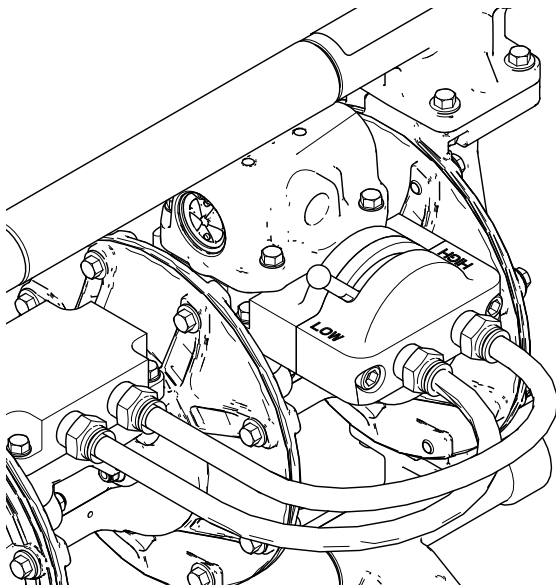

Figure 1 High/Low Pressure Lever

4. Open the fluid drain valve (installed on the system) to relieve all fluid pressure. Have a container ready to catch the drainage.

## Replace Complete Air Valve

Follow these instructions to install Air Valve Replacement 859.0392.

1. Stop the pump. Follow the **Pressure Relief Procedure** in the previous section.
2. Disconnect the main air line.
3. Remove four screws (217). Remove the air valve (212). Remove the six o-rings (208, 209, and 210).
4. To repair the air valve, go to **Disassemble the Air Valve**, step 2, in the next section. To install a replacement air valve, continue with step 5.
5. Install the new o-rings (208, 209, and 210) on the High/Low manifold, then attach the air valve. Apply thread lubricant and torque screws (217) to 9 N•m (80 in-lb).
6. Reconnect the main air line.

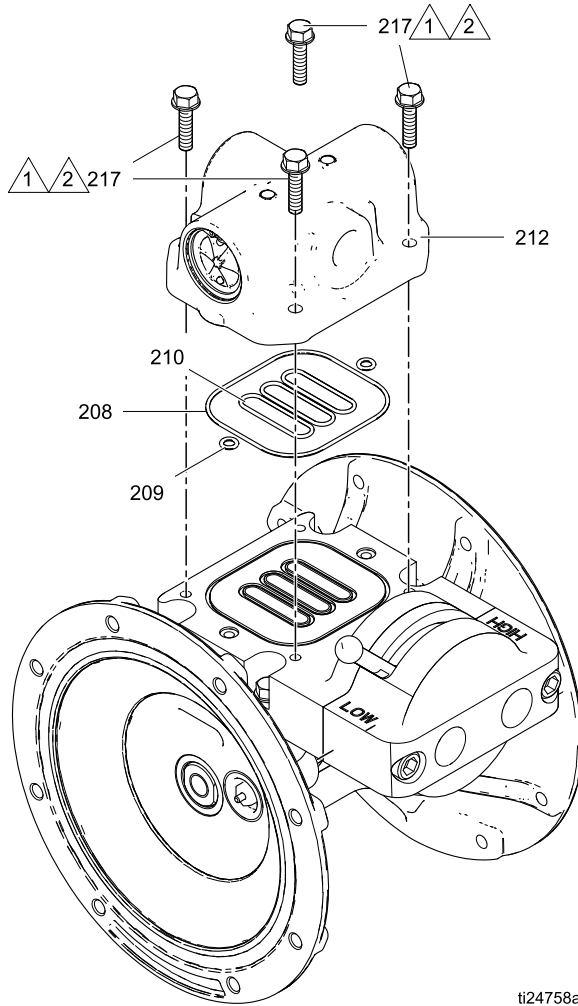

Apply thread lubricant to threads before assembly.



Torque screws to 9 N•m (80 in-lb).

ti24758a

## Replace Seals or Rebuild Air Valve

Follow these instructions to service the air valve with one of the available repair kits. Air Valve Seal Kit parts are marked with a †. Air Valve Repair Kit parts are marked with a ♦. Air Valve End Cap Kit parts are marked with a ‡. Kit 859.0385 also is available to replace the 6 o-rings between the air valve and the High/Low manifold.

### Disassemble the Air Valve

1. Perform steps 1-3 under [Replace Complete Air Valve, page 10](#).
2. Use a T8 Torx screwdriver to remove two screws (309). Remove the valve plate (305), cup assembly (312-314), spring (311), and detent assembly (303).
3. Pull the cup (313) off of the base (312). Remove the o-ring (314) from the cup.
4. Remove the retaining ring (310) from each end of the air valve. Use the piston (302) to push the end cap (307) out of one end. Remove the u-cup seal (308) from the piston. Pull the piston out of the end and remove the other u-cup seal (308). Remove the other end cap (307) and the end cap o-rings (306).
5. Remove the detent cam (304) from the air valve housing (301).

### Reassemble the Air Valve

**NOTE:** Apply lithium-based grease when instructed to grease. Order PN 819.0184.

1. Use all parts in the repair kits. Clean other parts and inspect for damage. Replace as needed.
2. Grease the detent cam (304♦) and install into housing (301).
3. Grease the u-cups (308♦†) and install on the piston with lips facing toward the center of the piston.

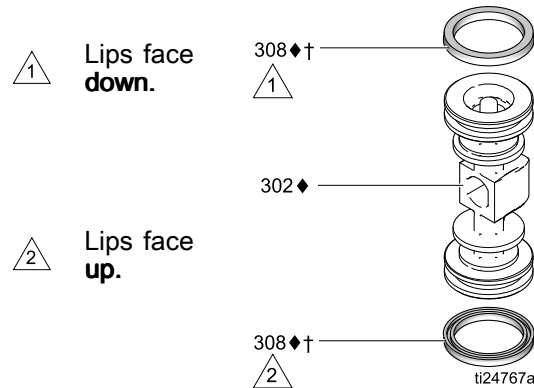

4. Grease both ends of the piston (302♦) and the housing bore. Install the piston in the housing (301), with the flat side toward the cup (313♦). Be careful not to tear u-cups (308♦†) when sliding piston into housing.
5. Grease new o-rings (306♦†‡) and install on the end caps (307‡). Install the end caps into the housing.
6. Install a retaining ring (310‡) on each end to hold end caps in place.

- Grease and install the detent assembly (303♦) into the piston. Install the o-ring (314♦) on the cup (313♦). Apply a light film of grease to the outside surface of the o-ring and the inside mating surface of the base (312♦). Orient the end of the base that has a magnet toward the end of the cup that has the larger cutout. Engage the opposite end of the parts. Leave the end with the magnet free. Tilt the base toward the cup and fully engage the parts, using care so that the o-ring remains in place. Install the spring (311♦) onto the protrusion on the cup. Align the magnet in the base with the air inlet and install the cup assembly.

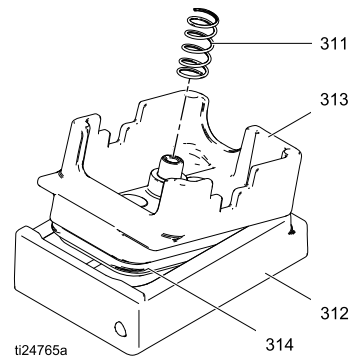

- Grease the cup side and install the valve plate (305♦). Align the small hole in the plate with the air inlet. Tighten the screws (309♦†) to hold it in place.
- Follow steps 5–6 under [Replace Complete Air Valve, page 10](#) to replace the seals and reattach the air valve.

- 1 Apply lithium-based grease.
- 2 U-cup lips must face piston.
- 3 Apply lithium-based grease to contact surface.
- 4 Air inlet.

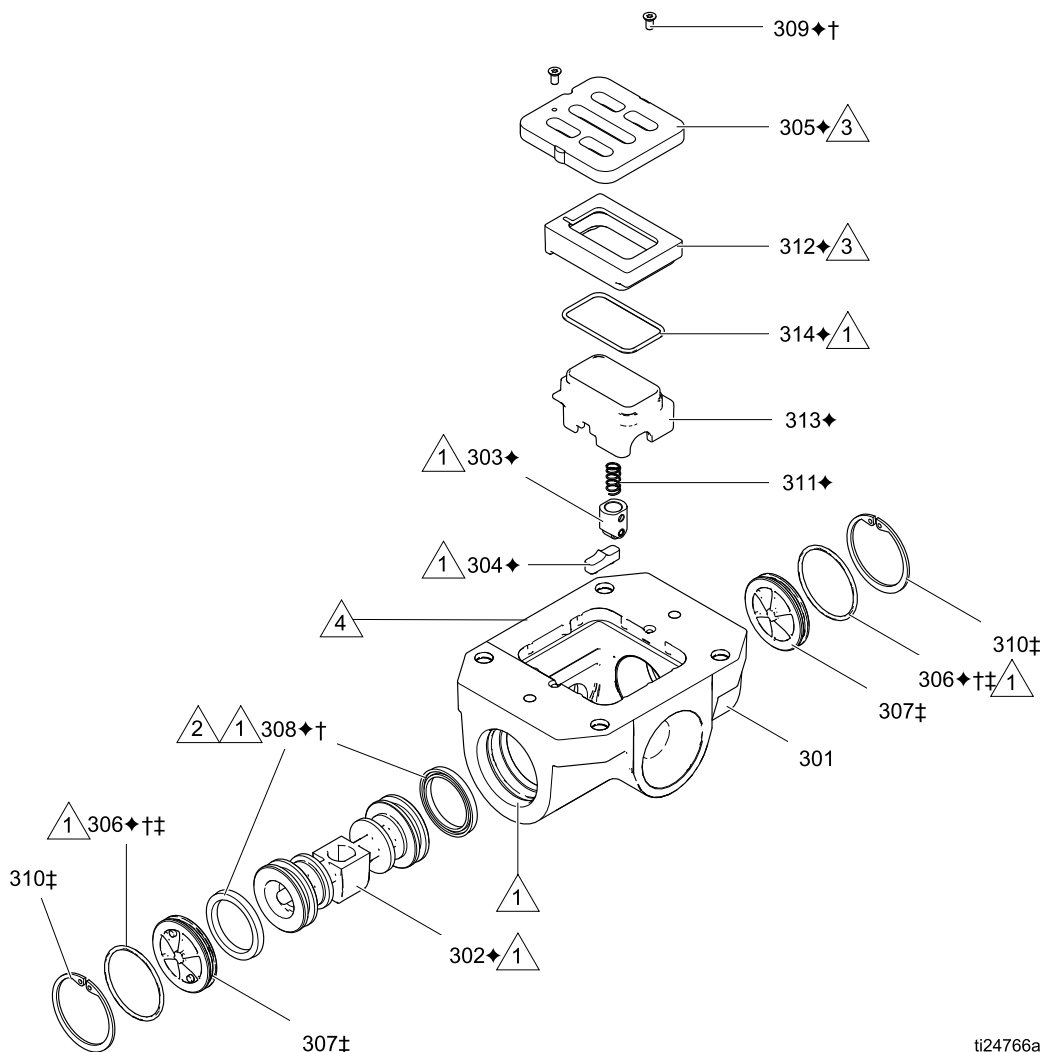

## Replace Complete High/Low Valve

1. Stop the pump. Follow the [Pressure Relief Procedure, page 10](#).
2. Disconnect the main air line. Release the quick disconnect fittings to remove the air manifold hoses (108).
3. To repair the High/Low valve, go to **Disassemble the High/Low Valve**, step 2, in the next section. To install a replacement air valve, continue with step 4.
4. Remove four screws (217). Remove the air valve (212). Remove the six o-rings (208, 209, and 210).
5. Remove four screws (217). Remove the High/Low valve (211) and gasket (213).
6. Align the new gasket (213) on the primary center section, then attach the new High/Low valve (211). Apply thread lubricant and torque screws (217) to 9 N•m (80 in-lb).
7. Install the new o-rings (208, 209, and 210) on the High/Low manifold, then attach the air valve.
8. Reconnect the main air line and the air manifold hoses (108).

 Apply thread lubricant to threads before assembly.

 Torque screws to 9 N•m (80 in-lb).

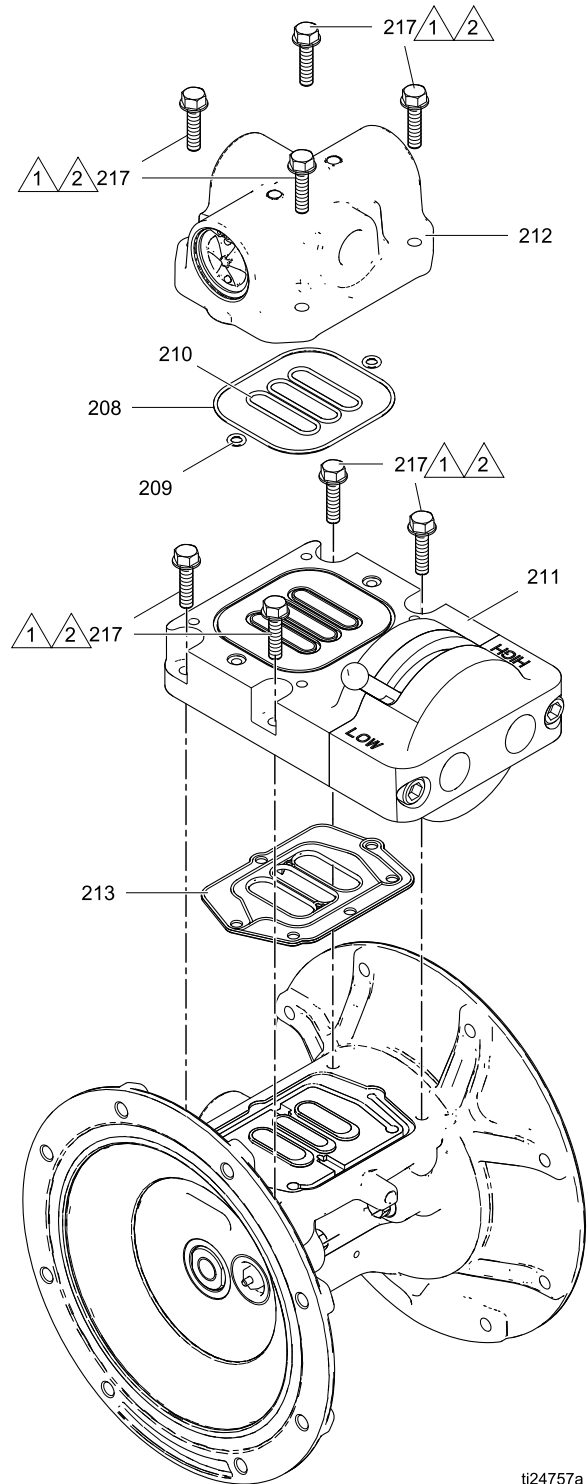

ti24757a

## Replace Seals or Rebuild the High/Low Valve

Follow these instructions to service the High/Low valve. High/Low Valve Seal Kit 859.0382 is available to replace o-rings 402 and 405. Kit 859.0385 also is available to replace the 6 o-rings between the air valve and the High/Low manifold. Kit 859.0383 is available to replace the spool (404).

### Disassemble the High/Low Valve

1. Follow steps 1 and 2 under [Replace Complete High/Low Valve, page 14](#).
2. Use a 5/16 in Allen wrench to remove two screws (407).
3. Remove the High/Low valve (406). Unscrew the handle (403) from the spool (404), then remove the spool. Use an o-ring pick to remove all o-rings (402 and 405) from the spool.

**NOTE:** The High/Low manifold block does not have to be removed from the primary center section.

### Reassemble the High/Low Valve

**NOTE:** Apply lithium-based grease when instructed to grease.

1. Use all parts in the seal kit. Clean other parts and inspect for damage. Replace as needed.
2. Grease two o-rings (402) and install them in the manifold block (401).
3. Grease and install three o-rings (402 and 405) on the spool (404).

4. Grease the outside edge, then install the spool (404) in the High/Low valve (406). Install the lever (403).
5. Use two screws (407) to reattach the High/Low valve. Torque to 38–41 N•m (340–360 in-lb).
6. Reconnect the main air line and the air manifold hoses (108).

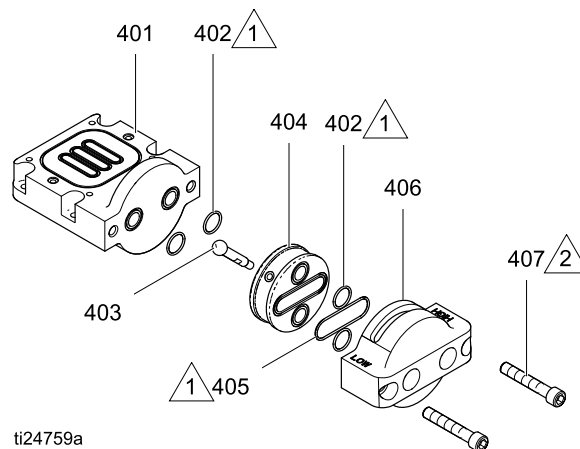

ti24759a



Apply lithium-based grease.



Torque to 38–41 N•m (340–360 in-lb).

## Check Valve Repair

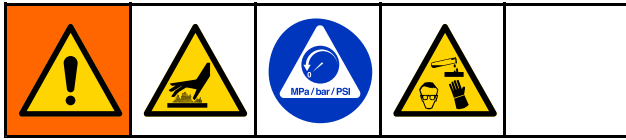

**NOTE:** Kits are available for new check valve balls and seats. See Seats and Check Balls, page 38, to order kits in the material(s) desired. O-ring and fastener kits also are available, page 25.

**NOTE:** To ensure proper seating of the check balls, always replace the seats when replacing the balls. Also, replace the o-rings every time the manifold is removed.

### Disassemble the Check Valve

1. Follow the [Pressure Relief Procedure, page 10](#). Disconnect all hoses.
2. Remove the pump from its mounting.
3. Use a 10 mm socket wrench to remove the manifold fasteners (5), then remove the outlet manifold (3).
4. Remove the o-rings (9), seats (7), and balls (8).
5. Remove the nuts (27).
6. Turn the pump over and remove the inlet manifold (4).
7. Remove the o-rings (9), seats (7), and balls (8).

### Reassemble the Check Valve

1. Clean all parts and inspect for wear or damage. Replace parts as needed.
2. Reassemble in the reverse order, following all notes in the illustration. Put the inlet manifold on first. Be sure the ball checks (7-9) and manifolds (3, 4) are assembled **exactly** as shown. The ball must seat on the chamfered side of the seat. The arrows (A) on the fluid covers (2) **must** point toward the outlet manifold (3).

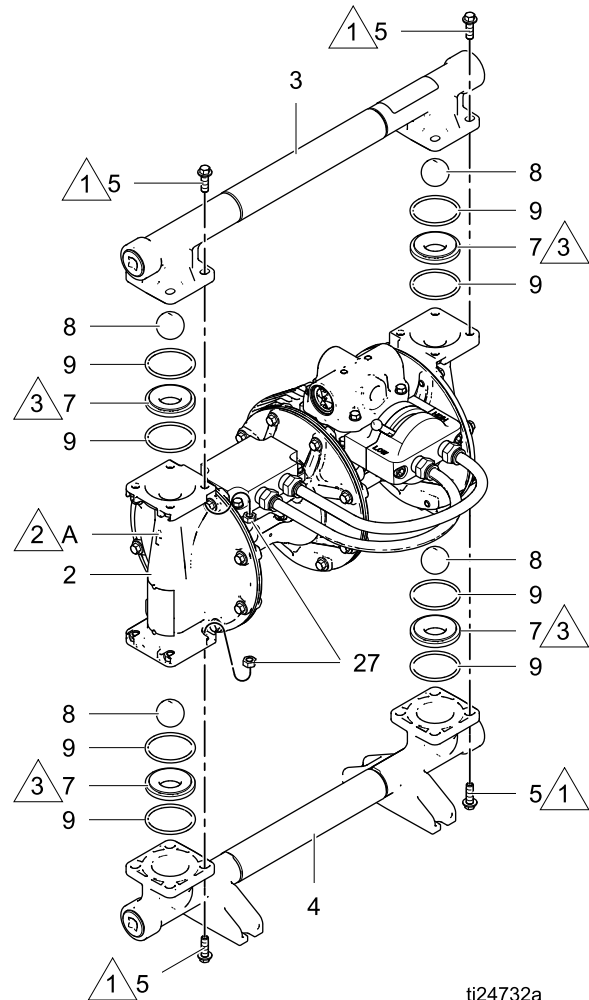
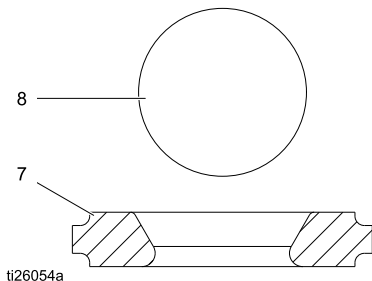

Figure 2 Check valve assembly

- 1 Torque to 11.3 N•m (100 in-lb). Follow torque sequence. See [Torque Instructions, page 22](#).
- 2 Arrow (A) must point toward the outlet manifold.
- 3 The chamfered side of the seat must face the ball.





## Diaphragm and Center Section Repair

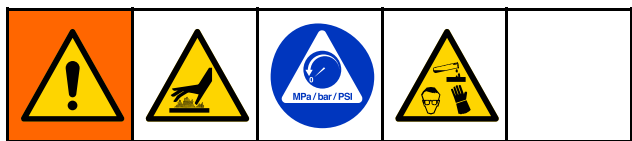

**NOTE:** See Diaphragms, pages 39–40, for replacement diaphragm kits. Center Rebuild Kit 859.0379 also is available. Parts included in the Center Rebuild Kit are marked with an \*. For best results, use all kit parts.

### Disassemble the Fluid Diaphragms

1. Follow the [Pressure Relief Procedure, page 10](#).
2. Remove the manifolds and disassemble the ball check valves as explained in [Check Valve Repair, page 16](#). Remove the muffler (18).
3. Use a 10 mm socket wrench to remove the fluid cover screws (5), then remove the fluid covers (2).
4. **Bolt-Through Diaphragms:** Use a 15 mm socket wrench to remove the diaphragm shaft bolt (14) on one side of the pump. If the shaft (206) remains attached to the bolt, use a wrench on the flats of the shaft to remove it. Then, remove all parts of that diaphragm assembly.  
**Overmolded Diaphragms:** The diaphragm (12) on one side of the pump will screw off by hand. The diaphragm setscrew should remain attached to the diaphragm. If the shaft (206) remains attached to the diaphragm setscrew, use a wrench on the flats of the shaft to remove it. Remove the air side diaphragm plate (11).
5. Repeat for the other diaphragm.

### Disassemble the Center Section

1. Use a 10 mm socket wrench to remove the screws (5), then separate the primary air module (101) from the secondary air module (102).
2. Remove the diaphragm (109), the air plates (103 and 105), and the set screw (104).
3. Inspect the diaphragm shafts (206) for wear or scratches. If damaged, inspect the bearings (203) in place. If they are damaged, use a bearing puller to remove them. **NOTE: Do not remove undamaged bearings.**

4. Use an o-ring pick to remove the u-cup packings (202) from the primary air module and the secondary air module. Bearings (203) can remain in place.
5. If necessary, use a box end wrench to remove the pilot valves (205, primary air module) or the secondary pilot plugs (220, secondary air module).
6. Remove the pilot valve cartridges only if necessary due to a known or suspected problem. **After removing pilot valves (primary side) or secondary pilot plugs (secondary side),** use a hex to remove the cartridges (204), then remove cartridge o-rings (219). If stripped, cross two screwdrivers in the shape of an X. Insert the blades into the area around the 10 mm hex. Revolve the blades against each other while holding the tips against the outer area of the recess to unscrew the cartridge. **NOTE: Do not remove undamaged pilot valve cartridges.**

### Reassemble the Center Section

Follow all notes in the illustrations. These notes contain **important** information.

**NOTE:** Apply lithium-based grease whenever instructed to grease.

1. Clean all parts and inspect for wear or damage. Replace parts as needed.  
**NOTE:** Follow Steps 2–5 for both the **Primary Air Module** and the **Secondary Air Module**.
2. If removed, grease and install the new pilot valve cartridges (204\*) and cartridge o-rings (219\*). Screw in until seated.  
**NOTE:** Cartridges (204\*) must be installed before pilot valves (205\*) or secondary pilot plugs (220\*).
3. Grease and install the pilot valves (205\*, primary side) or secondary pilot plugs (220\*, secondary side). Torque to 2–3 N•m (20–25 in-lb) at 100 rpm maximum. Do not overtorque.
4. Grease and install the diaphragm shaft u-cup packings (202\*) so the lips face out of the housing.
5. If removed, insert the new bearings (203\*) into the primary air module and/or the secondary air module. Use a press or a block and rubber mallet to press-fit the bearing so it is flush with the surface of the module.

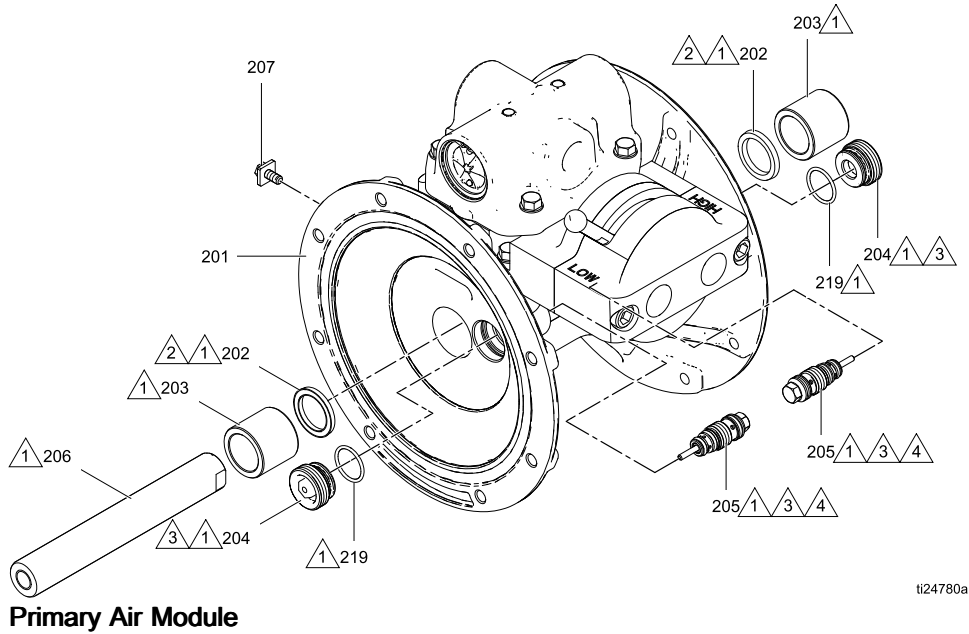

**Primary Air Module**

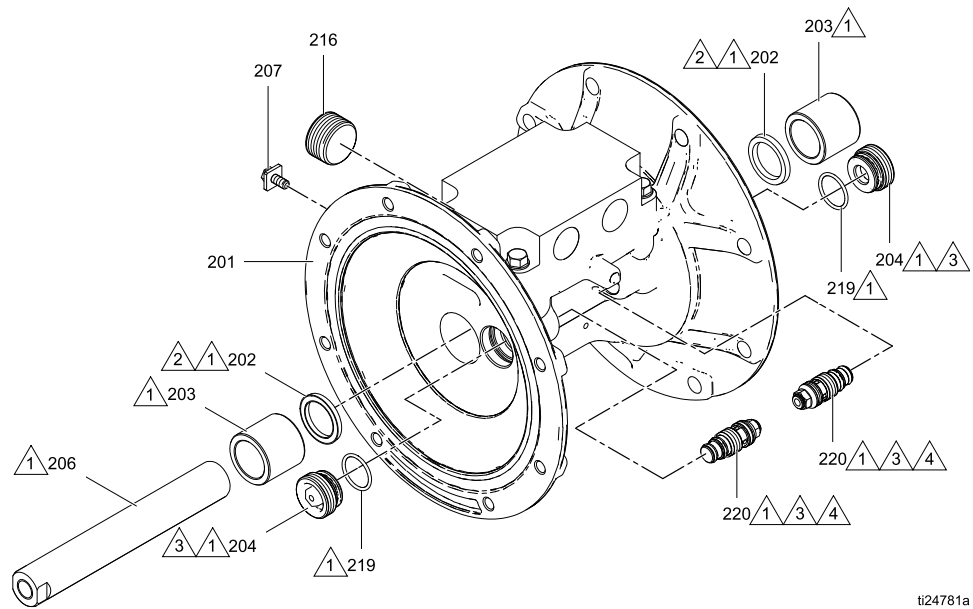

**Secondary Air Module**



Apply lithium based grease.



Lips must face out of housing.



Cartridges (204) must be installed before pilot valves (205) or secondary pilot plugs (220).



Torque to 2-3 N•m (20-25 in.-lb).

## Reassemble the Fluid Diaphragms

Follow all notes in the illustrations. These notes contain **important** information.

**NOTE:** Apply lithium-based grease whenever instructed to grease.

1. Assemble the center diaphragm section:
  - a. Assemble the primary side air plate (105\*), the center diaphragm (109\*), and the secondary side air plate (103\*) on the set screw (104\*).
  - b. **IMPORTANT:** The marked "Air" side of the center diaphragm **must** face the primary air side plate and the primary air module.
  - c. Install a shaft (206\*) on each end.
  - d. Tighten until assembly is fully seated and parts do not freely rotate.

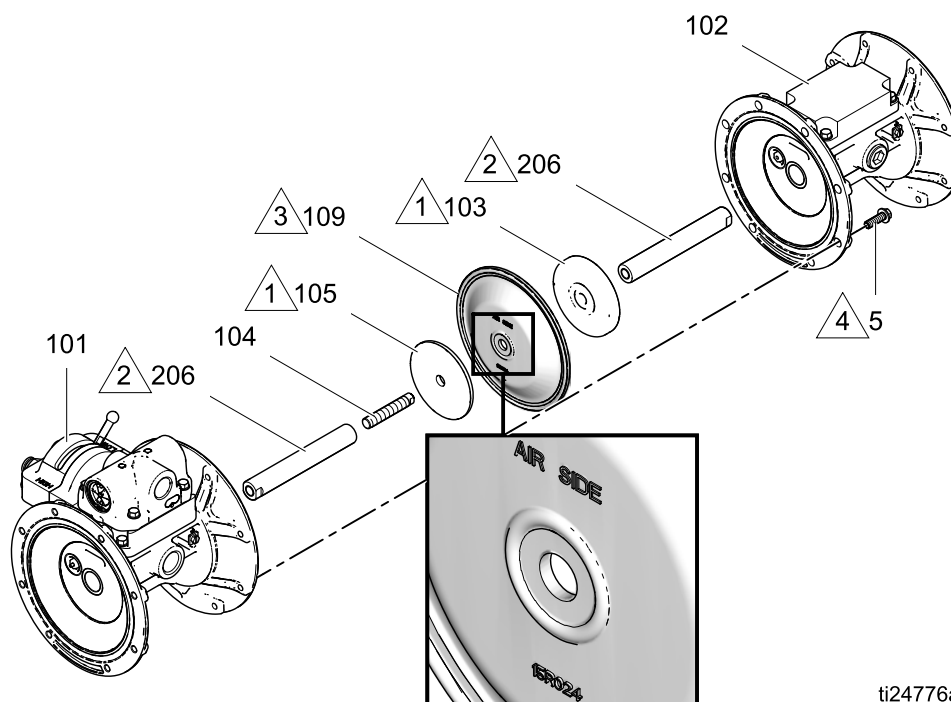

1. Rounded side faces diaphragm.
2. Apply lithium based grease.
3. AIR SIDE markings on center diaphragm must face the primary air module.
4. Torque to 11.3 N•m (100 in-lb).

2. Grease the shaft u-cups (202\*) and the length of both diaphragm shafts (206\*). Slide the shaft on the primary side (closest to air plate 105\*) into the primary air module.
3. Slide the secondary air module onto the secondary side shaft (closest to air plate 103\*).
4. Install the diaphragm joint bolts (5). Torque to 11.3 N•m (100 in-lb). Follow [Torque Instructions, page 22](#).

### 5. Bolt-Through Diaphragms



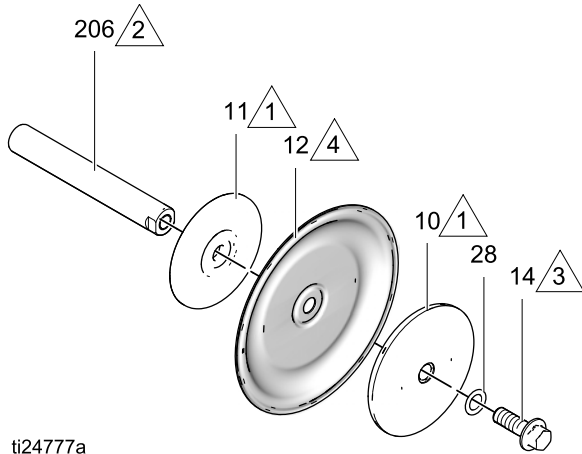

- Assemble the o-ring (28), the fluid side diaphragm plate (10), the diaphragm (12), and the air side diaphragm plate (11), on a diaphragm shaft bolt (14), exactly as shown.
- Apply medium-strength (blue) thread locker to the threads of the bolt (14). Screw the assembly into the shaft of the secondary air module hand-tight.
- Repeat for the other diaphragm assembly and install on the primary air module.
- Torque both bolts to 20–25 ft-lb (27–34 N•m) at 100 rpm maximum. Do not over-torque.

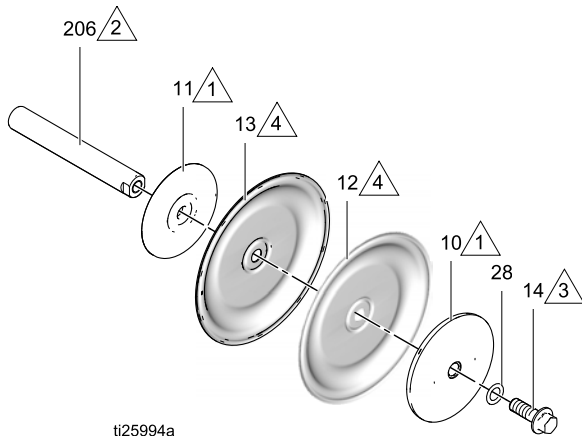

ti24777a



ti25994a



-  Rounded side faces diaphragm.
-  Apply lithium based grease.
-  Apply primer and medium-strength (blue) thread locker. Torque to 27–34 N•m (20–25 ft-lb) at 100 rpm maximum.
-  AIR SIDE markings on fluid diaphragms must face center housing.

### 6. Overmolded Diaphragms

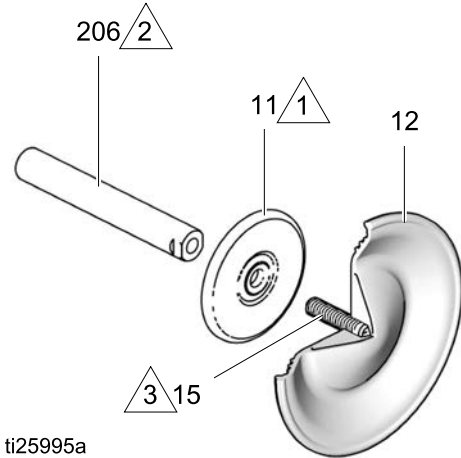
- If the diaphragm setscrew comes loose or is replaced, apply permanent (red) thread sealant to the diaphragm-side threads. Screw into the diaphragm until tight.
- Assemble the air side plate onto the diaphragm. The rounded side of the plate must face the diaphragm.



ti25995a

-  Rounded side faces diaphragm.
-  Apply lithium based grease.
-  If screw comes loose or is replaced, apply permanent (red) thread locker to the diaphragm side threads. Apply primer and medium-strength (blue) thread locker to the shaft side threads.

- Apply medium-strength (blue) thread locker to the threads of the diaphragm assembly. Screw the assembly into the shaft of the secondary air module as tight as possible by hand.
- Repeat for the other diaphragm assembly and install it on the primary air module.

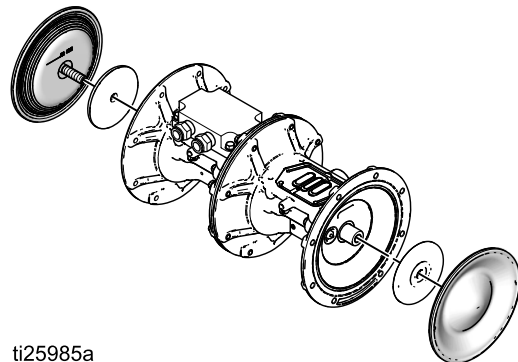

ti25985a

7. Reattach the secondary side fluid cover (2). The arrow must point toward the air valve. See [Torque Instructions, page 22](#).

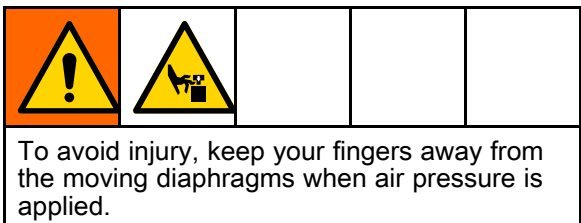

8. To ensure proper seating and extend diaphragm life, apply air pressure to the pump prior to attaching the fluid cover on the primary air module.

**NOTE:** Be sure the High/Low valve is attached. See [Replace Complete High/Low Valve, page 14](#).

- a. Place the supplied tool on top of the air valve gasket (213). Arrows (A) must face toward the fluid cover that is already attached.

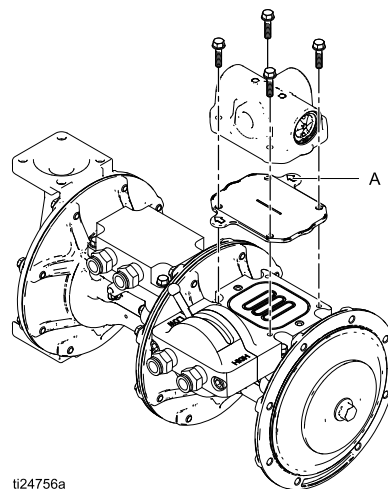

ti24756a

Figure 3 Fluid cover tool

- b. Reattach the air valve.
- c. Supply a minimum of 0.7 to 1.4 bar (0.07–0.14 MPa, 10–20 psi) air pressure to the air valve. Shop air may be used. The diaphragm will shift so the second fluid cover will seat properly. Keep air pressure on until the second fluid cover is attached.
- d. Attach the second fluid cover (2). See [Torque Instructions, page 22](#).
- e. Remove the air valve and the tool. Verify that the gasket (213), is in place, and reattach the air valve. See [Torque Instructions, page 22](#).

**NOTE:** These steps must be followed anytime the fluid covers are removed.

- f. Reassemble the ball check valves and manifolds as explained in [Check Valve Repair, page 16](#).
- g. If not already attached, reinstall the air lines and the muffler.

# Torque Instructions

**NOTE:** All fasteners for the fluid covers, center diaphragm joint, and manifolds have a thread-locking adhesive patch applied to the threads. If this patch is excessively worn, the fasteners may loosen during operation. Replace screws with new ones or apply medium-strength (blue) Loctite or equivalent to the threads.

If fluid cover, center diaphragm joint, or manifold fasteners have been loosened, it is important to torque them using the following procedure to improve sealing.

**NOTE:** Always completely torque the fluid covers and the center diaphragm joint before torquing manifolds.

Start all fluid cover or center diaphragm joint screws a few turns. Then turn down each screw just until head contacts cover. Then turn each screw by 1/2 turn or less working in a crisscross pattern to specified torque. Repeat for manifolds.

**Fluid cover, center diaphragm joint, and manifold fasteners:** 11.3 N•m (100 in-lb)

Lubricate air valve fasteners prior to reassembly to prevent galling. Retorque the air valve fasteners (V) in a crisscross pattern to specified torque.

**Air valve fasteners:** 9.0 N•m (80 in-lb)

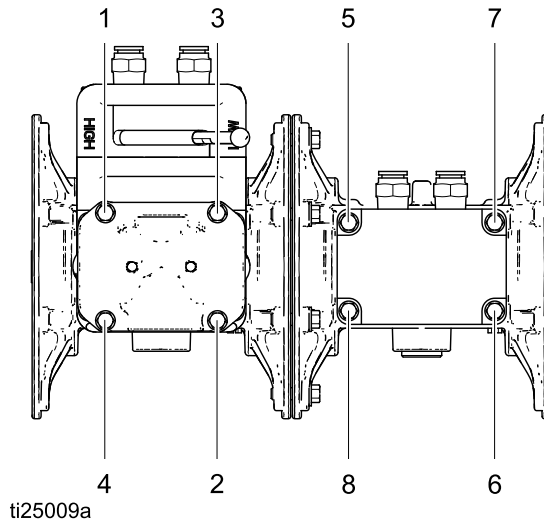

**Air Valve Fasteners**

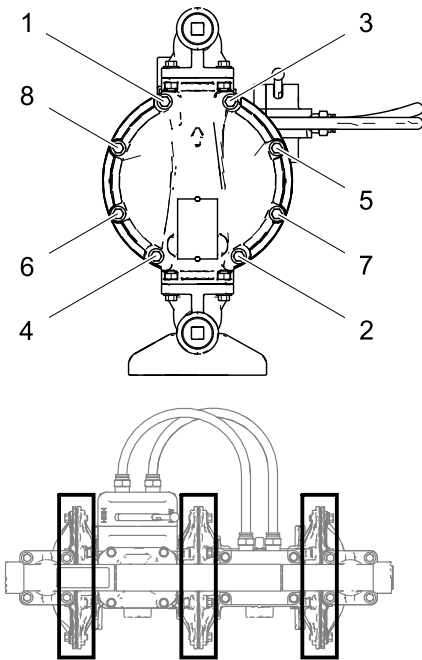

**Fluid Covers and Center Diaphragm Joint**

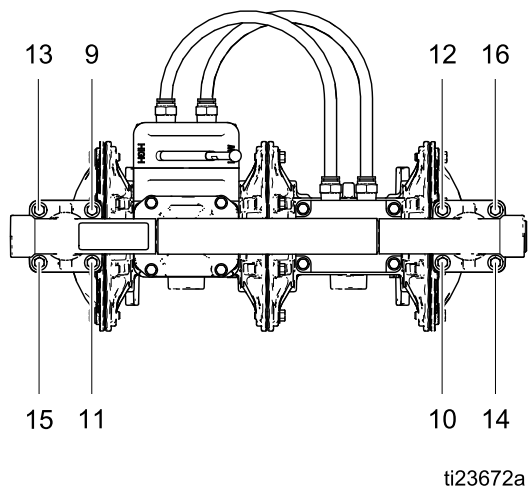

**Manifolds**

# Parts

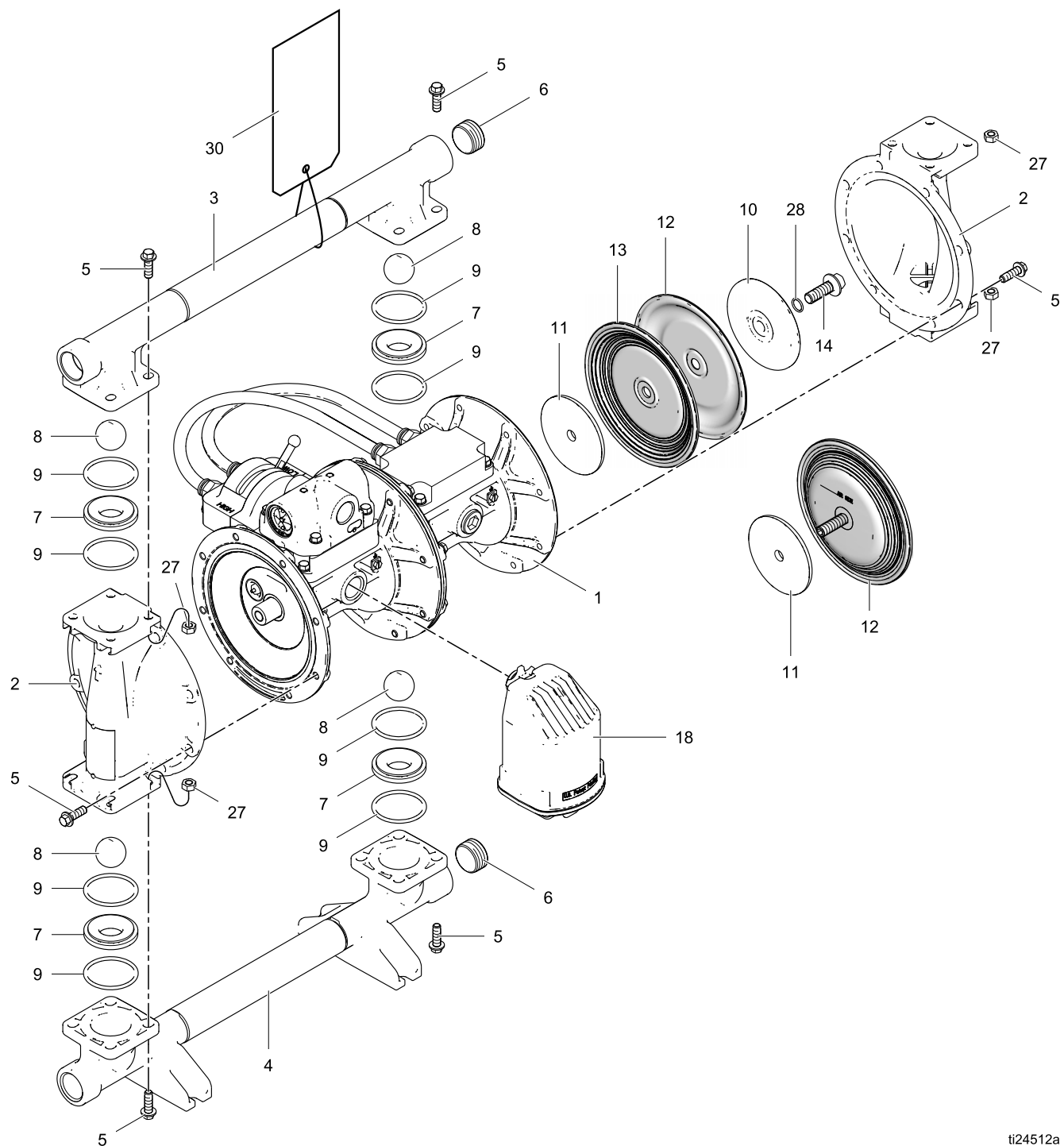

ti24512a

## Parts/Kits Quick Reference

Use this table as a quick reference for parts/kits. Go to the pages indicated in the table for a full description of kit contents.

Ref.	Part/Kit	Description	Qty.
1	— — —	AIR SECTION; Aluminum, not sold separately. <i>See page 26.</i>	1
2	859.0394	COVER, fluid, kit; stainless steel, <i>see page 26</i>	2
3		MANIFOLD, outlet, kit; <i>see page 24</i>	1
	859.0371	Aluminum, npt	
	859.0372	Aluminum, bspt	
	859.0375	Stainless steel, npt	
	859.0376	Stainless steel, bspt	
4		MANIFOLD, inlet, kit; <i>see page 24</i>	1
	859.0373	Aluminum, npt	
	859.0374	Aluminum, bspt	
	859.0377	Stainless steel, npt	
	859.0378	Stainless steel, bspt	
5		FASTENERS, <i>see page 25</i>	
	859.0393	BOLT, M8 x 1.25 x 25 mm, for aluminum manifolds, includes nuts, package of 8	2
	859.0084	BOLT, M8 x 1.25 x 20 mm, for stainless steel manifolds, includes nuts, package of 8	2
	859.0033	BOLT, M8 x 1.25 x 25 mm, for fluid covers and bolting center sections together, package of 8	3
6		PLUG, Manifold, Kit; used only on aluminum manifolds; includes 6	1
	859.0105	For npt manifolds	
	859.0106	For bsp manifolds	
7		SEATS 4-pack, includes 8 o-rings, <i>see page 38</i>	1
	859.0012	Geolast	
	859.0015	Santoprene	
	859.0016	Stainless steel	

Ref.	Part/Kit	Description	Qty.
8		BALLS, valve, check; 4-pack; Includes 8 o-rings, <i>see page 38</i>	1
	859.0020	Geolast	
	859.0023	Polychloroprene with SST core	
	859.0025	Santoprene	
	859.0026	Stainless Steel	
9	859.0034	O-RING, seat; 8-pack, <i>see page 25</i>	1
10	— — —	PLATE, fluid side diaphragm; included in Air and Fluid Plate Kit, <i>see page 40</i>	2
11	— — —	PLATE, air side diaphragm; included in Air and Fluid Plate Kit; <i>see page 40</i>	2
12		DIAPHRAGM, kit; 2-pack <i>see page 39</i>	1
	859.0001	Buna-N Bolt-Through	
	859.0004	Polychloroprene Overmolded	
	859.0414	PTFE/Santoprene Two Piece Bolt Through	
	859.0007	Santoprene	
13	— — —	DIAPHRAGM, backup, Santoprene, included in Kit	2
14	819.4482	BOLT, M12-1.75 x 35 mm, <i>for bolt-through diaphragms, includes o-ring, ref 28</i>	2
18	859.0238	MUFFLER, kit; includes o-ring and mounting hardware	1
19	819.4313▲	LABEL, warning	1
27	— — —	NUT, included with Ref. 5, in packages of 8	2
28	— — —	O-RING, included in diaphragm kits	2
30	859.0398▲	TAG, warning, torque instructions	1
35	819.4434▲	LABEL, warning, multilingual	1

▲ Replacement Warning labels, signs, tags, and cards are available at no cost.

— — — These parts are not sold separately.



## Fluid Section

### Sample Configuration Number

Pump Model	Fluid Section	Air Section	Seats	Balls	Diaphragms	Connections	Options
VA 25HP	<b>A</b>	A	SS	SP	SP	<b>TB</b>	00

### Aluminum Outlet Manifold Kits

<b>A...TN</b> (npt)	859.0371
<b>A...TB</b> (bsp)	859.0372

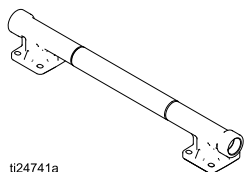

ti24741a

Kits include:

- 1 outlet manifold (3)
- 1 pipe plug (6)
- 4 o-rings(9), PTFE
- 1 warning label

Aluminum Inlet Manifold Kits	
<b>A...TN</b> (npt)	859.0373
<b>A...TB</b> (bsp)	859.0374

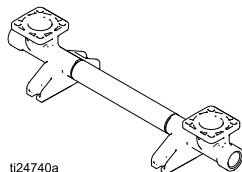

ti24740a

Kits include:

- 1 inlet manifold (4)
- 1 pipe plug (6)
- 4 o-rings (9), PTFE

Stainless Steel Outlet Manifold Kits	
<b>S...TN</b> (npt)	859.0375
<b>S...TB</b> (bsp)	859.0376

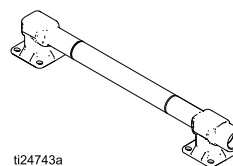

ti24743a

Kits include:

- 1 outlet manifold (3)
- 4 o-rings (9), PTFE
- 1 warning label

Stainless Steel Inlet Manifold Kits	
<b>S...TN</b> (npt)	859.0377
<b>S...TB</b> (bsp)	859.0378

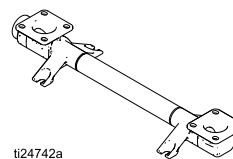

ti24742a

Kits include:

- 1 inlet manifold (4)
- 4 o-rings (9), PTFE

Parts

Fluid Cover Kit	
All Models	859.0394

Kits include:

- 1 fluid cover (2)
- 4 o-rings (9), PTFE

Manifold O-Ring Kits	
All Models	859.0034

Kits include:

- 8 o-rings (9), PTFE

Fastener Kits	
A	859.0393
S	859.0084
All Models	Order Kit 859.0033 for fluid covers and bolting the two air modules together, includes 8 bolts

Kits include:

- 8 screws, (5)
- 8 nuts (27, Kits 859.0393 and 859.0084)

# Air Section

## Sample Configuration Number

Pump Model	Fluid Section	Air Section	Seats	Balls	Diaphragms	Connections	Options
VA 25HP	A	<b>A</b>	SS	SP	SP	TB	00

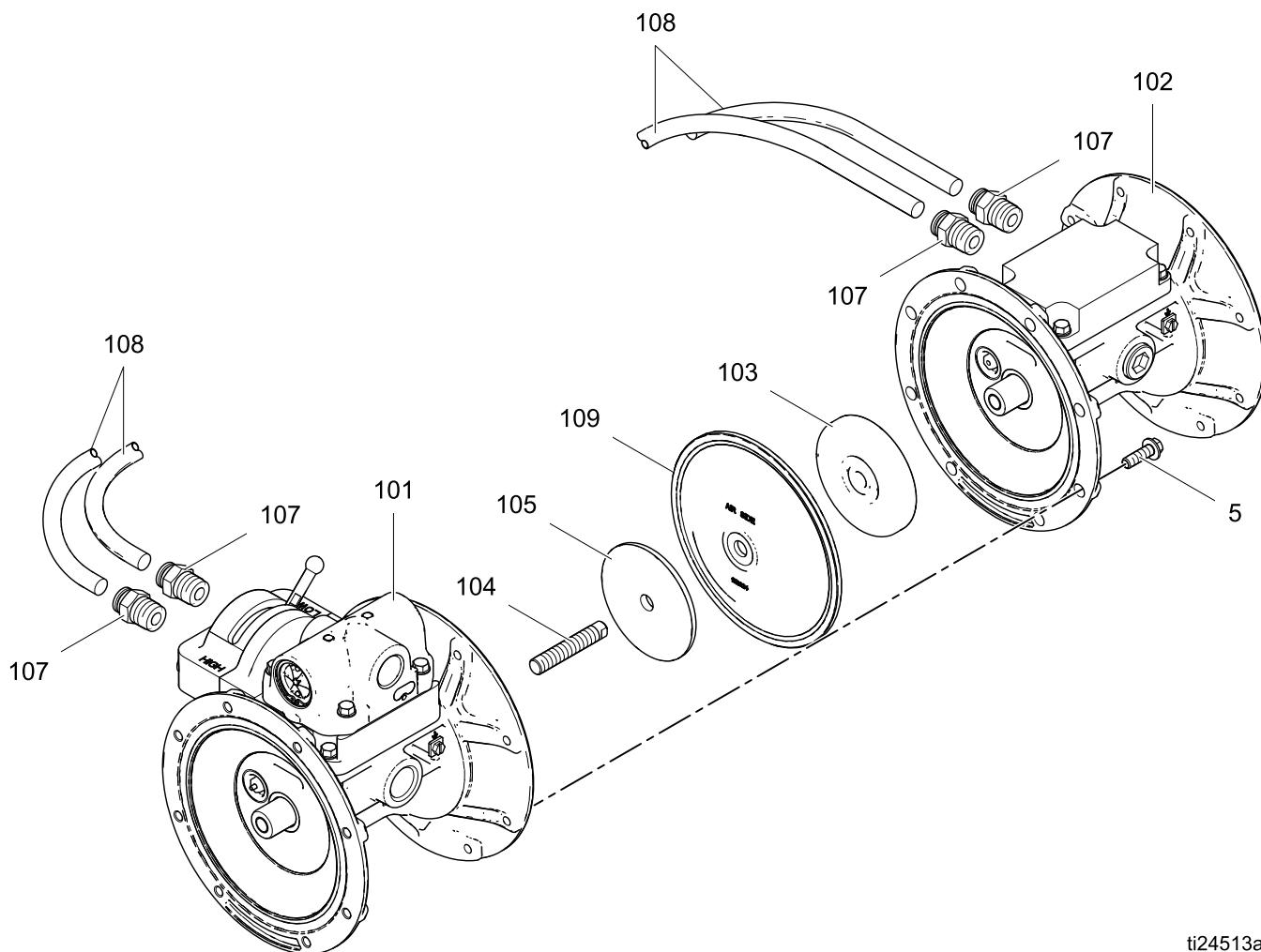

ti24513a

Ref	Description	Qty	Ref	Description	Qty
101	AIR MODULE, primary, <i>see page 28</i>	1	107	FITTING, air, 1/2 npt x 1/2 T, <i>see page 32</i>	4
102	AIR MODULE, secondary, <i>see page 30</i>	1	108	HOSE, air; 15 in. (381 mm) segment, <i>see page 32</i>	2
103*	PLATE, air, secondary side	1	109*	DIAPHRAGM, Santoprene	1
104*	SCREW, set, M12	1	* Parts included in the Air Section Rebuild Kit. <i>See page 32.</i>		
105*	PLATE, air, primary side	1			

# Primary Air Module

*Sample Configuration Number*

Pump Model	Fluid Section	Air Section	Seats	Balls	Diaphragms	Connections	Options
VA 25HP	A	<b>A</b>	SS	SP	SP	TB	00

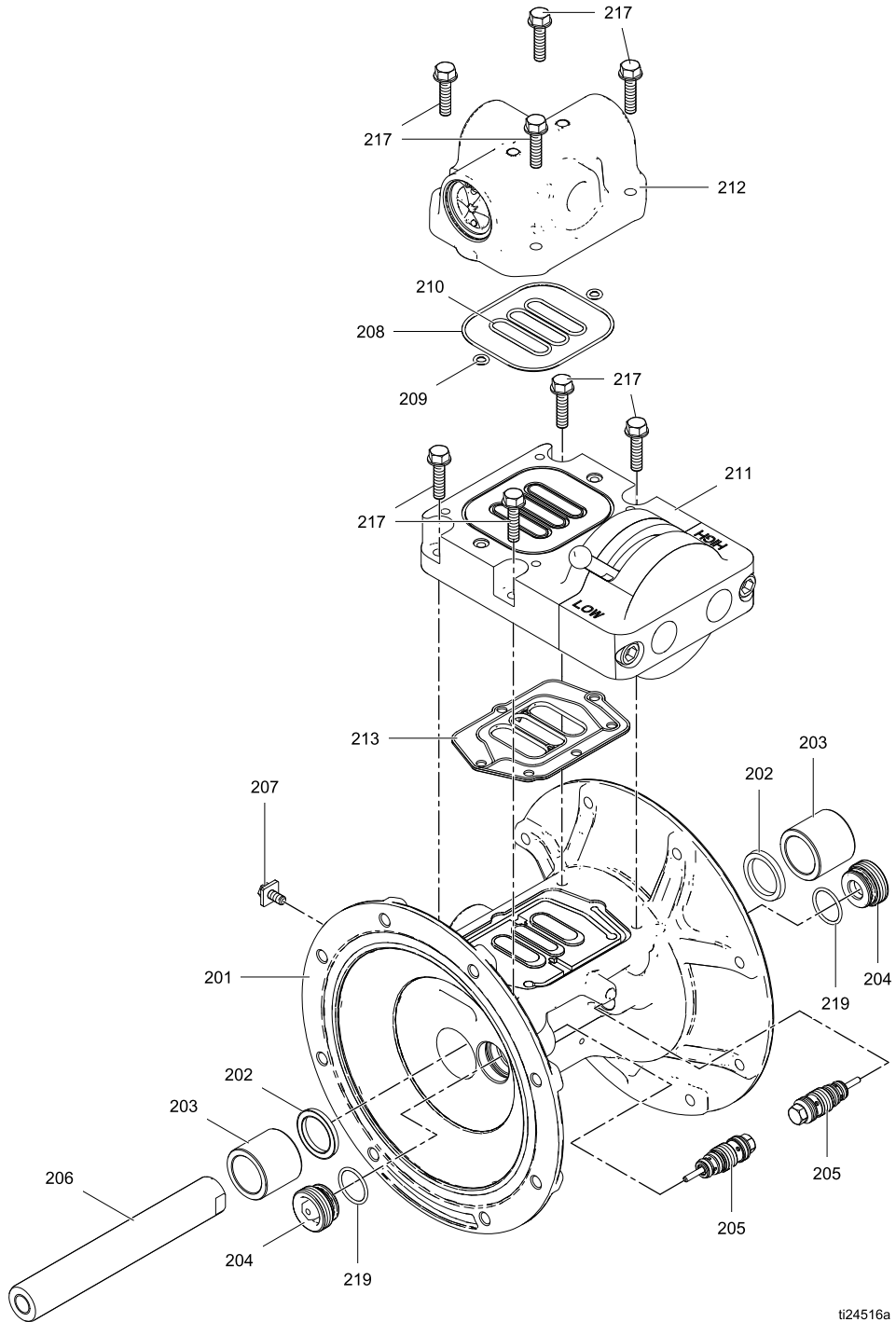

ti24516a

Ref	Description	Qty	Ref	Description	Qty
201	HOUSING, center, not sold separately	1	210	O-RING, Buna-N, 29 mm (1.125 in.) OD, <i>see page 33</i>	3
202*	U-CUP, center shaft	2	211	VALVE, High/Low, <i>see page 37</i>	1
203*	BEARING, center shaft	2	212	VALVE, air, <i>see page 34</i>	1
204*	CARTRIDGE, pilot receiver	2	213*	GASKET, air valve	1
205*	VALVE, pilot	2	217*	SCREW, M6 x 25, thread forming	8
206*	SHAFT, center	1	219*	O-RING, receiver cartridge, Buna-N, 23 mm (0.9 in.) OD	2
207	SCREW, ground, Order PN 819.0220	1	<i>* Parts included in the Air Section Rebuild Kit. See page 32.</i>		
208	O-RING, Buna-N, 81 mm (3.2 in.) OD, <i>see page 33</i>	1			
209	O-RING, Buna-N, 9 mm (0.35 in.) OD, <i>see page 33</i>	2			

## Secondary Air Module

*Sample Configuration Number*

Pump Model	Fluid Section	Air Section	Seats	Balls	Diaphragms	Connections	Options
VA 25HP	A	<b>A</b>	SS	SP	SP	TB	00

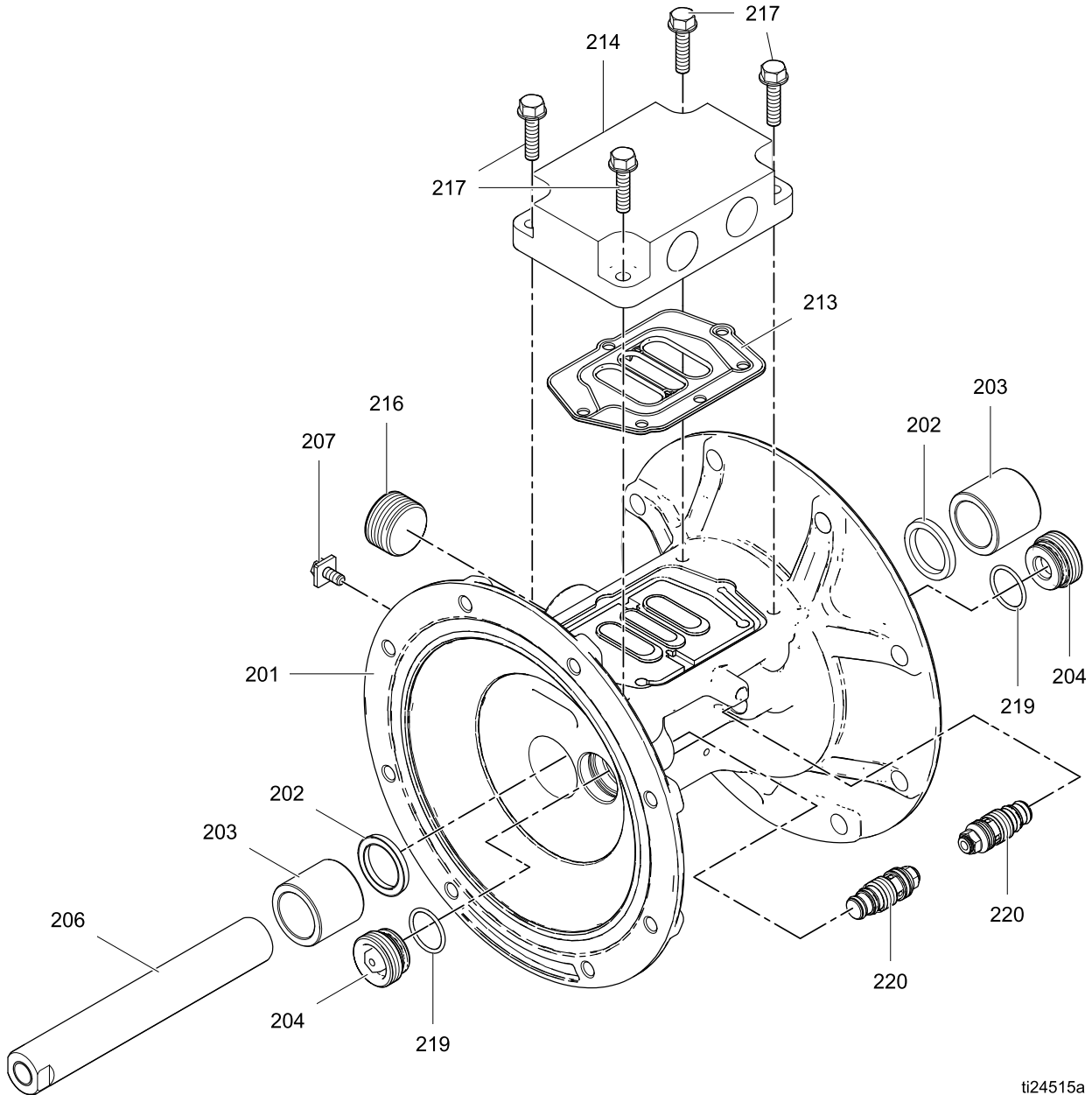

ti24515a

Ref	Description	Qty	Ref	Description	Qty
201	HOUSING, center, not sold separately	1	213*	GASKET, air valve	1
202*	U-CUP, center shaft	2	216	PLUG, pipe, order PN 819.4463	1
203*	BEARING, center shaft	2	217*	SCREW, M6 x 25, thread forming	4
204*	CARTRIDGE, pilot receiver	2	219*	O-RING, receiver cartridge, Buna-N, 23 mm (0.9 in.) OD	2
206*	SHAFT, center	1	220*	PLUG, secondary pilot	2
207	SCREW, ground, order PN 819.0220	1	* <i>Parts included in the Air Section Rebuild Kit. See page 32.</i>		
214	PLATE, adapter, <i>see page 33</i>	1			

## Air Section Kits

*Sample Configuration Number*

Pump Model	Fluid Section	Air Section	Seats	Balls	Diaphragms	Connections	Options
VA 25HP	A	<b>A</b>	SS	SP	SP	TB	00

### Air Section Rebuild Kit 859.0379

Kit includes:

- 2 center shaft (206)
- 4 center shaft bearings (203)
- 4 center shaft u-cups (202)
- 2 air valve gasket (213)
- 8 screws (217)
- 8 seat o-rings (9)
- 2 pilot valves (205)
- 2 secondary pilot plugs (220)
- 4 pilot valve receiver cartridges (204)
- 4 receiver cartridge o-rings (219)
- 1 grease packet
- 1 air plate, secondary side (103)
- 1 air plate, primary side (105)
- 1 set screw, M12 (104)
- 1 diaphragm, Santoprene (109)

### Hose and Fitting Kit 859.0380

Kit includes:

- 4 air fittings (107)
- 2 air hoses (108)

### Center Diaphragm Kit 859.0386

Kit includes:

- 1 air plate, secondary side (103)
- 1 air plate, primary side (105)
- 1 set screw, M12 (104)
- 1 diaphragm, Santoprene (109)

### Pilot Valve Assembly Kit 859.0036

Kit includes:

- 2 pilot valve assemblies (205)
- 2 receiver cartridges (204)
- 2 receiver cartridge o-rings (219)
- 1 grease packet

### Secondary Pilot Plug Assembly Kit 859.0395

Kit includes:

- 2 secondary pilot plug assemblies (220)
- 2 receiver cartridges (204)
- 2 receiver cartridge o-rings (219)
- 1 grease packet

### Center Shaft Kit 859.0035

**NOTE:** Purchase 2 kits if you are rebuilding both the primary and secondary air modules.

Kits include:

- 2 center shaft u-cups (202)
- 1 center shaft (206)
- 2 center shaft bearings (203)
- 1 grease packet

### Center Shaft Bearing Kit 859.0037

**NOTE:** Purchase 2 kits if you are rebuilding both the primary and secondary air modules.

Kit includes:

- 2 center shaft u-cups (202)
- 2 center shaft bearings (203)
- 1 grease packet



**High/Low Manifold Seals Kit 859.0385**

Kit includes:

- 1 o-ring (208)
- 2 o-rings (209)
- 3 o-rings (210)
- 1 air valve gasket (213)

**Adapter Plate Kit 859.0384**

Kit includes:

- 1 adapter plate (214)
- 4 screws (217)
- 1 air valve gasket (213)

# Air Valve

*Sample Configuration Number*

Pump Model	Fluid Section	Air Section	Seats	Balls	Diaphragms	Connections	Options
VA 25HP	A	<b>A</b>	SS	SP	SP	TB	00

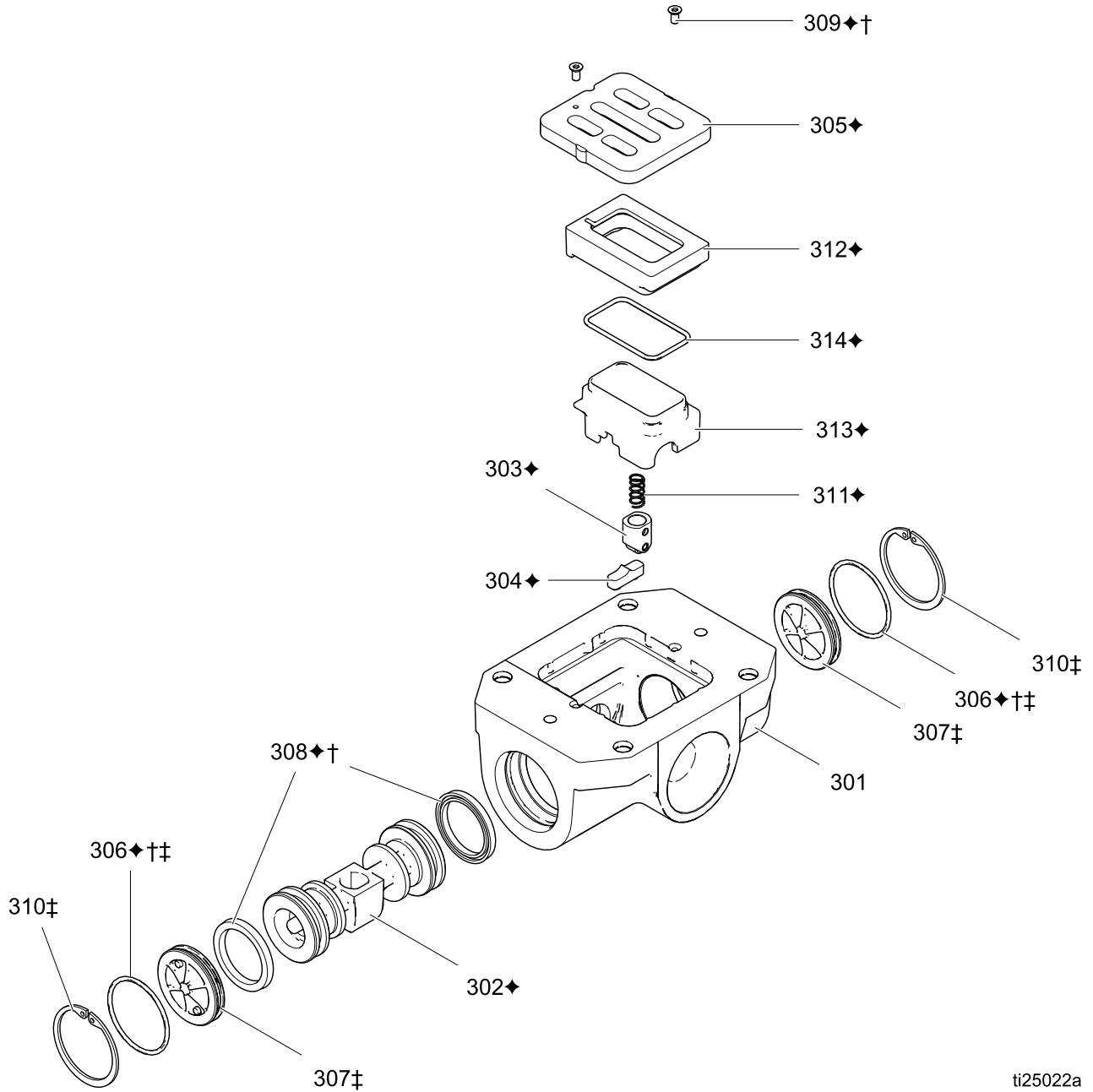

ti25022a

Ref	Description	Qty	Ref	Description	Qty
301	HOUSING, not sold separately	1	308◆†	U-CUP, carboxylated nitrile	2
302◆	PISTON	1	309◆†	SCREW, M3, thread forming	2
303◆	PISTON ASSEMBLY, detent	1	310‡	RETAINING RING	2
304◆	CAM, detent	1	311◆	SPRING, detent	1
305◆	PLATE, air valve	1	312◆	BASE, cup	1
306◆†‡	O-RING	2	313◆	CUP	1
307‡	CAP, end	2	314◆	O-RING, cup	1

◆ *Parts included in Air Valve Repair Kit. See page 36.*

‡ *Parts included in Air Valve End Cap Kit. See page 36.*

† *Parts included in Air Valve Seals Kit.. See page 36.*

Parts

Sample Configuration Number

Pump Model	Fluid Section	Air Section	Seats	Balls	Diaphragms	Connections	Options
VA 25HP	A	A	SS	SP	SP	TB	00

† Air Valve Seals Kit 859.0159

Kit includes:

- 2 end cap o-rings (306)
- 2 piston u-cups (308)
- 2 screws, M3, shorter (309)
- 2 screws, #4, longer (not used)
- 1 air valve gasket (213)
- 1 grease packet
- 1 solenoid release button o-ring (not shown, not used)

◆ Air Valve Repair Kit 859.0160

Kit includes:

- 1 air valve piston (302)
- 1 detent piston assembly (303)
- 1 detent cam (304)
- 1 air valve plate (305)
- 2 end cap o-rings (306)
- 2 piston u-cups (308)
- 2 screws, M3, shorter (309)
- 2 screws, #4, longer (not used)
- 1 detent spring (311)
- 1 air cup base (312)
- 1 air cup (313)
- 1 air cup o-ring (314)
- 1 solenoid release button o-ring (not shown, not used)
- 1 air valve gasket (213)
- 1 grease packet

Air Valve Replacement Kit 859.0392

Kit includes:

- 1 air valve assembly (212)
- 1 o-ring (208)
- 2 o-rings (209)
- 3 o-rings (210)
- 4 screws (217)

‡ Air Valve End Cap Kit 859.0103

Kit includes:

- 2 end caps (307)
- 2 retaining rings (310)
- 2 o-rings (306)

## High/Low Valve

### Sample Configuration Number

Pump Model	Fluid Section	Air Section	Seats	Balls	Diaphragms	Connections	Options
VA 25HP	A	A	SS	SP	SP	TB	00

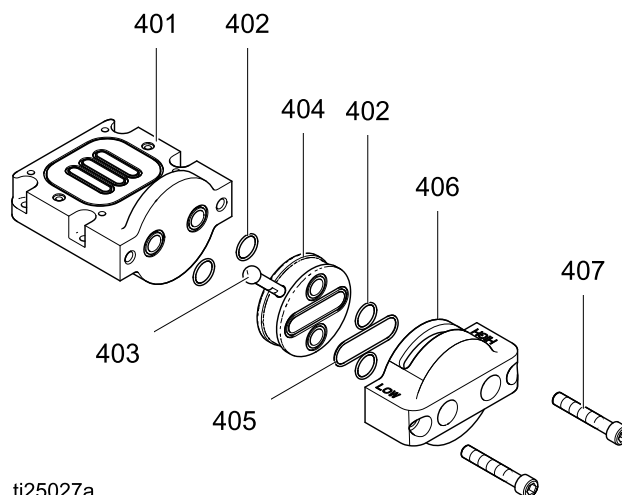

Ref	Description	Qty	Ref	Description	Qty
401	PLATE, adapter, not sold separately	1	406	CAP, adapter plate, not sold separately	1
402	O-RING, PTFE, 20 mm ( 0.8 in.) OD	4	407	SCREW, cap, socket head, 3/8-16 x 2.25; order PN 859.0399	2
403	LEVER, HIGH-LOW shift	1			
404	SPOOL	1			
405	O-RING, PTFE, 48 mm (1.9 in.) OD	1			

### High/Low Valve Replacement Kit 859.0381

Kit includes:

- 1 High/Low valve assembly (211)
- 1 air valve gasket (213)
- 4 screws (217)
- 1 grease packet

### High/Low Valve Seals Kit 859.0382

Kit includes:

- 4 o-rings (402)
- 1 o-ring (405)
- 1 grease packet

### High/Low Valve Spool Kit 859.0383

Kit includes:

- 1 Spool (404)
- 4 o-rings (402)
- 1 o-ring (405)
- 1 lever (403)
- 1 grease packet

## Seats and Check Balls

### Sample Configuration Number

Pump Model	Fluid Section	Air Section	Seats	Balls	Diaphragms	Connections	Options
VA 25HP	A	A	SS	SP	SP	TB	00

Seat Kits	
GE	859.0012
SP	859.0015
SS	859.0016

Kit includes:

- 4 seats (7), material indicated in table
- 8 o-rings, PTFE (9)

Ball Kits	
GE	859.0020
NW	859.0023
SP	859.0025
SS	859.0026

Kit includes:

- 4 balls (8), material indicated in table
- 8 o-rings, PTFE (9)

## Diaphragms

### Sample Configuration Number

Pump Model	Fluid Section	Air Section	Seats	Balls	Diaphragms	Connections	Options
VA 25HP	A	A	SS	SP	SP	TB	00

1-Piece Bolt-Through Diaphragm Kits	
<b>BN</b>	859.0001
<b>SP</b>	859.0007

Kits include:

- 8 o-rings, PTFE (9)
- 2 diaphragms (12), material indicated in table
- 2 o-rings for the bolt (28)
- 1 diaphragm install tool

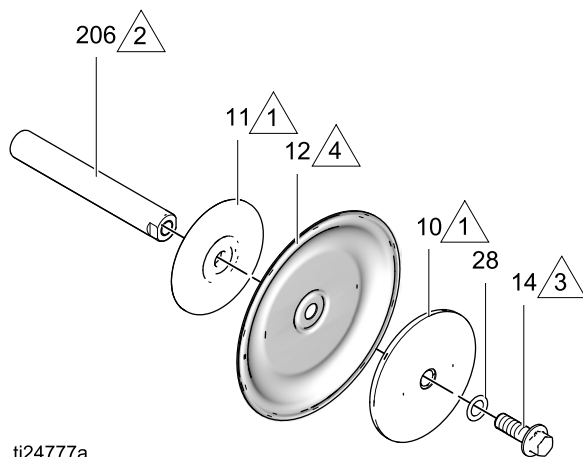

2-Piece Bolt-Through Diaphragm Kits	
<b>TF</b>	859.0414

Kit includes:

- 8 o-rings (9), PTFE
- 2 diaphragms (12), PTFE
- 2 backup diaphragms (13)
- 2 o-rings (28) for the bolt
- 1 diaphragm install tool

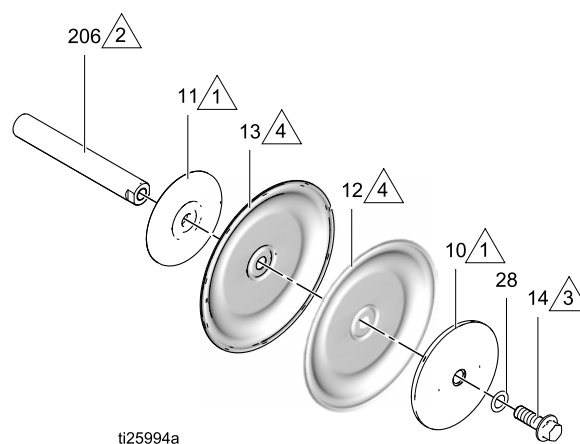

Overmolded Diaphragm Kits	
NO	859.0004

Kit includes:

- 8 o-rings (9), PTFE
- 2 overmolded diaphragms (12), polychloroprene
- 2 diaphragm set screws (15), stainless steel
- 1 diaphragm install tool
- 1 packet anaerobic adhesive

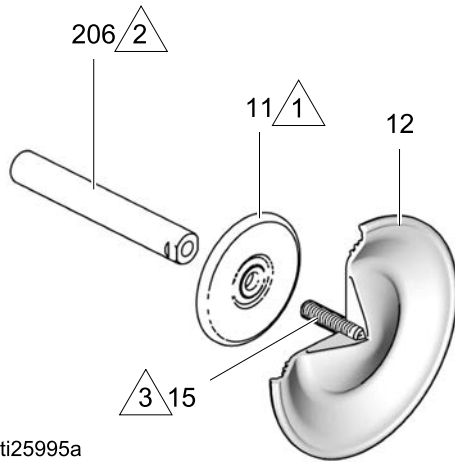

## Aluminum manifold pumps

### Air and Fluid Plate Kit 859.0055

Kit includes:

- 1 air side diaphragm plate (11)
- 1 fluid side diaphragm plate (10), aluminum
- 1 o-ring (28)
- 1 bolt (14)

## Stainless steel manifold pumps

### Air and Fluid Plate Kit 859.0577

Kit includes:

- 1 air side diaphragm plate (11)
- 1 fluid side diaphragm plate (10), stainless steel
- 1 o-ring (28)
- 1 bolt (14)



## Seat, Check Ball, and Diaphragm Kits

### Sample Configuration Number

Pump Model	Fluid Section	Air Section	Seats	Balls	Diaphragms	Connections	Options
VA 25HP	A	A	SS	SP	SP	TB	00

Kit	Parts	Qty.
859.0251 (SS, SP, SP)	SEAT, 316 stainless steel	4
	O-RING, PTFE	8
	BALL, santoprene	4
	O-RING	2
	DIAPHRAGM, santoprene	2
	TOOL, install	1
859.0148 (SP, SP, SP)	SEAT, santoprene	4
	O-RING, PTFE	8
	BALL, santoprene	4
	O-RING	2
	DIAPHRAGM, santoprene	2
	TOOL, install	1
859.0415 (GE, GE, BN)	SEAT, geolast	4
	O-RING, PTFE	8
	BALL, geolast	4
	O-RING	2
	DIAPHRAGM, Buna-n	2
	TOOL, install	1

Kit	Parts	Qty.
859.0416 (SS, NW, BN)	SEAT, 316 stainless steel	4
	O-RING, PTFE	8
	BALL, polychloroprene, weighted	4
	O-RING	2
	DIAPHRAGM, Buna-n	2
	TOOL, install	1
859.0417 (SS, NW, NO)	SEAT, 316 stainless steel	4
	O-RING, PTFE	8
	BALL, polychloroprene, weighted	4
	O-RING	2
	DIAPHRAGM, polychloroprene, overmolded	2
	TOOL, install	1
859.0418 (SS, SS, TF)	SEAT, 316 stainless steel	4
	O-RING, PTFE	8
	BALL, 316 stainless steel	4
	O-RING	2
	DIAPHRAGM, PTFE/Santoprene, 2-piece	2
	TOOL, install	1

# Technical Data

	US	Metric
<b>Maximum fluid working pressure</b>	250 psi	17.2 bar, 1.72 MPa
<b>Air pressure operating range</b> (Startup pressure may vary based on environmental conditions.)	20-125 psi	1.4-8.6 bar, 0.14-0.86 MPa
<b>Fluid displacement per cycle</b>		
Low Pressure Setting	0.17 g	0.64 l
High Pressure Setting	0.20 g	0.76 l
<b>Air consumption</b>	<b>at 70 psi, 20 gpm</b>	<b>at 4.8 bar, 76 lpm</b>
Low Pressure Setting	26 scfm	0.7 cubic meters per minute
High Pressure Setting	51 scfm	1.4 cubic meters per minute
<b>Maximum values with water as media under submerged inlet conditions at ambient temperature:</b>		
Maximum air consumption		
Low Pressure Setting	59 scfm	1.7 cubic meters per minute
High Pressure Setting	95 scfm	2.7 cubic meters per minute
Maximum free-flow delivery		
Low Pressure Setting	50 gpm	189 lpm
High Pressure Setting	46 gpm	174 lpm
Maximum pump speed		
Low Pressure Setting	280 cpm	
High Pressure Setting	225 cpm	
Maximum suction lift (varies widely based on ball/seat selection and wear, operating speed, material properties, and other variables)	16 ft dry, 29 ft wet	4.9 m dry 8.8 m wet
<b>Maximum size pumpable solids</b>	1/8 in	3.2 mm
<b>Recommended cycle rate for continuous use</b>	93-140 cpm (in Low or High setting)	
<b>Recommended cycle rate for circulation systems</b>	20 cpm (in Low or High setting)	
<b>Air inlet size</b>	3/4 npt(f)	
<b>Fluid inlet size</b>	1 in. npt(f) or 1 in. bspt	
<b>Fluid outlet size</b>	1 in. npt(f) or 1 in. bspt	
<b>Weight</b>	48 lb (aluminum manifolds) 60 lb (SST manifolds)	21.8 kg (aluminum manifolds) 27.2 kg (SST manifolds)

<b>Sound Power</b> (measured per ISO-9614-2)	
At 4.8 bar (0.48 MPa, 70 psi) and 50 cpm	
Low Pressure Setting	78 dBa
High Pressure Setting	91 dBa
At 8.6 bar (0.86 MPa, 125 psi) and full flow	
Low Pressure Setting	90 dBa
High Pressure Setting	102 dBa
<b>Sound Pressure</b> (tested 3.28 ft [1 m] from equipment)	
At 4.8 bar (0.48 MPa, 70 psi) and 50 cpm	
Low Pressure Setting	84 dBa
High Pressure Setting	96 dBa
At 8.6 bar (0.86 MPa, 125 psi) and full flow	
Low Pressure Setting	84 dBa
High Pressure Setting	96 dBa
<b>Wetted parts</b>	aluminum or stainless steel plus the material(s) chosen for seat, ball, and diaphragm options.
<b>Non-wetted external parts</b>	aluminum, coated carbon steel

## Fluid Temperature Range

<b>NOTICE</b>
Temperature limits are based on mechanical stress only. Certain chemicals will further limit the fluid operating temperature range. Stay within the temperature range of the most-restricted wetted component. Operating at a fluid temperature that is too high or too low for the components of your pump may cause equipment damage.

Diaphragm/Ball Material	Fluid Temperature Range	
	Fahrenheit	Celsius
Buna-N (BN)	10° to 180°F	-12° to 82°C
Geolast (GE)	-40° to 150°F	-40° to 66°C
Polychloroprene overmolded diaphragm (NO) or Polychloroprene check balls (NW)	0° to 180°F	-18° to 82°C
2-Piece PTFE/Santoprene Diaphragm	40° to 180°F	4° to 82°C
Santoprene® (SP)	-40° to 180°F	-40° to 82°C



# Customer Services/Guarantee

## CUSTOMER SERVICES

If you require spare parts, please contact your local distributor, providing the following details:

- Pump Model
- Type
- Serial Number, and
- Date of First Order.

## GUARANTEE

All VERDER pumps are warranted to the original user against defects in workmanship or materials under normal use (rental use excluded) for two years after purchase date. This warranty does not cover failure of parts or components due to normal wear, damage or failure which in the judgement of VERDER arises from misuse.

Parts determined by VERDER to be defective in material or workmanship will be repaired or replaced.

## LIMITATION OF LIABILITY

To the extent allowable under applicable law, VERDER's liability for consequential damages is expressly disclaimed. VERDER's liability in all events is limited and shall not exceed the purchase price.

## WARRANTY DISCLAIMER

VERDER has made an effort to illustrate and describe the products in the enclosed brochure accurately; however, such illustrations and descriptions are for the sole purpose of identification and do not express or imply a warranty that the products are merchantable, or fit for a particular purpose, or that the products will necessarily conform to the illustration or descriptions.

## PRODUCT SUITABILITY

Many regions, states and localities have codes and regulations governing the sale, construction, installation and/or use of products for certain purposes, which may vary from those in neighboring areas. While VERDER attempts to assure that its products comply with such codes, it cannot guarantee compliance, and cannot be responsible for how the product is installed or used. Before purchasing and using a product, please review the product application as well as the national and local codes and regulations, and be sure that product, installation, and use complies with them.

Original instructions. This manual contains English.

Revision K, December 2019

**Austria**

Verder Austria  
Eitnergasse 21/Top 8  
A-1230 Wien  
AUSTRIA  
Tel: +43 1 86 51 074 0  
Fax: +43 1 86 51 076  
e-mail: office@verder.at

**Belgium**

Verder nv  
Kontichsesteenweg 17  
B-2630 Aartselaar  
BELGIUM  
Tel: +32 3 877 11 12  
Fax: +32 3 877 05 75  
e-mail: info@verder.be

**China**

Verder Shanghai Instruments and Equipment Co., Ltd  
Building 8 Fuhai Business Park No. 299  
Bisheng Road, Zhangjiang Hiteck Park  
Shanghai 201204  
CHINA  
Tel: +86 21 33932950  
Fax: +86 21 33932955  
e-mail: info@verder.cn

**Bulgaria**

Verder Bulgaria Ltd  
Vitosh department,  
Manastriski Livadi Zapad  
district,  
110 Bulgaria Blvd., 2-nd  
Floor, apt. 15-16,  
1618 - Sofia  
BULGARIA  
Tel: 0878407370  
Fax: 02 9584085  
email: office@verder.bg

**Czech Republic**

Verder s.r.o.  
Vodnanská 651/6 (vchod  
Chlumecka 15)  
198 00 Praha 9-Kyje  
CZECH REPUBLIC  
Tel: +420 261 225 386-7  
Web: <http://www.verder.cz>  
e-mail: info@verder.cz

**France**

Verder France  
8 Allée Rosa Luxembourg  
Immeulde Arizona  
95610 Eragny sur Oise  
FRANCE  
Tel: +33 173 43 98 41  
Fax: +33 134 64 44 50  
e-mail: info@verder.fr

**Germany**

Verder Deutschland GmbH  
Retsch-Allee 1-5  
42781 Haan  
GERMANY  
Tel: 02104/2333-200  
Fax: 02104/2333-299  
e-mail: info@verder.de

**Hungary**

Verder Hungary Kft  
Budafoke ut 187 - 189  
HU-1117 Budapest  
HUNGARY  
Tel: 0036 1 3651140  
Fax: 0036 1 3725232  
e-mail: info@verder.hu

**India**

Verder India Pumps Pvt  
Ltd.  
Plot No-3B, D-1 Block,  
MIDC Chinchwad,  
Pune - 411019  
INDIA  
e-mail:  
Sales@verder.co.in  
[www.verder.co.in](http://www.verder.co.in)

**Italy**

Verder Italia  
Via Maestri Del lavoro, 5  
02100 Vazia, Rieti  
ITALY  
Tel: +39 07 46 229064  
e-mail: info@verder.it

**The Netherlands**

Verder BV  
Leningradweg 5  
NL 9723 TP Groningen  
THE NETHERLANDS  
Tel: +31 50 549 59 00  
Fax: +31 50 549 59 01  
e-mail: info@verder.nl

**Poland**

Verder Polska  
ul.Porcelanowa 23  
PL-40 036 Katowice  
POLAND  
Tel: +48 32 78 15 032  
Fax: +48 32 78 15 034  
e-mail: verder@verder.pl

**Romania**

Verder România  
Drumul Balta Doamnei  
no 57-61  
Sector 3  
CP 72-117  
032624 Bucuresti  
ROMANIA  
Tel: +40 21 335 45 92  
Fax: +40 21 337 33 92  
e-mail: office@verder.ro

**Slovak Republik**

Verder Slovakia s.r.o.  
Silacska 1  
SK-831 02 Bratislava  
SLOVAK REPUBLIK  
Tel: +421 2 4463 07 88  
Fax: +421 2 4445 65 78  
e-mail: info@verder.sk

**South Africa**

Verder SA  
197 Flaming Rock Avenue  
Northlands Business Park  
Newmarket Street  
ZA Northriding  
SOUTH AFRICA  
Tel: +27 11 704 7500  
Fax: +27 11 704 7515  
e-mail: info@verder.co.za

**Switzerland**

Verder Deutschland GmbH  
Sales Switzerland  
Retsch-Allee 1-5  
D-42781 Haan  
GERMANY  
Tel: +41 (0)61 331 33 13  
Fax: +41 (0)61 331 63 22  
e-mail: info@verder.ch

**United Kingdom**

Verder UK Ltd.  
Unit 3 California Drive  
Castleford, WF10 5QH  
UNITED KINGDOM  
Tel: +44 (0) 1924 221 001  
Fax: +44 (0) 1132 465 649  
e-mail: info@verder.co.uk

**United States of America**

Verder Inc.  
312 Corporate Parkway  
Suite 101  
Macon, GA 31210  
USA  
Tel: +1 877 783 7337  
Fax: +1 478 476 9867  
e-mail: sales@verder-us.com