

VERDERAIR VA-E25

Electric Diaphragm Pump

859.0511
Rev.G
EN

1-Inch pumps with electric drive for fluid transfer applications. For professional use only.



Important Safety Instructions

Read all warnings and instructions in this manual and in your VERDERAIR VA-E25 Operation manual. **Save these instructions.**

For maximum operating pressures, see the Performance Charts on pages 23–25 of the Operation manual.

See pages 6–7 for model information, including approvals.

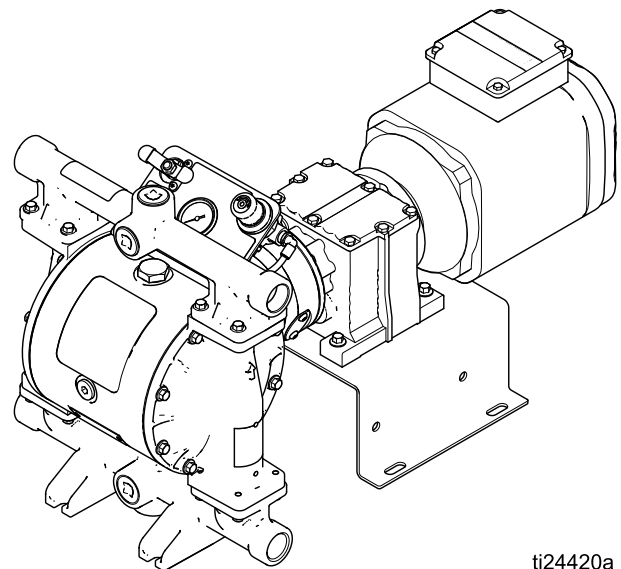

ti24420a



Contents



Related Manuals	2	Center Section Repair	16
Warnings	3	Disconnect the Motor and Gearbox	21
Pump Matrix	6	Replace the Compressor	22
Overview	8	Torque Instructions	23
Troubleshooting	9	Parts	24
Repair	11	Kits and Accessories	37
Pressure Relief Procedure	11	Technical Data	38
Check Valve Repair	11	Customer Services/Guarantee	42
Diaphragm Repair	13		







Related Manuals





Manual Number	Title
859.0510	VA-E25 Electric Double Diaphragm Pump, Operation

Warnings

The following warnings are for the setup, use, grounding, maintenance, and repair of this equipment. The exclamation point symbol alerts you to a general warning and the hazard symbols refer to procedure-specific risks. When these symbols appear in the body of this manual or on warning labels, refer back to these Warnings. Product-specific hazard symbols and warnings not covered in this section may appear throughout the body of this manual where applicable.

 <h1 style="margin: 0;">WARNING</h1>	
	<p>ELECTRIC SHOCK HAZARD</p> <p>This equipment must be grounded. Improper grounding, setup, or usage of the system can cause electric shock.</p> <ul style="list-style-type: none"> • Turn off and disconnect power at main switch before disconnecting any cables and before servicing or installing equipment. • Connect only to grounded power source. • All electrical wiring must be done by a qualified electrician and comply with all local codes and regulations. • Wait five minutes for capacitor discharge before opening equipment.
	<p>FIRE AND EXPLOSION HAZARD</p> <p>Flammable fumes, such as solvent and paint fumes, in work area can ignite or explode. Paint or solvent flowing through the equipment can cause static sparking. To help prevent fire and explosion:</p> <ul style="list-style-type: none"> • Use equipment only in well ventilated area. • Eliminate all ignition sources; such as pilot lights, cigarettes, portable electric lamps, and plastic drop cloths (potential static arc). • Ground all equipment in the work area. See Grounding instructions. • Keep work area free of debris, including solvent, rags and gasoline. • Do not plug or unplug power cords, or turn power or light switches on or off when flammable fumes are present. • Use only grounded hoses. • Stop operation immediately if static sparking occurs or you feel a shock. Do not use equipment until you identify and correct the problem. • Keep a working fire extinguisher in the work area. <p>Static charge may build up on plastic parts during cleaning and could discharge and ignite flammable vapors. To help prevent fire and explosion:</p> <ul style="list-style-type: none"> • Clean plastic parts only in well ventilated area. • Do not clean with a dry cloth. • Do not operate electrostatic guns in equipment work area.

 <h1 style="margin: 0;">WARNING</h1>	
 	<p>PRESSURIZED EQUIPMENT HAZARD</p> <p>Fluid from the equipment, leaks, or ruptured components can splash in the eyes or on skin and cause serious injury.</p> <ul style="list-style-type: none"> • Follow the Pressure Relief Procedure when you stop spraying/dispensing and before cleaning, checking, or servicing equipment. • Tighten all fluid connections before operating the equipment. • Check hoses, tubes, and couplings daily. Replace worn or damaged parts immediately.
 	<p>EQUIPMENT MISUSE HAZARD</p> <p>Misuse can cause death or serious injury.</p> <ul style="list-style-type: none"> • Do not operate the unit when fatigued or under the influence of drugs or alcohol. • Do not exceed the maximum working pressure or temperature rating of the lowest rated system component. See Technical Data in all equipment manuals. • Use fluids and solvents that are compatible with equipment wetted parts. See Technical Data in all equipment manuals. Read fluid and solvent manufacturer's warnings. For complete information about your material, request Safety Data Sheet (SDS) from distributor or retailer. • Turn off all equipment and follow the Pressure Relief Procedure when equipment is not in use. • Check equipment daily. Repair or replace worn or damaged parts immediately with genuine manufacturer's replacement parts only. • Do not alter or modify equipment. Alterations or modifications may void agency approvals and create safety hazards. • Make sure all equipment is rated and approved for the environment in which you are using it. • Use equipment only for its intended purpose. Call your distributor for information. • Route hoses and cables away from traffic areas, sharp edges, moving parts, and hot surfaces. • Do not kink or over bend hoses or use hoses to pull equipment. • Keep children and animals away from work area. • Comply with all applicable safety regulations.
	<p>PRESSURIZED ALUMINUM PARTS HAZARD</p> <p>Use of fluids that are incompatible with aluminum in pressurized equipment can cause serious chemical reaction and equipment rupture. Failure to follow this warning can result in death, serious injury, or property damage.</p> <ul style="list-style-type: none"> • Do not use 1,1,1-trichloroethane, methylene chloride, other halogenated hydrocarbon solvents or fluids containing such solvents. • Do not use chlorine bleach. • Many other fluids may contain chemicals that can react with aluminum. Contact your material supplier for compatibility.

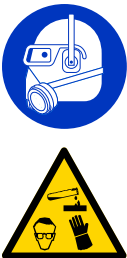
 <h1 style="margin: 0;">WARNING</h1>	
	<p>THERMAL EXPANSION HAZARD</p> <p>Fluids subjected to heat in confined spaces, including hoses, can create a rapid rise in pressure due to the thermal expansion. Over-pressurization can result in equipment rupture and serious injury.</p> <ul style="list-style-type: none"> Open a valve to relieve the fluid expansion during heating. Replace hoses proactively at regular intervals based on your operating conditions.
	<p>PLASTIC PARTS CLEANING SOLVENT HAZARD</p> <p>Many solvents can degrade plastic parts and cause them to fail, which could cause serious injury or property damage.</p> <ul style="list-style-type: none"> Use only compatible water-based solvents to clean plastic structural or pressure-containing parts. See Technical Data in this and all other equipment instruction manuals. Read fluid and solvent manufacturer's Safety Data Sheet (SDS) and recommendations.
	<p>TOXIC FLUID OR FUMES HAZARD</p> <p>Toxic fluids or fumes can cause serious injury or death if splashed in the eyes or on skin, inhaled, or swallowed.</p> <ul style="list-style-type: none"> Read Safety Data Sheet (SDS) to know the specific hazards of the fluids you are using. Store hazardous fluid in approved containers, and dispose of it according to applicable guidelines.
	<p>BURN HAZARD</p> <p>Equipment surfaces and fluid that's heated can become very hot during operation. To avoid severe burns:</p> <ul style="list-style-type: none"> Do not touch hot fluid or equipment.
	<p>PERSONAL PROTECTIVE EQUIPMENT</p> <p>Wear appropriate protective equipment when in the work area to help prevent serious injury, including eye injury, hearing loss, inhalation of toxic fumes, and burns. This protective equipment includes but is not limited to:</p> <ul style="list-style-type: none"> Protective eyewear, and hearing protection. Respirators, protective clothing, and gloves as recommended by the fluid and solvent manufacturer.

Pump Matrix

Check the identification plate (ID) for the Configuration Number of your pump. Use the following matrix to define the components of your pump.

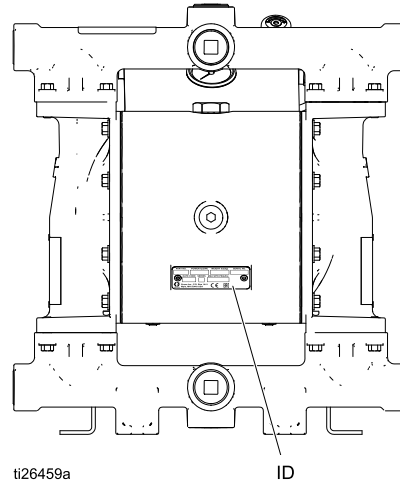





Sample Configuration Number: **VA-E25 AA HY AC HY TB AC**

VA-E25	A	A	HY	AC	HY	TB	AC
Pump Model	Fluid Section Material	Drive Section Material	Check Valve Material	Check Valve Balls	Diaphragm	Connections	Options

Pump	Fluid Section Material		Drive Section Material		Check Valve Material	
VA-E25	A	Aluminum	A	Aluminum	AC	Acetal
	P	Polypropylene	S	Stainless Steel	AL	Aluminum
	S	Stainless Steel			BN	Buna-N
					GE	Geolast
					HY	TPE
					PP	Polypropylene
					SP	Santoprene
					SS	316 Stainless Steel
					VT	FKM Fluoroelastomer

Balls		Diaphragm		Connections		Options	
AC	Acetal	BN	Buna-N	FC	Center Flange DIN/ANSI	AC	Standard AC Induction Motor with Gearbox (2-pole)
BN	Buna-N	GE	Geolast	FE	End Flange DIN/ANSI	AX	AC Induction Motor, ATEX (2-pole)◆
GE	Geolast	HY	TPE	TB	Threaded BSP	AF	Explosionproof AC Induction Motor (2-pole)★
HY	TPE	NO	Polychloroprene Overmolded	TN	Threaded NPT	NG	NEMA 56 C Gearbox +
NE	Polychloroprene Standard	SP	Santoprene			IG	IEC 90 B5 Flange Gearbox +
NW	Polychloroprene Weighted	TF	PTFE/EPDM 2-Piece			B1	Standard AC Induction Motor with Compressor (120V, 4-pole)
SP	Santoprene	TO	PTFE/EPDM Overmolded			B2	Standard AC Induction Motor with Compressor (240V, 4-pole)
SS	316 Stainless Steel	VT	FKM Fluoroelastomer			BC	Standard AC Induction Motor with Gearbox (4-pole)
TF	PTFE					BX	AC Induction Motor, ATEX (4-pole)◆
VT	FKM Fluoroelastomer						

Approvals	
◆ Aluminum and stainless steel pumps with code AX and BX are certified to:	 II 2 G ck Ex d IIB T3 Gb
+ Aluminum and stainless steel pumps with code NG or IG are certified to:	 II 2 G ck IIB T3 Gb
★ Motors coded AF are certified to:	 UL LISTED Class1, Zone 1, AEx d IIB T3 0°C<Ta<40°C 
All Models (except AF) are certified to:	

Overview

The VERDERAIR VA-E25 product line offers electric-powered diaphragm pumps in a wide range of models. This section shows the basic structure of available models. Fluid section options are too numerous to include. The many manifold, seat,

ball, and diaphragm options are available on a wide variety of these models.

Center Section	Motor Type	Controller	Gearbox	Compressor	Approval Options
Aluminum or Stainless Steel	AC	VFD — not included.	Yes, part of motor	Yes-120V	None
				Yes-240V	CE
				No	
			IEC	No	ATEX and CE
	NEMA	No	Explosionproof		
	None	None	NEMA	No	CE
			IEC	No	

Key Points:

- Pumps are available with an AC motor, or with just a gearbox (for applications where a motor already is available).
- Verder recommends the use of a motor soft starter or a VFD in the electrical circuit for all installations. See the motor manufacturer’s recommendations for proper installation when using either of these

components. In all cases, make sure all products are installed in accordance with local codes and regulations.

- The standard AC motor (not ATEX or Explosionproof) is available in models without a compressor, with a 120V compressor, or with a 240V compressor.

Troubleshooting



- Follow the [Pressure Relief Procedure, page 11](#), before checking or servicing the equipment.
- Check all possible problems and causes before disassembly.

Problem	Cause	Solution
Pump cycles but will not prime and/or pump.	Pump is running too fast, causing cavitation before prime.	Slow down the motor controller.
	Center section has no air pressure, or air pressure is too low.	Apply air pressure to center section per your application requirements.
	Check valve ball is severely worn or wedged in seat or manifold.	Replace the ball and seat.
	The pump has insufficient suction pressure.	Increase the suction pressure. See the Operation manual.
	Seat is severely worn.	Replace the ball and seat.
	Outlet or inlet is restricted.	Remove the restriction.
	Inlet fittings or manifolds are loose.	Tighten.
	Manifold o-rings are damaged.	Replace o-rings.
The center section is excessively hot.	The drive shaft is broken.	Replace.
Pump fails to hold fluid pressure at stall.	Check valve balls, seats, or o-rings are worn.	Replace.
	Manifold screws or fluid cover screws are loose.	Tighten.
	Diaphragm shaft bolt is loose	Tighten.
Pump will not cycle.	Motor or controller is wired improperly.	Wire per manual.
	The leak detector (if installed) has tripped.	Check diaphragm for rupture or incorrect installation. Repair or replace.
The motor is operating, but the pump will not cycle.	The jaw coupling between the motor and gearbox is not connected properly.	Check the connection.
Pump flow rate is erratic.	Suction line is clogged.	Inspect; clear.
	Check balls are sticky or leaking .	Clean or replace.
	Diaphragm (or backup) ruptured.	Replace.
Pump makes unusual noises.	Pump is operating near or at stall pressure.	Adjust air pressure or slow the pump speed.

Troubleshooting

Problem	Cause	Solution
Air consumption is higher than expected.	A fitting is loose.	Tighten. Inspect thread sealant.
	Loose or damaged o-rings or shaft seal.	Replace.
	Diaphragm (or backup) ruptured.	Replace.
Air bubbles in fluid.	Suction line is loose.	Tighten.
	Diaphragm (or backup) ruptured.	Replace.
	Loose manifolds, damaged seats or o-rings.	Tighten manifold bolts or replace seats or o-rings.
	Loose diaphragm shaft bolt.	Tighten.
Pump leaks fluid externally from joints.	Loose manifold screws or fluid cover screws.	Tighten.
	Manifold o-rings worn out.	Replace o-rings.
The controller faults or shuts down.	A GFCI has tripped.	Remove the controller from the GFCI circuit.
	Supply power is poor.	Determine and fix the source of the power problem.
NOTE: For problems with a Variable Frequency Device (VFD), see your VFD manual.		

Repair

Pressure Relief Procedure



Follow the Pressure Relief Procedure whenever you see this symbol.

<p>This equipment stays pressurized until pressure is relieved manually. To help prevent serious injury from pressurized fluid, such as splashing in the eyes or on skin, follow the Pressure Relief Procedure when you stop pumping and before you clean, check, or service the equipment.</p>				

1. Remove power from the system.
2. Open the dispensing valve, if used.
3. Open the fluid drain valve (L) to relieve fluid pressure. Have a container ready to catch the drainage.
4. Close the pump air valve.
5. **Units with a compressor:** Cycle the valve to bleed any remaining air.

Check Valve Repair

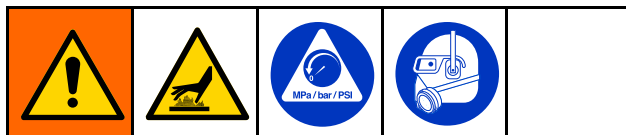

NOTE: Kits are available for new check valve balls and seats in a range of materials. O-ring and fastener kits also are available.

NOTE: To ensure proper seating of the check balls, always replace the seats when replacing the balls. Also, replace the o-rings every time the manifold is removed.

Disassemble the Check Valve

1. Follow the [Pressure Relief Procedure, page 11](#). Remove power from the motor. Disconnect all hoses.
2. **NOTE for plastic pumps:** Use hand tools until thread-locking adhesive patch releases.
3. Use a 10 mm (M8) socket wrench to remove the manifold fasteners (5) and nuts (42; used only on stainless steel models), then remove the outlet manifold (3).
4. Remove the o-rings (8) if present, seats (6), and balls (7).
5. Repeat for the inlet manifold (4), o-rings (8) if present, seats (6), and balls (7).

To continue disassembly, see [Disassemble the Diaphragms, page 13](#).

Reassemble the Check Valve

1. Clean all parts and inspect for wear or damage. Replace parts as needed.
2. Reassemble in the reverse order, following all notes in the illustration. Put the inlet manifold on first. Be sure the ball checks (6–8) and manifolds (3, 4) are assembled **exactly** as shown. The arrows (A) on the fluid covers (2) **must** point toward the outlet manifold (3).

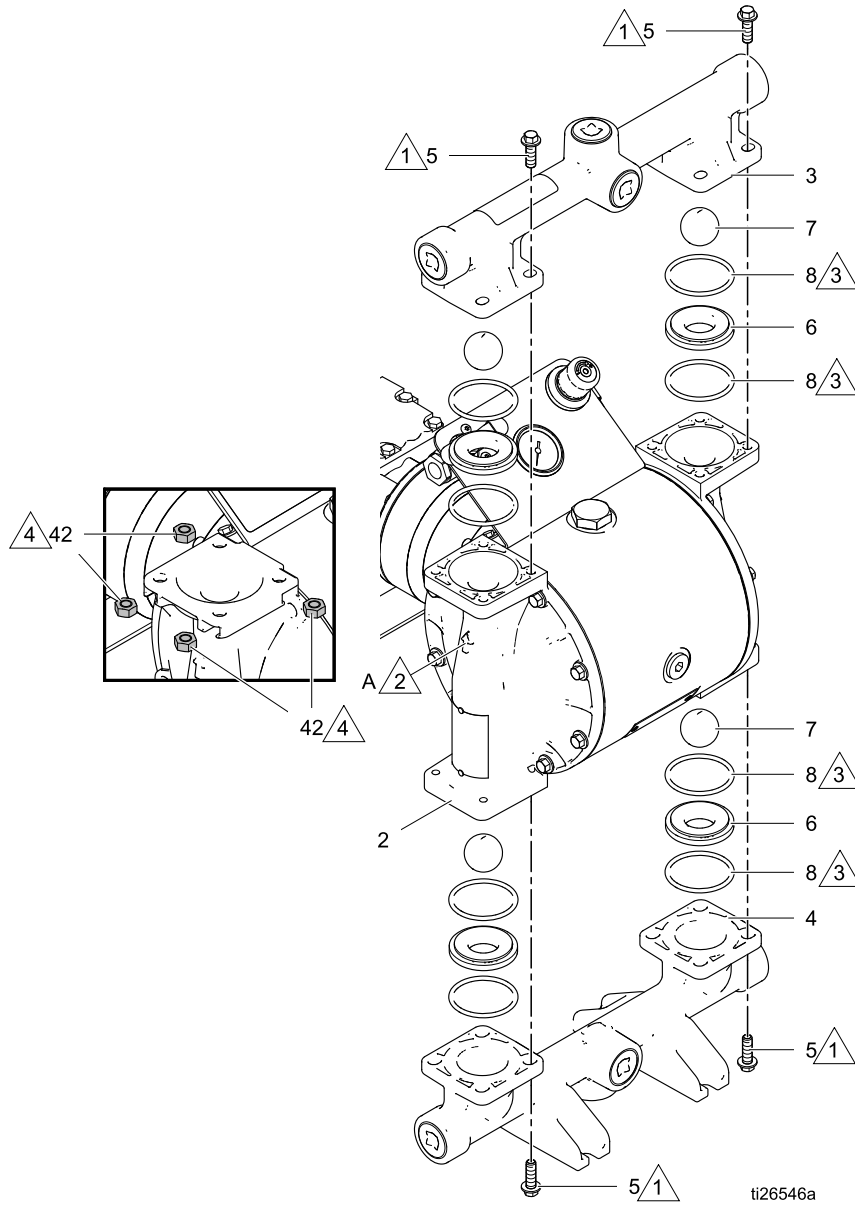
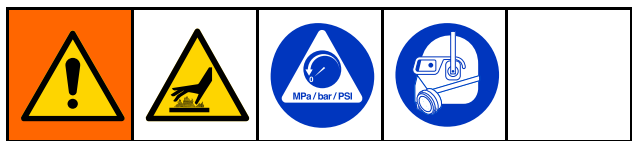

Figure 1 Check valve assembly, aluminum model shown

- △ 1 Apply medium-strength (blue) thread locker. Torque to 10.2 N•m (90 in-lb). Follow torque sequence. See [Torque Instructions, page 23](#).
- △ 2 Arrow (A) must point toward outlet manifold
- △ 3 Not used on some models.
- △ 4 Stainless steel models include nuts (42).

Diaphragm Repair



Disassemble the Diaphragms

NOTE: Diaphragm kits are available in a range of materials and styles. See Parts section.

1. Follow the [Pressure Relief Procedure, page 11](#). Remove power from the motor. Disconnect all hoses.
2. Remove the manifolds and disassemble the ball check valves as explained in [Check Valve Repair, page 11](#).
3. Use a 10 mm socket wrench to remove the bolts (5) from the fluid covers, then pull the fluid covers off of the pump.

TIP: On stainless steel pumps, remove the nuts (42) so they do not fall out and get lost.

4. To remove the diaphragms, the piston must be moved fully to one side. If the pump is not attached to the motor, turn the shaft by hand to move the piston. If the pump is still attached to the motor, loosen the screws and remove the motor fan cover. Turn the fan by hand to rotate the shaft clockwise to shift the piston to one side.
5. **Overmolded Diaphragms (NO and TO models)**

- a. Hold a 16 mm wrench on the wrench flats of the exposed piston shaft. The diaphragm (12) will screw off by hand. Remove the air side diaphragm plate (11).
- b. Rotate the drive shaft to move the piston fully to one side. See instructions in step 4. Repeat step 5a.

6. All Other Diaphragms

- a. **Metal Pumps:** Hold a 16 mm wrench on the wrench flats of the exposed piston shaft. Use another wrench (same size) on the shaft bolt (13) to remove it. Then remove all parts of the diaphragm assembly.
Plastic Pumps: Hold a 16 mm wrench on the wrench flats of the exposed piston shaft. Use a 1-1/4 socket or box end wrench on the hex of the fluid side diaphragm plate to remove it. Then remove all parts of the diaphragm assembly.
- b. Rotate the drive shaft to move the piston fully to one side. See instructions in step 4. Repeat step 6a.

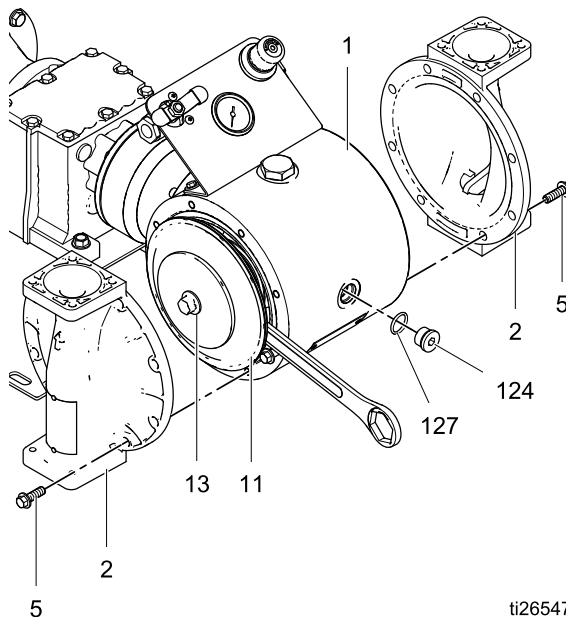

ti26547a

7. To continue with disassembly, see [Disassemble the Center Section, page 16](#).

Reassemble the Diaphragms

Follow all notes in the illustrations on page 15. These notes contain **important** information.

NOTICE

After reassembly, allow the thread locker to cure for 12 hours, or per manufacturer's instructions, prior to operating the pump. Damage to the pump will occur if the diaphragm shaft bolt loosens.

TIP: If you are also repairing or servicing the center section (drive shaft, piston, etc.), see [Center Section Repair, page 16](#), before you put the diaphragms back on.

1. Clean all parts and inspect for wear or damage. Replace parts as needed. Be sure the center section is clean and dry.
2. **Overmolded Diaphragms (NO and TO)**
 - a. If a diaphragm setscrew comes loose or is replaced, apply permanent (red) thread locker to diaphragm side threads. Screw into diaphragm until tight.
 - b. Assemble the air side plate (10) onto the diaphragm. The rounded side of the plate must face the diaphragm.
 - c. Clean the female threads of the piston shaft with a wire brush dipped in solvent to remove any residual thread locker. Apply thread-locking primer and allow it to dry.
 - d. Thoroughly clean, then apply medium-strength (blue) thread locker to the threads of the diaphragm assembly.
 - e. Hold a 16 mm wrench on the wrench flats of the piston shaft. Screw the assembly into the shaft as tight as possible by hand.

TIP: Insert a fluid cover bolt into the center section. Brace the wrench against a bolt and use two hands to tighten the diaphragm. See illustration in [Disassemble the Diaphragms, page 13](#).
 - f. Rotate the drive shaft to move the piston fully to one side. See instructions in step 4 of [Disassemble the Diaphragms, page 13](#).
 - g. Repeat to install the other diaphragm assembly.

3. All Other Diaphragms-Metal Pumps

- a. Thoroughly clean or replace the piston shaft bolt (13). Install the o-ring (34).
- b. Assemble the fluid side plate (9), the diaphragm (11), the backup diaphragm (12, if present), and the air side diaphragm plate (10) on the bolt exactly as shown.
- c. Clean the female threads of the piston shaft with a wire brush dipped in solvent to remove any residual thread locker. Apply thread-locking primer and allow it to dry.
- d. Apply medium-strength (blue) thread locker to the threads of the bolt.
- e. Hold a 16 mm wrench on the wrench flats of the piston shaft. Screw the bolt onto the shaft and torque to 27–34 N•m (20–25 ft-lb).
- f. Rotate the drive shaft to move the piston fully to one side. See instructions in step 4 of [Disassemble the Diaphragms, page 13](#).
- g. Repeat to install the other diaphragm assembly.

4. All Other Diaphragms-Plastic Pumps

- a. Thoroughly clean the threads, or replace the entire fluid side plate (9).
- b. Assemble the diaphragm (11), the backup diaphragm (12, if present), and the air side diaphragm plate (10) on the fluid side plate (9) exactly as shown.
- c. Clean the female threads of the piston shaft with a wire brush dipped in solvent to remove any residual thread locker. Apply thread-locking primer and allow it to dry.
- d. Apply medium-strength (blue) thread locker to the screw threads on the fluid side plate (9).
- e. Hold a 16 mm wrench on the wrench flats of the piston shaft. Screw the assembly into the shaft and torque to 27–34 N•m (20–25 ft-lb).

- f. Rotate the drive shaft to move the piston fully to one side. See instructions in step 4 of [Disassemble the Diaphragms, page 13](#).
- g. Repeat for the other diaphragm assembly.
- 5. Attach the fluid covers. The arrow on each fluid cover must point toward the outlet manifold. Apply medium-strength (blue) thread locker to the bolt threads. See [Torque Instructions, page 23](#), to tighten.
- 6. Reassemble the check valves and manifolds. See [Reassemble the Check Valve, page 11](#).

- △1 Rounded side faces diaphragm.
- △2 Apply medium-strength (blue) thread locker to the threads.
- △3 AIR SIDE markings on diaphragm must face the center housing.
- △4 If the screw comes loose or is replaced, apply permanent (red) thread locker to diaphragm side threads. Apply medium-strength (blue) thread locker to shaft side threads.
- △5 Torque to 27–34 N•m (20–25 ft-lb) at 100 rpm maximum.
- △6 Apply primer to the female threads. Allow to dry.

2-Piece (TF) Models

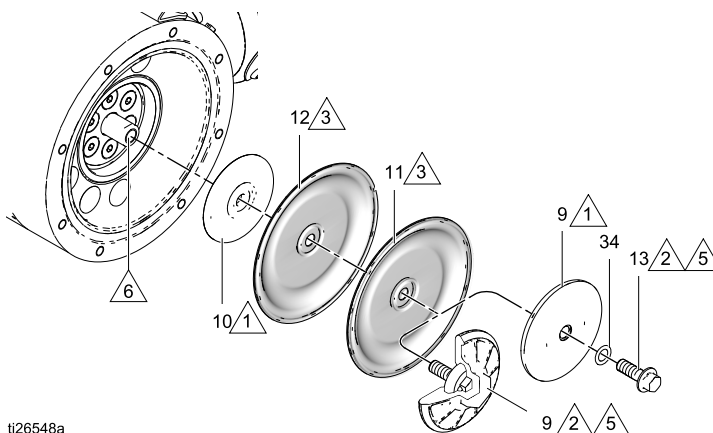

Overmolded (NO and TO) Models

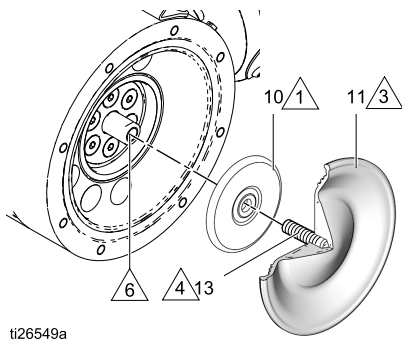

Standard (BN, GE, HY, SP, and VT) Models

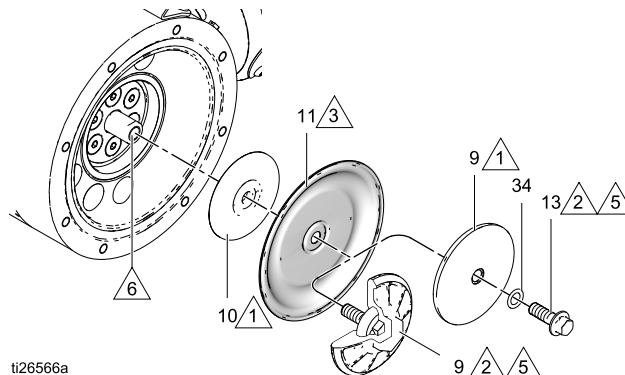

NOTICE

After reassembly, allow the thread locker to cure for 12 hours, or per manufacturer's instructions, prior to operating the pump. Damage to the pump will occur if the diaphragm shaft bolt loosens.

Center Section Repair

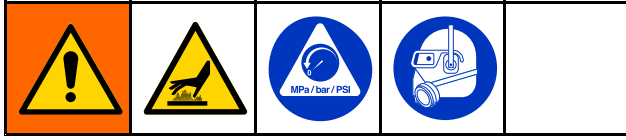

Disassemble the Center Section

See the illustrations on page 18.

1. Follow the [Pressure Relief Procedure, page 11](#). Remove power from the motor. Disconnect all hoses.
2. Remove the manifolds and check valve parts as directed in [Disassemble the Check Valve, page 11](#).
3. Remove the fluid covers and diaphragms as directed in [Disassemble the Diaphragms, page 13](#).
TIP: Clamp the gear box bracket (15) to the bench. Leave the pump connected to the motor.
4. Use a 5 mm hex wrench to remove 4 bolts (117). Pull the pump off of the alignment housing (116).
TIP: It may be necessary to tap the pump with a rubber mallet to disengage the coupler.
5. Use a 5/16 hex wrench to remove the plug (124). Use a 30 mm socket wrench to remove the bearing bolt (106) and the o-ring (108) from the top.
6. Turn the shaft so the groove on the shaft is at the top, in line with the alignment markings.

7. Use a 3/4–16 bolt to push out the drive shaft assembly (112). You can also use the bearing bolt (106), but remove the bearing (107) first. Be sure that the groove on the drive shaft remains aligned with the markings in the center section.

NOTICE

Proper alignment is essential. Do not apply more than about 1.1 N•m (10 in-lb) of torque. Excessive torque could strip the housing thread. If you encounter resistance, check alignment or contact your distributor.

8. The shaft coupler (113) might come out with the drive shaft assembly. If not, reach into the alignment housing (116) and remove the shaft coupler (113).
9. Remove the seal cartridge (110), the o-ring (109) and the radial seal (111) with o-ring (111a) from the drive shaft assembly.
10. Slide the piston assembly (102) out of the center.
11. Leave the gearbox coupler (114) attached to the gearbox shaft (118) unless it is damaged. If you need to remove it, first remove the screws (128) and the access cover (126) on the alignment housing. Turn the gearbox coupler until you have access to screw (115) on the coupler (114). Use an 8 mm hex wrench to remove the screw (115), then remove the gearbox coupler (114).

NOTE: Do not remove the alignment housing (116) from the gearbox unless it is damaged.

Reassemble the Center Section

1. Clean and dry the center housing (101), the center of the piston (102) and the drive shaft (112).
2. Inspect the piston for excessive wear and replace if needed. Grease the piston as shown and install it in the center section with the groove on the top, in line with the alignment markings in the center section.
3. Install the o-ring (108) and the bearing bolt (106). Apply medium-strength (blue) thread locker and torque the bolt to 20–34 N•m (15–25 ft-lb). Be sure that the bearing (107) is in the groove on the piston, as shown. Be sure that the piston moves freely.

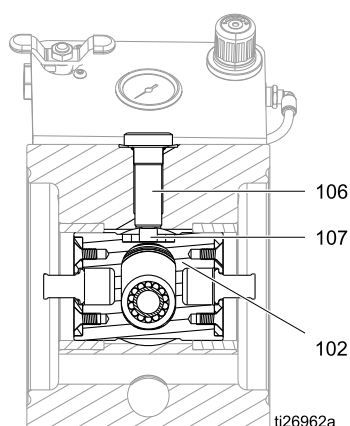

4. Be sure the sealing surface of the drive shaft (112) is clean. Install the seal cartridge (110†) and the radial seal (111†) on the drive shaft. Be sure the o-ring (111a†) is on the radial seal. The lips on the radial seal (111†) must face **IN** toward the center.

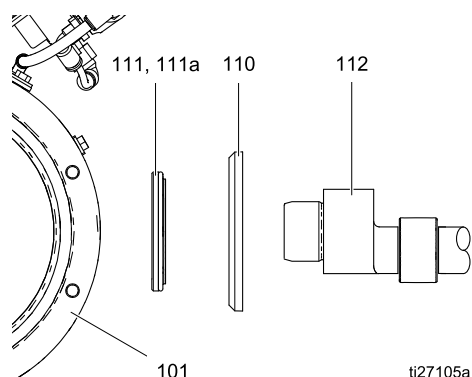

5. Install o-ring (109†).
6. Apply anti-seize lubricant on the mating edges of the drive shaft, as shown in the illustration, page 18.
7. Center the piston in the housing and install the drive shaft assembly (112) into the center housing (101) with the groove facing up.
8. Inspect the shaft coupler (113) for wear and replace if needed. Install on the drive shaft.
9. If removed, install the gearbox coupler (114) in the alignment housing (116) until the coupler seats securely on the shaft. Apply medium strength thread locker and install the screw (115). Torque to 47–61 N•m (35–45 ft-lb). Then install the access cover (126). Torque the screws (128) to 1–2 N•m (10–20 in-lb).
10. Be sure the gearbox coupler (114) is aligned properly. Turn by hand if needed. Connect the pump to the gearbox assembly, engaging the couplers.
11. Apply medium-strength (blue) thread locker and install the housing screws (117). Tighten about 5 turns at a time, in a crisscross pattern, to fully engage the coupler. Torque to 15–18 N•m (130–160 in-lb).
12. Be sure o-ring (127) is on the plug (124). Install the plug and torque to 20–34 N•m (15–25 ft-lb).
13. See [Reassemble the Diaphragms, page 14](#), and [Reassemble the Check Valve, page 11](#).

Repair

- 1 Apply medium-strength (blue) thread locker to threads.
- 2 Torque to 20–34 N•m (15–25 ft-lb).
- 3 Lips must face **IN** toward the center.
- 4 Apply anti-seize lubricant liberally on the radial surfaces of the drive shaft assembly.
- 5 Install the drive shaft assembly with the groove facing up.
- 6 Tighten screws in a crisscross pattern, 5 turns at a time, to engage the coupler evenly. Torque to 15–18 N•m (130–160 in-lb).
- 7 Apply lubricant to inner mating surface.

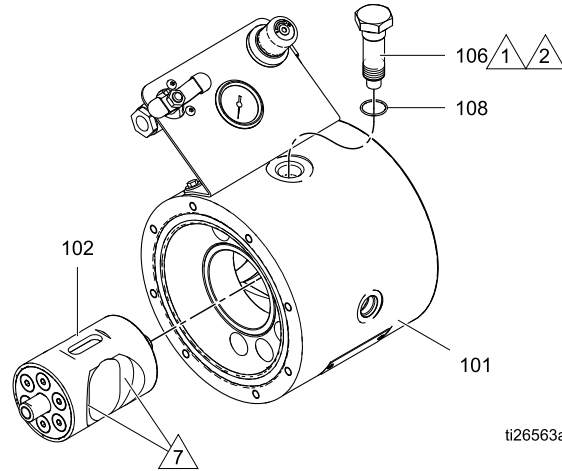

ti26563a

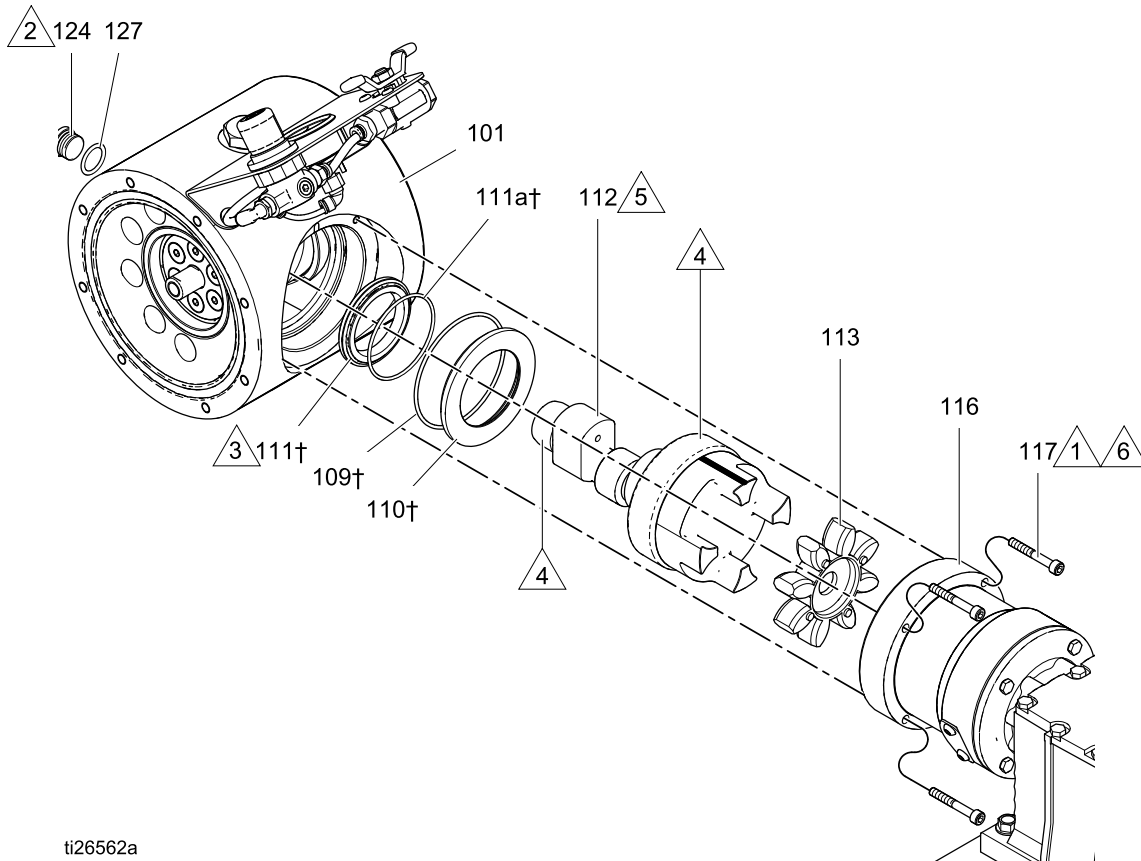

ti26562a

Replace Center Bearing

NOTE: Follow this procedure only if you suspect that the center bearing is damaged. It is not necessary to replace the bearing for normal pump service. You will need Center Section Repair Tool Kit 859.0507. You also will need Bearing Puller Kit 859.0529. The tool (A) was designed to work with this bearing puller.

1. Follow all steps in [Disassemble the Center Section, page 16](#).
2. Clamp the center housing (101) in a vise, with one of the bushings facing up.
3. Place the repair tool (A) on the housing with the grooved side down.
4. Remove the bushing (C). Use the upper holes on the medium-sized jaw, and the inner holes on the puller. Be sure that the jaws engage the bottom rim of the bushing. When one bushing is out, turn the housing over and repeat for the other bushing.

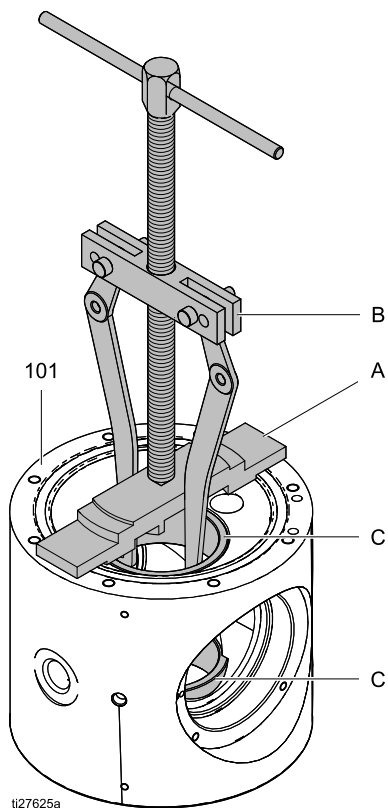

5. Place the center housing (101) in the vise with the bearing (D) side on the bottom.
6. Place the repair tool (A) on the housing with the stepped side down.

7. Remove the bearing (D). Use the lower holes on the medium-sized jaw, and the outer holes on the puller.

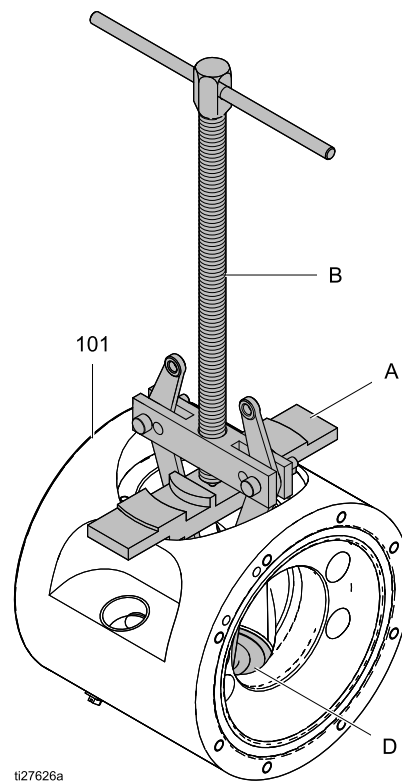

8. Use an arbor press to install the new bearing (D) into the center housing (101). Press the bearing to the shoulder in the center housing.

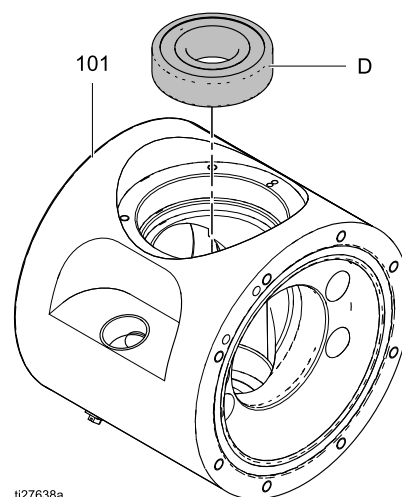

Repair

9. Use an arbor press and the press-fit tool (E) to install the two bushings (C). Install the bushings flush with the center housing (101).

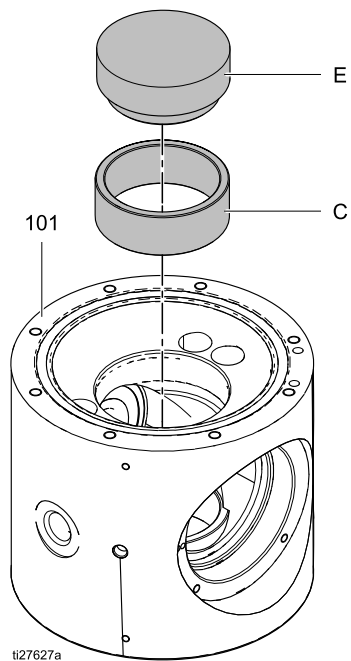

10. Follow all steps in [Reassemble the Center Section, page 17.](#)

Disconnect the Motor and Gearbox

NOTE: Normally, the motor remains connected to the gearbox. Disconnect the motor only if you suspect that the motor or gearbox must be replaced.

TIP: Clamp the gearbox bracket (15) to the bench.

Start at step 1 for ATEX (AX) or Flameproof (AF) motors. Standard AC motors (AC, A1, or A2) are of one piece with the gearbox, so begin with step 3.

1. Use a socket wrench to remove 4 screws (122).

ATEX motors (AX)	15 mm
Flameproof motors (AF)	9/16 in.

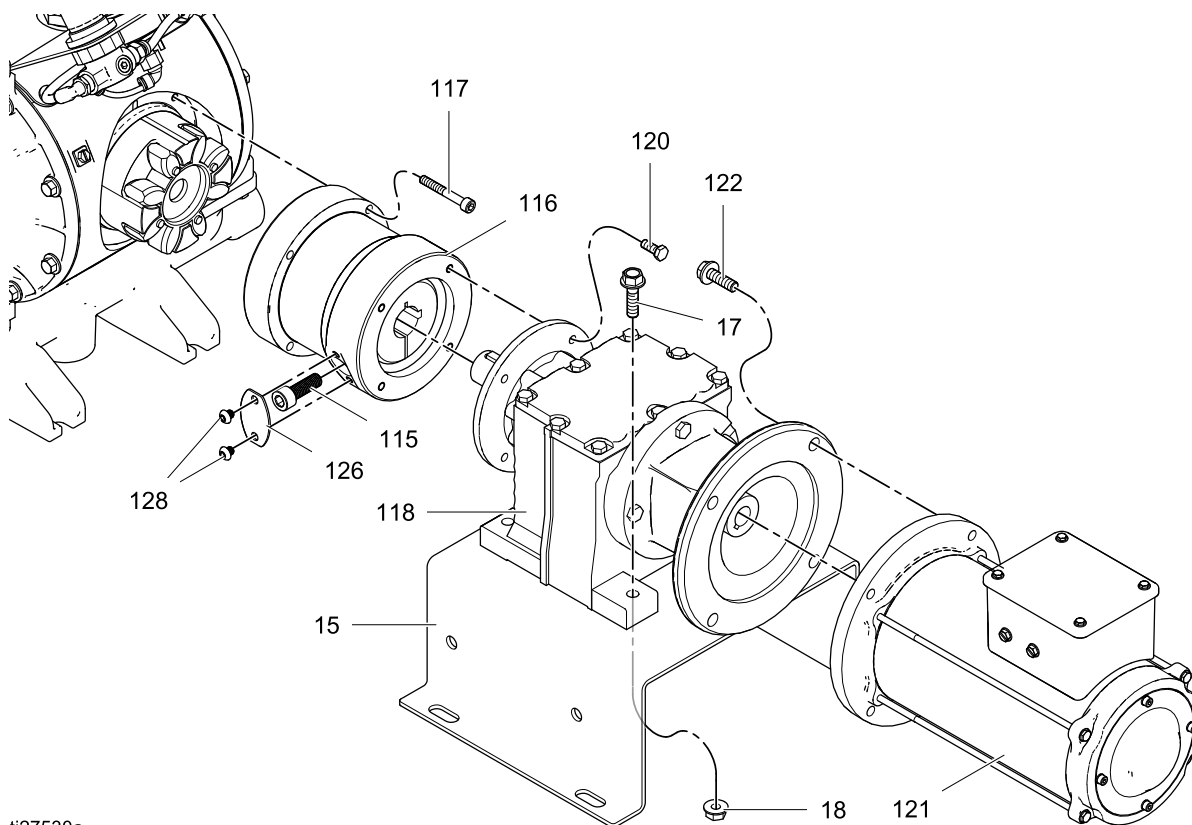

2. Pull the motor (121) straight off of the gearbox (118).

3. Use a 5 mm hex wrench to remove 4 screws (117). Pull the gearbox, with alignment housing (116) attached, off of the pump.
4. Remove the screws (128) and the access cover (126) on the alignment housing. Turn the gearbox coupler (114) until you have access to the screw (115) on the coupler. Use an 8 mm hex wrench to remove the screw (115). Remove the gearbox coupler (114).
5. Use a 10 mm socket wrench to remove 4 screws (120). Pull the alignment housing off of the gearbox.
6. Use a 10 mm socket wrench to remove 4 bolts (17) and nuts (18). Lift the gear box off of the bracket. **NOTE:** If you have an AC motor with gearbox, lift the whole unit off of the bracket.



ti27530a

Replace the Compressor

				
<p>To avoid injury from fire, explosion, or electric shock, all electrical wiring must be done by a qualified electrician and comply with all local codes and regulations.</p>				

1. Follow the [Pressure Relief Procedure](#), page 11.
2. Remove the 8 bolts (203) holding the pump (202) to the mounting surface. Use 2 people or a lift to remove the pump.
3. Tip the pump on its side to provide access to the compressor box.
4. Remove the air line (A1) from the compressor. Disconnect the compressor wires at the terminal block (L1, L2, and ground). Remove the four bolts, and carefully pull the compressor out of the box.
5. Use the four bolts to install the new compressor. Connect the air line from A1 to A1, as shown.
6. Connect the wires from the new compressor to the terminal block, as shown.
7. Return the pump to its mounting location. Secure it with the 8 bolts.
8. Return power to the pump.

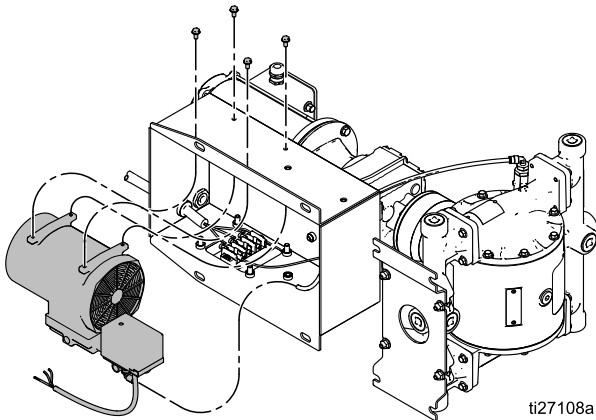
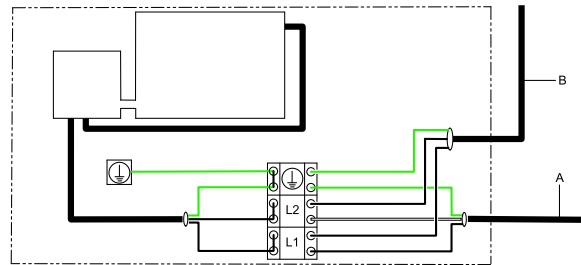
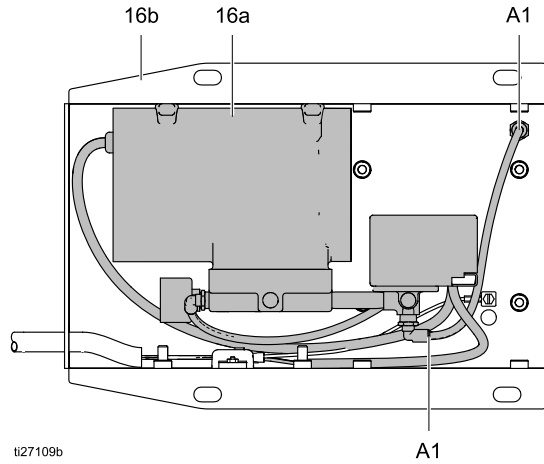

Torque Instructions

If fluid cover or manifold fasteners have been loosened, it is important to torque them using the following procedure to improve sealing.

NOTE: Fluid cover and manifold fasteners have a thread-locking adhesive patch applied to the threads. If this patch is excessively worn, the fasteners may loosen during operation. Replace screws with new ones or apply medium-strength (blue) Loctite or equivalent to the threads.

NOTE: Always completely torque fluid covers before torquing manifolds.

1. Start all fluid cover screws a few turns. Then, turn down each screw just until head contacts cover.
2. Turn each screw by 1/2 turn or less working in a crisscross pattern in the order shown to specified torque.
3. Repeat for manifolds.

Fluid cover and manifold fasteners: 10.2 N•m (90 in-lb)

Fluid Cover Screws

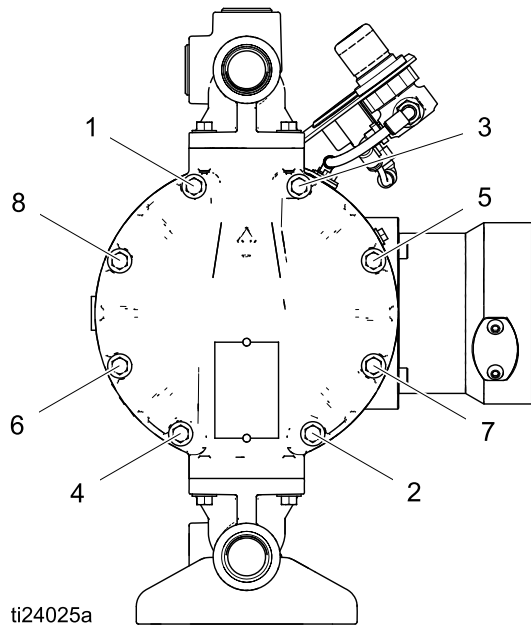

Inlet and Outlet Manifold Screws

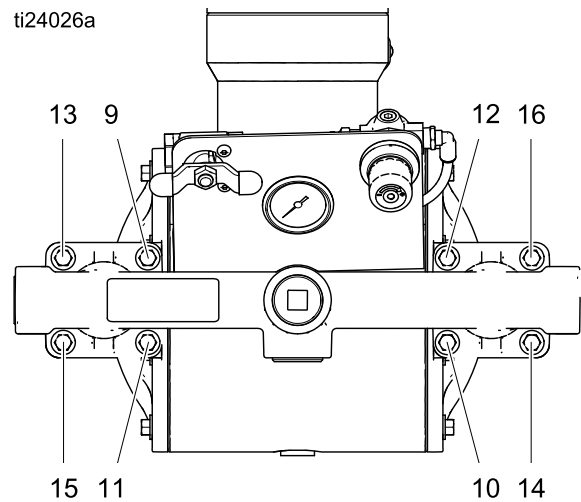

Parts

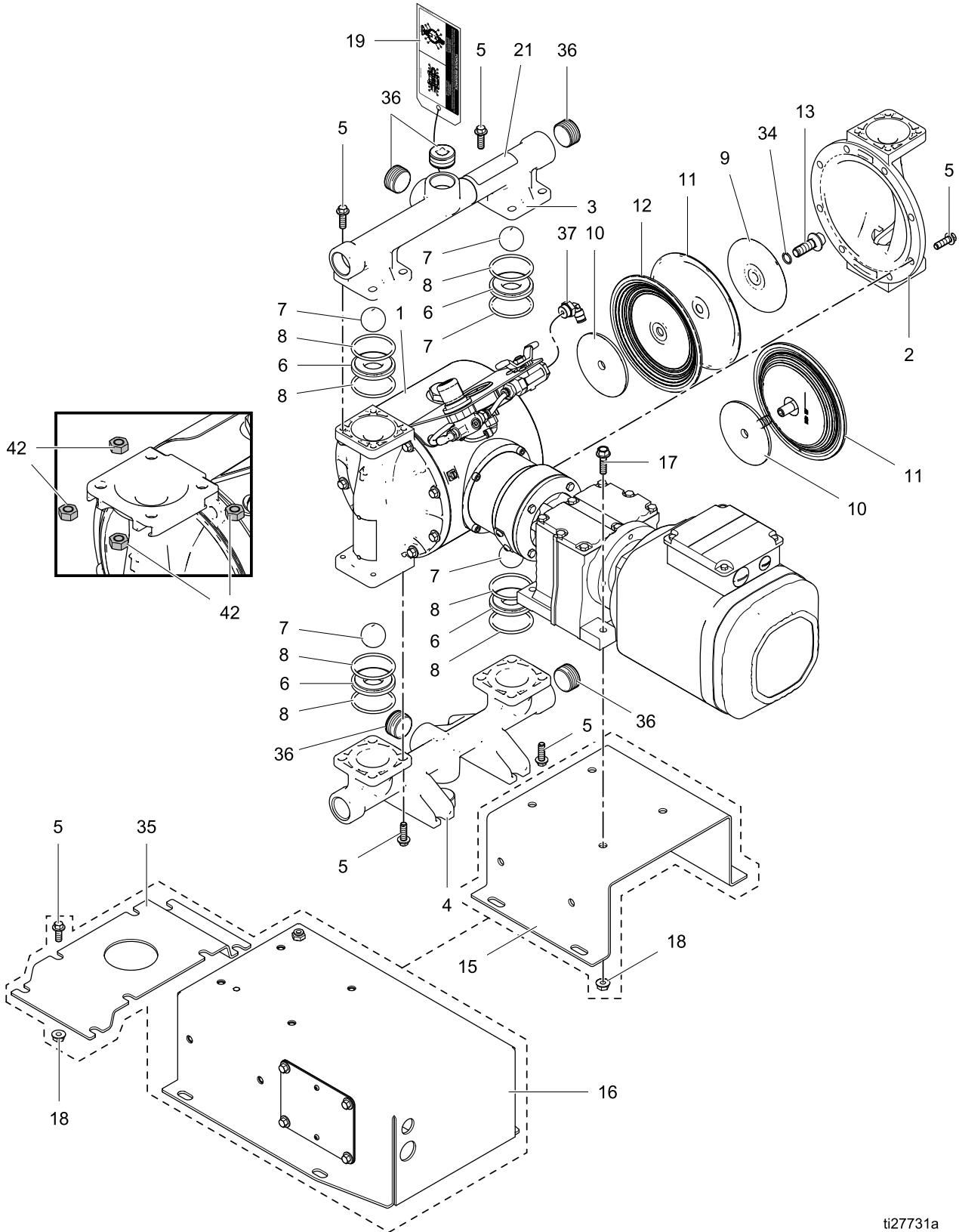

ti27731a

Parts/Kits Quick Reference

Use this table as a quick reference for parts/kits. Go to the pages indicated in the table for a full description of kit contents.

Ref.	Part/Kit	Description	Qty.
1	---	MODULE, drive; <i>See page 29.</i>	1
2	859.0032 859.0070 859.0081	COVER, fluid; <i>See page 27.</i> Aluminum Polypropylene Stainless Steel	2
3	859.0028 859.0029 859.0058 859.0061 859.0077 859.0078	MANIFOLD, outlet; <i>See pages 27-28</i> Aluminum, npt Aluminum, bspt Polypropylene, center flange Polypropylene, end flange Stainless Steel, npt Stainless Steel, bspt	1
4	859.0030 859.0031 859.0064 859.0067 859.0079 859.0080	MANIFOLD, inlet; <i>See pages 27-28</i> Aluminum, npt Aluminum, bspt Polypropylene, center flange Polypropylene, end flange Stainless Steel, npt Stainless Steel, bspt	1
5	859.0033 859.0076 859.0084	FASTENERS, manifold and fluid cover; 8-pack; <i>see page 28</i> Aluminum fluid section Polypropylene fluid section Stainless Steel fluid section	2 pkg

Ref.	Part/Kit	Description	Qty.
6	859.0009 859.0010 859.0011 859.0017 859.0012 859.0014 859.0015 859.0016 859.0753 859.0013	SEAT; 4-pack, includes 8 o-rings where needed; <i>See page 31.</i> Acetal Aluminum Buna-N FKM Fluoroelastomer Geolast Polypropylene Santoprene 316 Stainless Steel (metal pumps) 316 Stainless Steel (plastic pumps) TPE	1 pkg
7	859.0018 859.0019 859.0022 859.0023 859.0027 859.0020 859.0024 859.0025 859.0026 859.0021	BALLS, check; 4-pack, includes 8 o-rings; <i>See page 31.</i> Acetal Buna-N Polychloroprene Polychloroprene with SST core FKM Fluoroelastomer Geolast PTFE Santoprene 316 Stainless Steel TPE	1 pkg
8	859.0034	O-RING, manifold, (not used on some models); PTFE, 8-pack; <i>See page 31.</i>	1 pkg
9	---	PLATE, fluid side; included in Air and Fluid Plate Kits; <i>See page 33.</i>	2
10	---	PLATE, air side; included in air and Fluid Plate Kits; <i>See page 33.</i>	2

Parts

Ref.	Part/Kit	Description	Qty.
11		DIAPHRAGM, kit; <i>See page 32-33.</i>	1 kit
	859.0001	Buna-N Standard	
	859.0008	FKM Fluoroelastomer Standard	
	859.0002	Geolast Standard	
	859.0007	Santoprene Standard	
	859.0003	TPE Standard	
	859.0004	Polychloroprene Overmolded	
	859.0005	PTFE/EPDM Overmolded	
	859.0006	PTFE/EPDM Two-Piece	
12	---	DIAPHRAGM, backup, <i>included with Ref. 11 where needed</i>	2
13	859.0085	BOLT, shaft; kit; <i>includes Ref. 34</i>	2
15		BRACKET, gear box, for models without compressor; includes refs 17 and 18	1
	859.0498	for aluminum fluid section	
	859.0500	for polypropylene fluid section	
	859.0499	for stainless steel fluid section	
16		COMPRESSOR, assembly; <i>includes Refs. 16a, 16b, 18, and 35</i>	1
	859.0502	120 Volt	
	859.0501	240 Volt	
16a		COMPRESSOR	1
	859.0504	120 Volt	
	859.0505	240 Volt	

Ref.	Part/Kit	Description	Qty.
16b	---	BOX, compressor	1
17	---	BOLT, hex washer head, M8-1.25 x 32 mm; <i>included with Ref. 15</i>	4
18	---	NUT; <i>included with Ref. 15 or 16</i>	4
19▲		TAG, torque	1
	859.0515	for aluminum and stainless steel fluid sections	
	859.0516	for polypropylene fluid sections	
21▲	859.0527	LABEL, warning	1
34	---	O-RING, for diaphragm shaft bolt; <i>included with Ref. 13</i>	2
35		BRACKET, riser; <i>used for models with a compressor</i>	1
	859.0525	for aluminum center section	
	859.0524	for stainless steel center section	
36	859.0105	PLUG; 6-pack, <i>used for models with aluminum fluid section</i>	1 pkg
37	---	ELBOW, male, swivel, 3/8 npt(f) x 1/4T; <i>used for models with a compressor</i>	1
42	---	NUT, manifold; Qty. 8; <i>included in kit 859.0084</i>	2 pkg

--- Not sold separately.

▲ Replacement Warning labels, signs, tags, and cards are available at no cost.

Fluid Covers and Manifolds

Sample Configuration Number							
Pump Model	Fluid Section Material	Drive Section Material	Seats	Balls	Diaphragms	Connections	Options
VA-E25	A	A	HY	AC	HY	TB	AC

Fluid Cover Kits		
Kits include: 1 fluid cover (2) 4 o-rings (8)		
Aluminum		
A	859.0032	<p>ti16906a</p>
Polypropylene		
P	859.0070	<p>ti26891a</p>
Stainless Steel		
S	859.0081	<p>ti26890a</p>

NOTE: Outlet manifolds include a Warning label. Replacement warning labels, signs, tags, and cards are available at no cost.

Aluminum Manifold Kits	
Kits include: 1 manifold (3) 3 plugs (36) 4 o-rings (8) 1 safety label (outlet manifolds only; ▲21)	
Outlet (3)	
A...TN	859.0028
A...TB	859.0029
<p>ti14307a</p>	
Inlet (4)	
A...TN	859.0030
A...TB	859.0031
<p>ti14308a</p>	

Parts

Sample Configuration Number							
Pump Model	Fluid Section Material	Drive Section Material	Seats	Balls	Diaphragms	Connections	Options
VA-E25	A	A	HY	AC	HY	TB	AC

Polypropylene Kits		
Kits include: 1 manifold (3) 4 o-rings (8) 1 safety label (outlet manifolds only; ▲21)		
Center Flange Outlet (3)		
P...FC	859.0058	
End Flange Outlet (3)		
P...FE	859.0061	
Center Flange Inlet (4)		
P...FC	859.0064	
End Flange Inlet (4)		
P...FE	859.0067	

Stainless Steel		
Kits include: 1 manifold (3) 4 o-rings (8) 1 safety label (outlet manifolds only; ▲21)		
Outlet (3)		
S...TN	859.0077	
A...TB	859.0078	
Inlet (4)		
S...TN	859.0079	
S...TB	859.0080	
Manifold/Fluid Cover Fastener Kits		
Aluminum Fluid Section		859.0033
Kit includes: • 8 bolts; carbon steel, hex washer head; M8 x 25		
Polypropylene Fluid Section		859.0076
Kit includes: • 8 bolts, 300 series stainless steel; hex flange, M8 x 32 • 8 nuts		
Stainless Steel Fluid Section		859.0084
Kit includes: • 8 bolts, 300 series stainless steel; hex washer head, M8 x 20 • 8 nuts		

Drive Section

Sample Configuration Number							
Pump Model	Fluid Section Material	Drive Section Material	Seats	Balls	Diaphragms	Connections	Options
VA-E25	A	A	HY	AC	HY	TB	AC

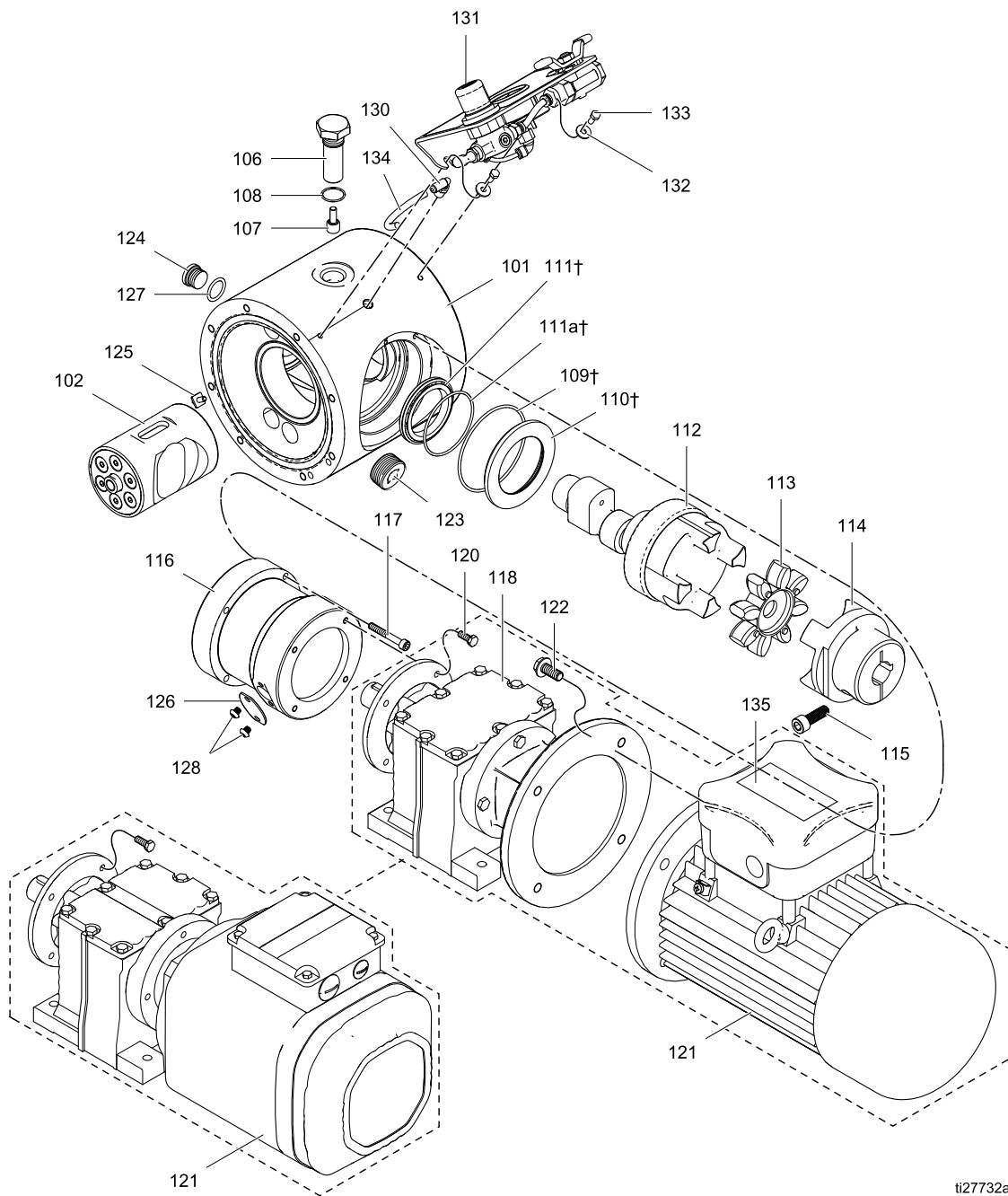

ti27732a

Parts

Ref	Part	Description	Qty
101	859.0486 859.0487	HOUSING, center, assembly; <i>includes plugs (Refs. 123, 124)</i> Aluminum (A) Stainless Steel (S); <i>also includes o-ring (Ref. 127)</i>	1
102	859.0509	PISTON, assembly	1
106	859.0493 859.0494	BOLT, bearing; <i>includes Refs. 107 and 108</i> for aluminum center housing (A) for stainless steel center housing (S)	1
107	— — —	BEARING, cam follower. <i>included with Ref. 106</i>	1
108	— — —	O-RING, Size 019, Fluoroelastomer; <i>included with Ref. 106</i>	1
109†	— — —	O-RING, Size 153, Buna-N; <i>included with Ref. 112</i>	1
110†	— — —	CARTRIDGE, seal	1
111†	— — —	SEAL, radial	1
111a†	— — —	O-RING, radial seal	1
112	859.0485	SHAFT, drive, assembly; <i>includes o-ring (Ref. 109), cartridge (Ref. 110) and seal (Ref. 111)</i>	1
113	859.0484	COUPLER, shaft	1
114	859.0483	COUPLER, gearbox; <i>includes screw (Ref. 115)</i>	1
115	— — —	SCREW, socket head, M10 x 30 mm ; <i>included with Ref. 114</i>	1
116	859.0488 859.0489	HOUSING, alignment, assembly; <i>includes screws (Refs. 117, 128) and access cover (Ref. 126)</i> Aluminum (A) Stainless steel (S)	1
117	— — —	SCREW, socket head, M6 x 40 mm; <i>included with Ref. 116</i>	4

Ref	Part	Description	Qty
118	859.0520 859.0521	GEARBOX IEC, 90 B5 Flange; used on IG models NEMA, 56 C; used on NG and AF models	1
120	— — —	SCREW, cap, hex head, M6 x 16 mm	4
121	859.0482 859.0523 859.0522	MOTOR AC, includes gearbox, used on BC, B1, and B2 models ATEX; used on AX models EX; used on AF models	1
122	— — —	SCREW, cap, hex head, 5/16 x 1; used on AF models	4
123	859.0526	PLUG, pipe, headless	1
124	859.0495	PLUG, front access, includes o-ring (Ref. 127) where needed	1
125	— — —	SCREW, ground, M5 x 0.8	1
126	859.0491	COVER, access; <i>includes screws (Ref. 128)</i>	1
127	— — —	O-RING, <i>included with Ref. 124</i>	1
128	— — —	SCREW, button head, M6 x 6 mm; <i>included in Refs. 116 and 126</i>	2
130	— — —	ELBOW, 1/8–27 npt; <i>included with Ref. 131</i>	1
131	859.0492	CONTROLS, air, <i>includes elbow (Ref. 130), washer (Ref. 132), tubing, and screw (Ref. 133)</i>	1
132	— — —	WASHER; <i>included with Ref. 131</i>	1
133	— — —	SCREW; <i>included with Ref. 131</i>	1

— — — Not sold separately.

† Included in Shaft Seal Repair Kit 859.0496.

Seats and Check Balls

<i>Sample Configuration Number</i>							
Pump Model	Fluid Section Material	Drive Section Material	Seats	Balls	Diaphragms	Connections	Options
VA-E25	A	A	HY	AC	HY	TB	AC

Seat Material		Kit
AC	Acetal	859.0009
AL	Aluminum	859.0010
BN	Buna-N (o-ring not used)	859.0011
GE	Geolast	859.0012
HY	TPE (o-ring not used)	859.0013
PP	Polypropylene	859.0014
SP	Santoprene	859.0015
SS	Stainless Steel:	
	metal pumps	859.0016
	plastic pumps	859.0753
VT	FKM Fluoroelastomer (o-ring not used)	859.0017

Kits include:

- 4 seats (6), material indicated in table.
- 8 o-rings (8), PTFE, not used on models with Buna-N, FKM, or TPE seats.

O-Ring Kit

Seat Material	Kit
AC, AL, GE, PP, SP, SS	859.0034

Ball Material		Kit
AC	Acetal	859.0018
BN	Buna-N	859.0019
FK	FKM Fluoroelastomer	859.0027
GE	Geolast	859.0020
HY	TPE	859.0021
NE	Polychloroprene	859.0022
NW	Polychloroprene weighted with stainless steel	859.0023
TF	PTFE	859.0024
SP	Santoprene	859.0025
SS	Stainless Steel	859.0026

Kits include:

- 4 balls (7), material indicated in table.
- 8 o-rings (8); not used on models with Buna-N, FKM, or TPE seats.

Diaphragms

Sample Configuration Number							
Pump Model	Fluid Section Material	Drive Section Material	Seats	Balls	Diaphragms	Connections	Options
VA-E25	A	A	HY	AC	HY	TB	AC

1-Piece Bolt-Through Diaphragm Material		Kit
BN	Buna-N	859.0001
GE	Geolast	859.0002
HY	TPE	859.0003
SP	Santoprene	859.0007
VT	FKM Fluoroelastomer	859.0008

Kits include:

- 2 diaphragms (11), material indicated in table
- 2 o-rings (34); used on metal pumps
- 1 diaphragm install tool; not used
- 8 o-rings (8); not used on models with Buna-N, FKM, or TPE seats.

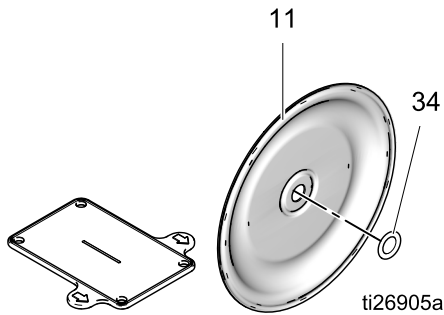

Overmolded Diaphragm Material		Kit
NO	Polychloroprene	859.0004
TO	PTFE/EPDM	859.0005

Kits include:

- 2 overmolded diaphragms (11), material indicated in table.
- 2 diaphragm set screws (13)
- 1 diaphragm install tool; not used
- 1 packet anaerobic adhesive
- 1 packet sealant

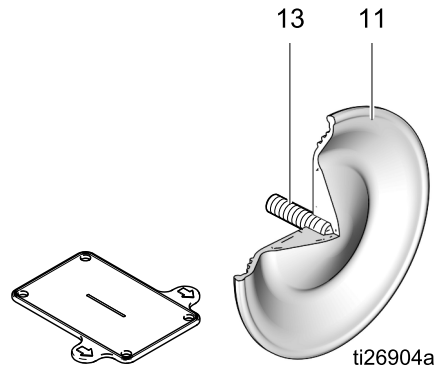

Sample Configuration Number							
Pump Model	Fluid Section Material	Drive Section Material	Seats	Balls	Diaphragms	Connections	Options
VA-E25	A	A	HY	AC	HY	TB	AC

2-Piece Bolt-Through Diaphragm Kit		
TF	PTFE and EPDM	859.0006

Kits include:

- 2 diaphragms (11), PTFE
- 2 backup diaphragms (12), material indicated in table
- 2 o-rings (34); used on metal pumps
- 1 diaphragm install tool; not used
- 8 o-rings (8); PTFE

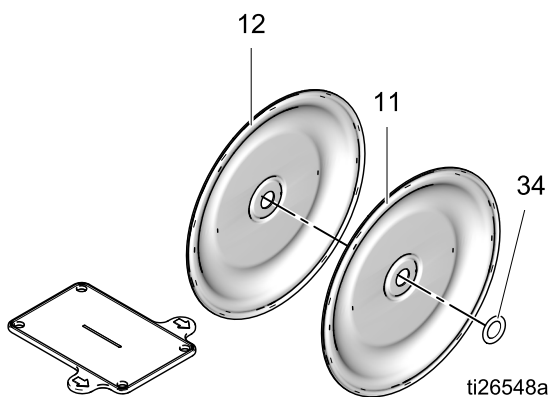

Diaphragm Shaft Bolt	
Metal Pumps	859.0085

Kits include:

- 1 bolt (13); stainless steel, M12 x 35
- 1 o-ring (34)

Air and Fluid Plate Kits

Fluid Section Material	Kit
Aluminum	859.0055
Polypropylene	859.0056
Stainless Steel	859.0082

Kits for aluminum and stainless steel pumps include:

- 1 air side diaphragm plate (10)
- 1 fluid side diaphragm plate (9)
- 1 o-ring (34)
- 1 bolt (13)

Kits for polypropylene pumps include:

- 1 air side diaphragm plate (10)
- 1 fluid side diaphragm plate (9, includes bolt)

Seat, Check Ball, and Diaphragm Kits

Sample Configuration Number							
Pump Model	Fluid Section Material	Drive Section Material	Seats	Balls	Diaphragms	Connections	Options
VA-E25	A	A	HY	AC	HY	TB	AC

Kit	Parts	Qty
859.0131 (PP, TF, TF)	SEAT, polypropylene	4
	O-RING, PTFE	8
	BALL, PTFE	4
	O-RING	2
	DIAPHRAGM, PTFE	2
	DIAPHRAGM, EPDM	2
	TOOL, install	1
859.0132 (PP, TF, TO)	SEAT, polypropylene	4
	O-RING, PTFE	8
	BALL, PTFE	4
	ADHESIVE	1
	SCREW	2
	DIAPHRAGM, PTFE Overmolded	2
	TOOL, install	1
859.0133 (PP, BN, BN)	SEAT, polypropylene	4
	O-RING, PTFE	8
	BALL, buna-N	4
	O-RING	2
	DIAPHRAGM, buna-N	2
	TOOL, install	1
859.0134 (PP, SP, SP)	SEAT, polypropylene	4
	O-RING, PTFE	8
	BALL, santoprene	4
	O-RING	2
	DIAPHRAGM, santoprene	2
	TOOL, install	1
859.0135 (PP, VT, VT)	SEAT, polypropylene	4
	O-RING, PTFE	8
	BALL, FKM	4
	O-RING	2
	DIAPHRAGM, FKM	2
	TOOL, install	1

Kit	Parts	Qty
859.0139 (HY, AC, HY)	SEAT, TPE	4
	BALL, acetal	4
	O-RING	2
	DIAPHRAGM, TPE	2
	TOOL, install	1
859.0140 (KY, TF, TF)	SEAT, PVDF	4
	O-RING, PTFE	8
	BALL, PTFE	4
	O-RING	2
	DIAPHRAGM, PTFE	2
	DIAPHRAGM, EPDM	2
859.0141 (KY, TF, TO)	SEAT, PVDF	4
	O-RING, PTFE	8
	BALL, PTFE	4
	ADHESIVE	1
	SCREW	2
	DIAPHRAGM, PTFE Overmolded	2
	TOOL, install	1
859.0142 (GE, GE, GE)	SEAT, geolast	4
	O-RING, PTFE	8
	BALL, geolast	4
	O-RING	2
	DIAPHRAGM, geolast'	2
	TOOL, install	1
859.0143 (AL, BN, BN)	SEAT, aluminum	4
	O-RING, PTFE	8
	BALL, buna-N	4
	O-RING	2
	DIAPHRAGM, buna-N	2
	TOOL, install	1

Kit	Parts	Qty
859.0144 (AL, GE, GE)	SEAT, aluminum	4
	O-RING, PTFE	8
	BALL, geolast	4
	O-RING	2
	DIAPHRAGM, geolast'	2
	TOOL, install	1
859.0145 (AL, SP, SP)	SEAT, aluminum	4
	O-RING, PTFE	8
	BALL, santoprene	4
	O-RING	2
	DIAPHRAGM, santoprene	2
	TOOL, install	1
859.0146 (AL, TF, TO)	SEAT, aluminum	4
	O-RING, PTFE	8
	BALL, PTFE	4
	ADHESIVE	1
	SCREW	2
	DIAPHRAGM, PTFE Overmolded	2
	TOOL, install	1
859.0147 (AL, TF, TF)	SEAT, aluminum	4
	O-RING, PTFE	8
	BALL, PTFE	4
	O-RING	2
	DIAPHRAGM, PTFE	2
	DIAPHRAGM, EPDM	2
	TOOL, install	1
859.0148 (SP, SP, SP)	SEAT, santoprene	4
	O-RING, PTFE	8
	BALL, santoprene	4
	O-RING	2
	DIAPHRAGM, santoprene	2
	TOOL, install	1
859.0149 (VT, VT, VT)	SEAT, FKM	4
	BALL, FKM	4
	O-RING	2
	DIAPHRAGM, FKM	2
	TOOL, install	1

Kit	Parts	Qty
SS, BN, BN 859.0136 (metal pumps)	SEAT, stainless steel	4
	O-RING, PTFE	8
	BALL, buna-N	4
	O-RING	2
859.0754 (plastic pumps)	DIAPHRAGM, buna-N	2
	TOOL, install	1
SS, TF, TF 859.0137 (metal pumps)	SEAT, stainless steel	4
	O-RING, PTFE	8
	BALL, PTFE	4
	O-RING	2
	DIAPHRAGM, PTFE	2
	DIAPHRAGM, EPDM	2
859.0755 (plastic pumps)	TOOL, install	1
	SS, TF, TO 859.0138 (metal pumps)	SEAT, stainless steel
O-RING, PTFE		8
BALL, PTFE		4
ADHESIVE		1
SCREW		2
DIAPHRAGM, PTFE Overmolded		2
859.0756 (plastic pumps)	TOOL, install	1
	SS, SP, SP 859.0251 (metal pumps)	SEAT, 316 stainless steel
O-RING, PTFE		8
BALL, santoprene		4
O-RING		2
DIAPHRAGM, santoprene		2
TOOL, install		1
859.0757 (plastic pumps)	SEAT, stainless steel	4
	O-RING, PTFE	8
	BALL, polychlorprene	4
	O-RING	2
859.0416 (metal pumps)	DIAPHRAGM, buna-N	2
	TOOL, install	1
859.0758 (plastic pumps)	SEAT, stainless steel	4
	O-RING, PTFE	8
SS, NW, BN 859.0417 (metal pumps)	BALL, polychlorprene	4
	O-RING, PTFE	2
	ADHESIVE	2
	SCREW	2
	DIAPHRAGM, polychlorprene Overmolded	2
	TOOL, install	1
859.0759 (plastic pumps)	TOOL, install	1

Parts

Kit	Parts	Qty
SS, SS, TF	SEAT, stainless steel	4
	O-RING, PTFE	8
859.0418 (metal pumps)	BALL, stainless steel	4
	O-RING	2
859.0760 (plastic pumps)	DIAPHRAGM, PTFE	2
	DIAPHRAGM, EPDM	2
	TOOL, install	1

Kits and Accessories

Leak Sensor Kit 859.0508

Upgrade kit, to add a leak sensor to an existing system. Includes leak sensor and bushing.

NOTE: Also purchase a cable from the following selections.

Leak Sensor Cables; Field Wireable (for VFDs)

M8, 4-pin

Part	Description
859.0517	9.8 ft; 3.0 m
859.0518	24.6 ft; 7.5 m
859.0519	52.5 ft; 16 m

Compressor Upgrade Kits 859.0502 (120V) and 859.0501 (240V)

Upgrade kits include compressor, compressor box, brackets, and mounting hardware.

Center Section Repair Tool Kit 859.0507

Includes tools needed to remove the bearing from the center section.

Bearing Puller Kit 859.0529

Includes an interchangeable bearing puller set.

Technical Data

	US	Metric
VERDERAIR VA-E25 Electric Double Diaphragm Pump		
Maximum fluid working pressure	70 psi	0.48 MPa, 4.8 bar
Maximum incoming air pressure	150 psi	1.03 MPa, 10.3 bar
Center section air charge range	20 to 80 psi	0.14–0.55 MPa, 1.4–5.5 bar
Maximum air consumption	<0.2 scfh	<0.006 cubic meters/hour
Air inlet size	3/8 in. npt(f)	
Maximum suction lift (reduced if balls don't seat well due to damaged balls or seats, lightweight balls, or extreme speed of cycling)	Wet: 29 ft Dry: 16 ft	Wet: 8.8 m Dry: 4.9 m
Maximum size pumpable solids	1/8 in.	3.2 mm
Ambient air temperature range for operation and storage. NOTE: Exposure to extreme low temperatures may result in damage to plastic parts.	32° F–104° F	0° C–40° C
Fluid displacement per cycle	0.14 gallons	0.53 liters
Maximum free-flow delivery	39 gpm	148 lpm
Maximum pump speed	280 cpm	
Fluid Inlet and Outlet Size		
Aluminum or Stainless Steel	1 in npt(f) or 1 in bspt	
Polypropylene	1 in. ANSI/DIN Raised Face Flange	
Electric Motor		
AC, Standard CE (BC, B1, B2)		
Power	2 HP	1.5 kW
Speed	1800 rpm (60 Hz) or 1500 rpm (50 Hz)	
Gear Ratio	8.16	
Voltage	3-phase 230V / 3-Phase 460V	
AC, ATEX (AX)		
Power	2 HP	1.5 kW
Speed	3420 rpm (60 Hz) or 2850 rpm (50 Hz)	
Gear Ratio	18.08	
Voltage	3-phase 240V / 3-Phase 415V	

	US	Metric
AC, Explosionproof (AF)		
Power	2 Hp	1.5 kW
Speed	3450 rpm (60 Hz) or 2875 rpm (50 Hz)	
Gear Ratio	18.08	
Voltage	3-phase 230V / 3-Phase 460V	
Noise Data		
Sound Power (measured per ISO-9614-2)		
at 70 psi fluid pressure and 50 cpm	71 dBa	
at 30 psi fluid pressure and 280 cpm (full flow)	94 dBa	
Sound Pressure [tested 3.28 ft (1 m) from equipment]		
at 70 psi fluid pressure and 50 cpm	61 dBa	
at 30 psi fluid pressure and 280 cpm (full flow)	84 dBa	
Wetted Parts		
Wetted parts include material(s) chosen for seat, ball, and diaphragm options, plus the fluid section's material of construction: Aluminum, Polypropylene, or Stainless Steel		
Non-wetted parts		
Aluminum	aluminum, coated carbon steel, bronze	
Polypropylene	stainless steel, polypropylene, coated carbon steel, bronze	
Stainless Steel	stainless steel, aluminum, coated carbon steel, bronze	

Weights (typical only)

Pump Material		Motor/Gearbox									
Fluid Section	Center Section	AC Induction (BC)		ATEX (AX)		Flameproof (AF)		NEMA (NG)		IEC (IG)	
		lb	kg	lb	kg	lb	kg	lb	kg	lb	kg
Aluminum	Aluminum	106	48.1	144	65.3	109.5	49.7	69.5	31.5	74	33.6
Polypropylene	Aluminum	103.5	46.9	141.5	64.2	106.5	48.3	67	30.4	71.5	32.4
Polypropylene	Stainless Steel	135	61.2	173	78.5	138.5	62.8	98.5	44.7	103	46.7
Stainless Steel	Aluminum	121.5	55.1	159.5	72.3	125	55.5	85	38.6	89.5	40.6
Stainless Steel	Stainless Steel	153	69.4	191	86.6	156.5	71.0	116.5	52.8	121	54.9

Component	U.S.	Metric
Compressor	28 lb	13 kg

Fluid Temperature Range

NOTICE

Temperature limits are based on mechanical stress only. Certain chemicals will further limit the fluid temperature range. Stay within the temperature range of the most-restricted wetted component. Operating at a fluid temperature that is too high or too low for the components of your pump may cause equipment damage.

Diaphragm/Ball/Seat Material	Fluid Temperature Range			
	Aluminum or Stainless Steel Pumps		Polypropylene Pumps	
	Fahrenheit	Celsius	Fahrenheit	Celsius
Acetal (AC)	10° to 180°F	-12° to 82°C	32° to 150°F	0° to 66°C
Buna-N (BN)	10° to 180°F	-12° to 82°C	32° to 150°F	0° to 66°C
FKM Fluoroelastomer (VT)*	-40° to 275°F	-40° to 135°C	32° to 150°F	0° to 66°C
Geolast® (GE)	-40° to 150°F	-40° to 66°C	32° to 150°F	0° to 66°C
Polychloroprene overmolded diaphragm (NO) or Polychloroprene check balls (NE or NW)	0° to 180°F	-18° to 82°C	32° to 150°F	0° to 66°C
Polypropylene (PP)	32° to 150°F	0° to 66°C	32° to 150°F	0° to 66°C
PTFE overmolded diaphragm (TO)	40° to 180°F	4° to 82°C	40° to 150°F	4° to 66°C
PTFE check balls or two-piece PTFE/EPDM diaphragm (TF)	40° to 220°F	4° to 104°C	40° to 150°F	4° to 66°C
Santoprene® check balls (SP)	-40° to 180°F	-40° to 82°C	32° to 150°F	0° to 66°C
TPE (HY)	-20° to 150°F	-29° to 66°C	32° to 150°F	0° to 66°C

* The maximum temperature listed is based on the ATEX standard for T4 temperature classification. If you are operating in a non-explosive environment, FKM fluoroelastomer's maximum fluid temperature in aluminum or stainless steel pumps is 320°F (160°C).

Customer Services/Guarantee

CUSTOMER SERVICES

If you require spare parts, please contact your local distributor, providing the following details:

- Pump Model
- Type
- Serial Number, and
- Date of First Order.

GUARANTEE

All VERDER pumps are warranted to the original user against defects in workmanship or materials under normal use (rental use excluded) for two years after purchase date. This warranty does not cover failure of parts or components due to normal wear, damage or failure which in the judgement of VERDER arises from misuse.

Parts determined by VERDER to be defective in material or workmanship will be repaired or replaced.

LIMITATION OF LIABILITY

To the extent allowable under applicable law, VERDER's liability for consequential damages is expressly disclaimed. VERDER's liability in all events is limited and shall not exceed the purchase price.

WARRANTY DISCLAIMER

VERDER has made an effort to illustrate and describe the products in the enclosed brochure accurately; however, such illustrations and descriptions are for the sole purpose of identification and do not express or imply a warranty that the products are merchantable, or fit for a particular purpose, or that the products will necessarily conform to the illustration or descriptions.

PRODUCT SUITABILITY

Many regions, states and localities have codes and regulations governing the sale, construction, installation and/or use of products for certain purposes, which may vary from those in neighboring areas. While VERDER attempts to assure that its products comply with such codes, it cannot guarantee compliance, and cannot be responsible for how the product is installed or used. Before purchasing and using a product, please review the product application as well as the national and local codes and regulations, and be sure that product, installation, and use complies with them.

Original instructions. This manual contains English.

Revision G, December 2019

Austria

Verder Austria
 Eitnergasse 21/Top 8
 A-1230 Wien
 AUSTRIA
 Tel: +43 1 86 51 074 0
 Fax: +43 1 86 51 076
 e-mail: office@verder.at

Belgium

Verder nv
 Kontichsesteenweg 17
 B-2630 Aartselaar
 BELGIUM
 Tel: +32 3 877 11 12
 Fax: +32 3 877 05 75
 e-mail: info@verder.be

China

Verder Shanghai Instruments and Equipment Co., Ltd
 Building 8 Fuhai Business Park No. 299
 Bisheng Road, Zhangjiang Hiteck Park
 Shanghai 201204
 CHINA
 Tel: +86 21 33932950
 Fax: +86 21 33932955
 e-mail: info@verder.cn

Bulgaria

Verder Bulgaria Ltd
 Vitosh department,
 Manastriski Livadi Zapad
 district,
 110 Bulgaria Blvd., 2-nd
 Floor, apt. 15-16,
 1618 - Sofia
 BULGARIA
 Tel: 0878407370
 Fax: 02 9584085
 email: office@verder.bg

Czech Republic

Verder s.r.o.
 Vodnanská 651/6 (vchod
 Chlumecka 15)
 198 00 Praha 9-Kyje
 CZECH REPUBLIC
 Tel: +420 261 225 386-7
 Web: <http://www.verder.cz>
 e-mail: info@verder.cz

France

Verder France
 8 Allée Rosa Luxembourg
 Immeulde Arizona
 95610 Eragny sur Oise
 FRANCE
 Tel: +33 173 43 98 41
 Fax: +33 134 64 44 50
 e-mail: info@verder.fr

Germany

Verder Deutschland GmbH
 Retsch-Allee 1-5
 42781 Haan
 GERMANY
 Tel: 02104/2333-200
 Fax: 02104/2333-299
 e-mail: info@verder.de

Hungary

Verder Hungary Kft
 Budafoke ut 187 - 189
 HU-1117 Budapest
 HUNGARY
 Tel: 0036 1 3651140
 Fax: 0036 1 3725232
 e-mail: info@verder.hu

India

Verder India Pumps Pvt
 Ltd.
 Plot No-3B, D-1 Block,
 MIDC Chinchwad,
 Pune - 411019
 INDIA
 e-mail:
 Sales@verder.co.in
 www.verder.co.in

Italy

Verder Italia
 Via Maestri Del lavoro, 5
 02100 Vazia, Rieti
 ITALY
 Tel: +39 07 46 229064
 e-mail: info@verder.it

The Netherlands

Verder BV
 Leningradweg 5
 NL 9723 TP Groningen
 THE NETHERLANDS
 Tel: +31 50 549 59 00
 Fax: +31 50 549 59 01
 e-mail: info@verder.nl

Poland

Verder Polska
 ul.Porcelanowa 23
 PL-40 036 Katowice
 POLAND
 Tel: +48 32 78 15 032
 Fax: +48 32 78 15 034
 e-mail: verder@verder.pl

Romania

Verder România
 Drumul Balta Doamnei
 no 57-61
 Sector 3
 CP 72-117
 032624 Bucuresti
 ROMANIA
 Tel: +40 21 335 45 92
 Fax: +40 21 337 33 92
 e-mail: office@verder.ro

Slovak Republik

Verder Slovakia s.r.o.
 Silacska 1
 SK-831 02 Bratislava
 SLOVAK REPUBLIK
 Tel: +421 2 4463 07 88
 Fax: +421 2 4445 65 78
 e-mail: info@verder.sk

South Africa

Verder SA
 197 Flaming Rock Avenue
 Northlands Business Park
 Newmarket Street
 ZA Northriding
 SOUTH AFRICA
 Tel: +27 11 704 7500
 Fax: +27 11 704 7515
 e-mail: info@verder.co.za

Switzerland

Verder Deutschland GmbH
 Sales Switzerland
 Retsch-Allee 1-5
 D-42781 Haan
 GERMANY
 Tel: +41 (0)61 331 33 13
 Fax: +41 (0)61 331 63 22
 e-mail: info@verder.ch

United Kingdom

Verder UK Ltd.
 Unit 3 California Drive
 Castleford, WF10 5QH
 UNITED KINGDOM
 Tel: +44 (0) 1924 221 001
 Fax: +44 (0) 1132 465 649
 e-mail: info@verder.co.uk

United States of America

Verder Inc.
 312 Corporate Parkway
 Suite 101
 Macon, GA 31210
 USA
 Tel: +1 877 783 7337
 Fax: +1 478 476 9867
 e-mail: sales@verder-us.com