

Repair/Parts



VERDERAIR VA-E50

Electric-Operated Diaphragm

Pump

859.0765
Rev.D
EN

2-Inch pumps with electric drive for fluid transfer applications.
Not approved for use in explosive atmospheres or hazardous locations unless otherwise stated. See Approvals page for more information. For professional use only.



Important Safety Instructions

Read all warnings and instructions in this manual and in your Operation manual. **Save these instructions.**

Maximum Working Pressure: 7 bar (0.7 MPa, 100 psi).

See page 8 for approvals.

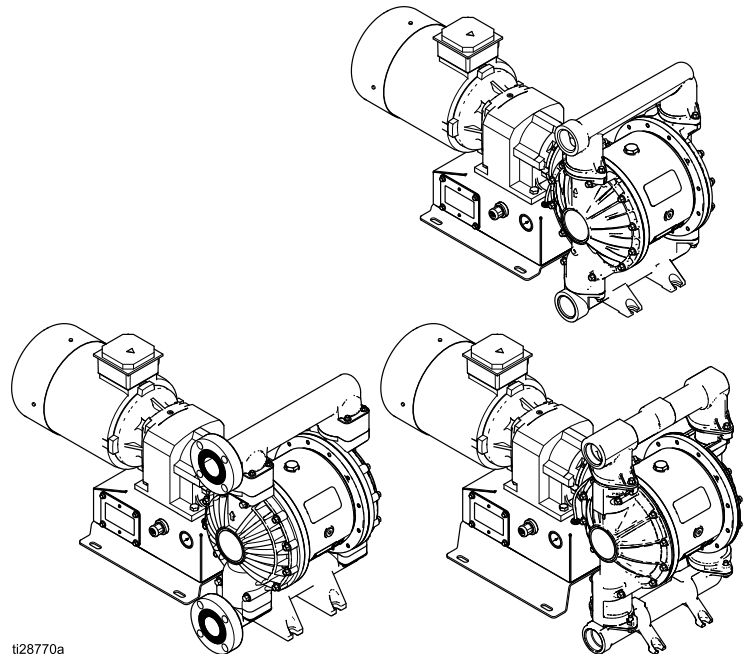

Contents



Related Manuals	2	Leak Sensor Repair	19
Warnings	3	Replace the Compressor	20
Pump Matrix.....	6	Torque Instructions	21
Troubleshooting.....	9	Torque sequence	21
Repair.....	11	Parts.....	23
Pressure Relief Procedure.....	11	Kits and Accessories	33
Check Valve Repair	11	Technical Data	34
Diaphragm Repair.....	13	Customer Services/Guarantee.....	39
Center Section Repair	15		





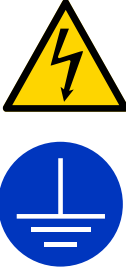

Related Manuals







Manual Number	Title
859.0761	VA-E50 Electric-Operated Diaphragm Pump, Operation

Warnings

The following warnings are for the setup, use, grounding, maintenance, and repair of this equipment. The exclamation point symbol alerts you to a general warning and the hazard symbols refer to procedure-specific risks. When these symbols appear in the body of this manual or on warning labels, refer back to these Warnings. Product-specific hazard symbols and warnings not covered in this section may appear throughout the body of this manual where applicable.

 <h2 style="margin: 0;">WARNING</h2>	
	<p>ELECTRIC SHOCK HAZARD</p> <p>This equipment must be grounded. Improper grounding, setup, or usage of the system can cause electric shock.</p> <ul style="list-style-type: none"> • Turn off and remove power before disconnecting any cables and before servicing or installing equipment. For cart-mounted models, unplug the power cord. For all other units, disconnect power at the main switch. • Connect only to grounded power source. • All electrical wiring must be done by a qualified electrician and comply with all local codes and regulations. • Wait five minutes for capacitor discharge before opening equipment.
	<p>FIRE AND EXPLOSION HAZARD</p> <p>Flammable fumes, such as solvent and paint fumes, in work area can ignite or explode. Paint or solvent flowing through the equipment can cause static sparking. To help prevent fire and explosion:</p> <ul style="list-style-type: none"> • Use equipment only in well ventilated area. • Eliminate all ignition sources; such as pilot lights, cigarettes, portable electric lamps, and plastic drop cloths (potential static arc). • Ground all equipment in the work area. See Grounding instructions. • Keep work area free of debris, including solvent, rags and gasoline. • Do not plug or unplug power cords, or turn power or light switches on or off when flammable fumes are present. • Use only grounded hoses. • Stop operation immediately if static sparking occurs or you feel a shock. Do not use equipment until you identify and correct the problem. • Keep a working fire extinguisher in the work area. <p>Static charge may build up on plastic parts during cleaning and could discharge and ignite flammable vapors. To help prevent fire and explosion:</p> <ul style="list-style-type: none"> • Clean plastic parts only in well ventilated area. • Do not clean with a dry cloth. • Do not operate electrostatic guns in equipment work area.

 <h1 style="margin: 0;">WARNING</h1>	
  	<p>PRESSURIZED EQUIPMENT HAZARD</p> <p>Fluid from the equipment, leaks, or ruptured components can splash in the eyes or on skin and cause serious injury.</p> <ul style="list-style-type: none"> • Follow the Pressure Relief Procedure when you stop spraying/dispensing and before cleaning, checking, or servicing equipment. • Tighten all fluid connections before operating the equipment. • Check hoses, tubes, and couplings daily. Replace worn or damaged parts immediately.
 	<p>EQUIPMENT MISUSE HAZARD</p> <p>Misuse can cause death or serious injury.</p> <ul style="list-style-type: none"> • Do not operate the unit when fatigued or under the influence of drugs or alcohol. • Do not exceed the maximum working pressure or temperature rating of the lowest rated system component. See Technical Data in all equipment manuals. • Use fluids and solvents that are compatible with equipment wetted parts. See Technical Data in all equipment manuals. Read fluid and solvent manufacturer's warnings. For complete information about your material, request Safety Data Sheet (SDS) from distributor or retailer. • Turn off all equipment and follow the Pressure Relief Procedure when equipment is not in use. • Check equipment daily. Repair or replace worn or damaged parts immediately with genuine manufacturer's replacement parts only. • Do not alter or modify equipment. Alterations or modifications may void agency approvals and create safety hazards. • Make sure all equipment is rated and approved for the environment in which you are using it. • Use equipment only for its intended purpose. Call your distributor for information. • Route hoses and cables away from traffic areas, sharp edges, moving parts, and hot surfaces. • Do not kink or over bend hoses or use hoses to pull equipment. • Keep children and animals away from work area. • Comply with all applicable safety regulations.
	<p>PRESSURIZED ALUMINUM PARTS HAZARD</p> <p>Use of fluids that are incompatible with aluminum in pressurized equipment can cause serious chemical reaction and equipment rupture. Failure to follow this warning can result in death, serious injury, or property damage.</p> <ul style="list-style-type: none"> • Do not use 1,1,1-trichloroethane, methylene chloride, other halogenated hydrocarbon solvents or fluids containing such solvents. • Do not use chlorine bleach. • Many other fluids may contain chemicals that can react with aluminum. Contact your material supplier for compatibility.

 <h1 style="margin: 0;">WARNING</h1>	
	<p>THERMAL EXPANSION HAZARD</p> <p>Fluids subjected to heat in confined spaces, including hoses, can create a rapid rise in pressure due to the thermal expansion. Over-pressurization can result in equipment rupture and serious injury.</p> <ul style="list-style-type: none"> • Open a valve to relieve the fluid expansion during heating. • Replace hoses proactively at regular intervals based on your operating conditions.
	<p>PLASTIC PARTS CLEANING SOLVENT HAZARD</p> <p>Many solvents can degrade plastic parts and cause them to fail, which could cause serious injury or property damage.</p> <ul style="list-style-type: none"> • Use only compatible water-based solvents to clean plastic structural or pressure-containing parts. • See Technical Data in this and all other equipment instruction manuals. Read fluid and solvent manufacturer's Safety Data Sheet (SDS) and recommendations.
	<p>TOXIC FLUID OR FUMES HAZARD</p> <p>Toxic fluids or fumes can cause serious injury or death if splashed in the eyes or on skin, inhaled, or swallowed.</p> <ul style="list-style-type: none"> • Read Safety Data Sheet (SDS) to know the specific hazards of the fluids you are using. • Store hazardous fluid in approved containers, and dispose of it according to applicable guidelines.
	<p>BURN HAZARD</p> <p>Equipment surfaces and fluid that's heated can become very hot during operation. To avoid severe burns:</p> <ul style="list-style-type: none"> • Do not touch hot fluid or equipment.
	<p>PERSONAL PROTECTIVE EQUIPMENT</p> <p>Wear appropriate protective equipment when in the work area to help prevent serious injury, including eye injury, hearing loss, inhalation of toxic fumes, and burns. This protective equipment includes but is not limited to:</p> <ul style="list-style-type: none"> • Protective eyewear, and hearing protection. • Respirators, protective clothing, and gloves as recommended by the fluid and solvent manufacturer.

Pump Matrix

Check the identification plate (ID) for the Configuration Number of your pump. Use the following matrix to define the components of your pump.

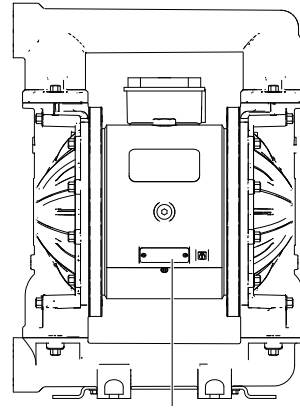

t31441a

Sample Configuration Number: VA-E50 AA HY AC HY TB AC5K5





VA-E50	A	A	HY	AC	HY	TB	AC5K5
Pump Model	Fluid Section Material	Drive Section Material	Check Valve Seats	Check Valve Balls	Diaphragm	Connections	Options

NOTE: Some combinations are not possible. Please check with your local supplier or the pump configurator on www.verderair.com.

Pump	Fluid Section Material		Drive Section Material		Check Valve Seats	
VA-E50	A	Aluminum	A	Aluminum	GE	Geolast
	C	Conductive Polypropylene	S	Stainless Steel	HY	TPE
	I	Cast Iron			KY	PVDF
	K	PVDF			PP	Polypropylene
	P	Polypropylene			SP	Santoprene
	S	Stainless Steel			SS	Stainless Steel

Balls		Diaphragm		Connections		Options	
AC	Acetal	GE	Geolast	FC-H	Center Flange, Horizontal Outlet	A15K5	Standard AC Induction Motor (High Speed Gear Ratio) with 120V Air Compressor
GE	Geolast	HY	TPE	FC-V	Center Flange, Vertical Outlet	A25K5	Standard AC Induction Motor (High Speed Gear Ratio) with 220V Air Compressor
HD	440C Stainless Steel	SP	Santoprene	FE	End Flange DIN/ANSI	AC5K5	Standard AC Induction Motor (High Speed Gear Ratio)
HY	TPE	TF	PTFE / Polychloroprene 2-Piece	TB	Threaded BSP	AF5K5	Flameproof AC Induction Motor (High Speed Gear Ratio)
NW	Polychloroprene Weighted			TN	Threaded NPT	AX5K5	ATEX AC Induction Motor (High Speed Gear Ratio)
SP	Santoprene			B14K0	Standard AC Induction Motor (Medium Speed Gear Ratio) with 120V Compressor		
SS	316 Stainless Steel			B24K0	Standard AC Induction Motor (Medium Speed Gear Ratio) with 220V Compressor		
TF	PTFE			BC4K0	Standard AC Induction Motor (Medium Speed Gear Ratio)		
				BF4K0	Flameproof AC Induction Motor (Medium Speed Gear Ratio)		
				BX4K0	ATEX AC Induction Motor (Medium Speed Gear Ratio)		
				C12K2	Standard AC Induction Motor (Low Speed Gear Ratio) with 120V Compressor		
		C22K2	Standard AC Induction Motor (Low Speed Gear Ratio) with 220V Compressor				
		CC2K2	Standard AC Induction Motor (Low Speed Gear Ratio)				
		CF2K2	Flameproof AC Induction Motor (Low Speed Gear Ratio)				
		CX2K2	ATEX AC Induction Motor (Low Speed Gear Ratio)				
		WG	No Motor, No Gearbox				

Pump Matrix

Approvals	
<p>◆ Aluminum, cast iron, conductive polypropylene, and stainless steel pumps with motor code X are certified to:</p>	 II 2 G Ex h d IIB T3 Gb
<p>⊕ Aluminum, cast iron, conductive polypropylene, and stainless steel pumps with motor code WG are certified to:</p>	 II 2 G Ex h IIB T3 Gb
<p>★ Motors coded F are certified to:</p>	 Class I, Div 1, Group D, T3B Class II, Div 1, Group F & G, T3B 
<p>All Models (except gearbox and compressor code 1, or motor code F) are certified to:</p>	

Troubleshooting



- Follow the [Pressure Relief Procedure, page 11](#), before checking or servicing the equipment.
- Check all possible problems and causes before disassembly.

Problem	Cause	Solution
Pump cycles but will not prime and/or pump.	Pump is running too fast, causing cavitation before prime.	Slow down the controller (VFD)
	Center section has no air pressure, or air pressure is too low.	Apply air pressure to center section per your application requirements.
	Check valve ball is severely worn or wedged in seat or manifold.	Replace the ball and seat.
	The pump has insufficient suction pressure.	Increase the suction pressure. See the Operation manual.
	Seat is severely worn.	Replace the ball and seat.
	Outlet or inlet is restricted.	Remove the restriction.
	Inlet fittings or manifolds are loose.	Tighten.
	Manifold o-rings are damaged.	Replace o-rings.
The center section is excessively hot.	The drive shaft is broken.	Replace.
Pump fails to hold fluid pressure at stall.	Check valve balls, seats, or o-rings are worn.	Replace.
	Manifold screws or fluid cover screws are loose.	Tighten.
	Diaphragm shaft bolt is loose	Tighten.
Pump will not cycle.	Motor or controller is wired improperly.	Wire per manual.
	The leak detector (if installed) has tripped.	Check diaphragm for rupture or incorrect installation. Repair or replace.
The motor is operating, but the pump will not cycle.	The jaw coupling between the motor and gearbox is not connected properly.	Check the connection.
Pump flow rate is erratic.	Suction line is clogged.	Inspect; clear.
	Check balls are sticky or leaking .	Clean or replace.
	Diaphragm (or backup) ruptured.	Replace.
Pump makes unusual noises.	Pump is operating near or at stall pressure.	Adjust air pressure or slow the pump speed.

Troubleshooting

Problem	Cause	Solution
Air consumption is higher than expected.	A fitting is loose.	Tighten. Inspect thread sealant.
	Loose or damaged o-rings or shaft seal.	Replace.
	Diaphragm (or backup) ruptured.	Replace.
Air bubbles in fluid.	Suction line is loose.	Tighten.
	Diaphragm (or backup) ruptured.	Replace.
	Loose manifolds, damaged seats or o-rings.	Tighten manifold bolts or replace seats or o-rings.
	Loose diaphragm shaft bolt.	Tighten.
Pump leaks fluid externally from joints.	Loose manifold screws or fluid cover screws.	Tighten.
	Manifold o-rings worn out.	Replace o-rings.
The controller faults or shuts down.	A GFCI has tripped.	Remove the controller from the GFCI circuit.
	Supply power is poor.	Determine and fix the source of the power problem.
	Operational parameters are exceeded.	See performance chart; ensure pump is operating within the continuous duty range.
Excessive motor regeneration fault from VFD	Inlet check clogged/improperly installed	Remove debris/install properly
	Broken diaphragm bolt	Replace bolt
NOTE: For problems with a Variable Frequency Device (VFD), see your VFD manual.		

Repair

Pressure Relief Procedure



Follow the Pressure Relief Procedure whenever you see this symbol.

<p>This equipment stays pressurized until pressure is relieved manually. To help prevent serious injury from pressurized fluid, such as splashing in the eyes or on skin, follow the Pressure Relief Procedure when you stop pumping and before you clean, check, or service the equipment.</p>				

1. Remove power from the system.
2. Open the dispensing valve, if used.
3. Open the fluid drain valve to relieve fluid pressure. Have a container ready to catch the drainage.
4. Back out regulator knob to bleed any internal air pressure.

Check Valve Repair

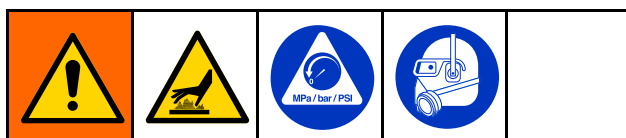

Tools Required

- Torque wrench
- 10 mm socket wrench (plastic pumps)
- 13 mm socket wrench (metal pumps)
- O-ring pick

NOTE: Kits are available for new check valve balls and seats in a range of materials. O-ring and fastener kits also are available.

NOTE: To ensure proper seating of the check balls, always replace the seats when replacing the balls. Also, replace the o-rings every time the manifold is removed.

Disassemble the Check Valve

1. Follow the [Pressure Relief Procedure, page 11](#). Remove power from the motor. Disconnect all hoses.
2. **NOTE for plastic pumps:** Use hand tools until thread-locking adhesive patch releases.
3. Use a 10 mm (plastic pump) or 13 mm (metal pump) socket wrench to remove the manifold fasteners (5) and nuts (42; used only on stainless steel models), then remove the outlet manifold (3).
4. Remove the seats (6), balls (7), and o-rings (8) if present.
NOTE: Some models do not use o-rings (8).
5. Repeat for the inlet manifold (4), o-rings (8) if present, seats (6), and balls (7).

To continue disassembly, see [Disassemble the Diaphragms, page 13](#).

Reassemble the Check Valve

1. Clean all parts and inspect for wear or damage. Replace parts as needed.
2. Reassemble in the reverse order, following all notes in the illustration. Put the inlet manifold on first. Be sure the ball checks and manifolds are assembled **exactly** as shown. The arrows (A) on the fluid covers (2) **must** point toward the outlet manifold (3).

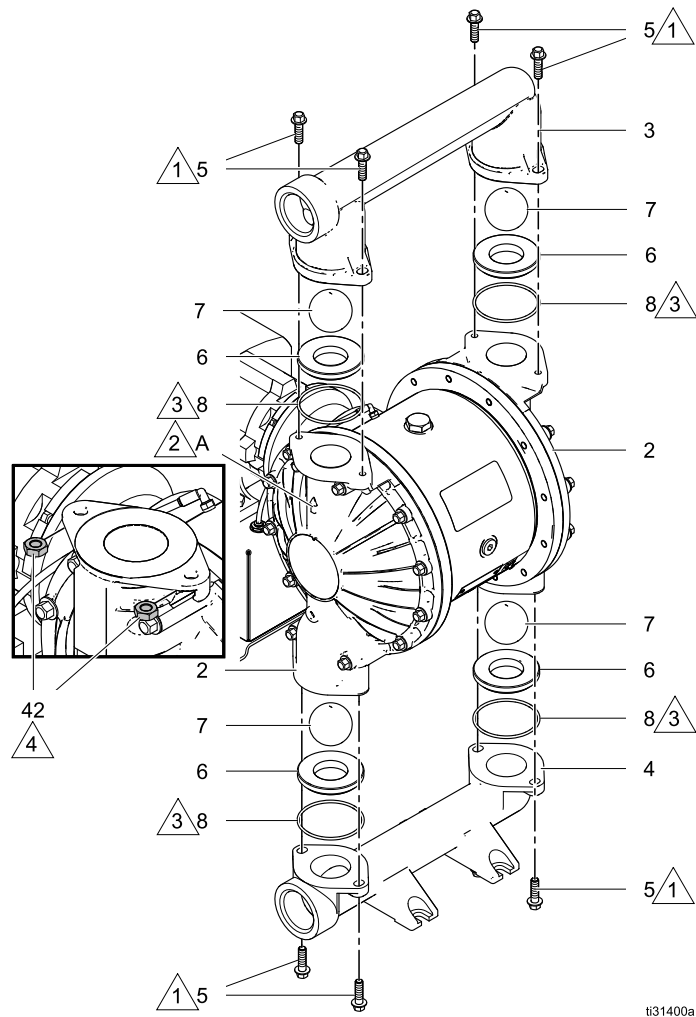

ti31400a

Check valve assembly, aluminum model shown



Apply medium-strength (blue) thread locker. Torque to the value specified for your pump. See [Torque Instructions, page 21](#).



Arrow (A) must point toward outlet manifold



Not used on some models.



Stainless steel models include nuts (42).

Diaphragm Repair

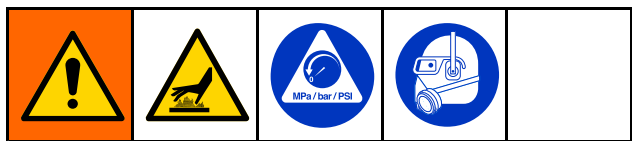

Disassemble the Diaphragms

NOTE: Diaphragm kits are available in a range of materials and styles. See Parts section.

1. Follow the [Pressure Relief Procedure, page 11](#). Remove power from the motor. Disconnect all hoses.
2. Remove the manifolds and disassemble the ball check valves as explained in [Check Valve Repair, page 11](#).
3. Use a 13 mm socket wrench to remove the bolts (5) from the fluid covers, then pull the fluid covers off of the pump.
4. To remove the diaphragms, the piston must be moved fully to one side. If the pump is not attached to the gearbox, turn the shaft by hand to move the piston. If the pump is still attached to the gearbox, loosen the screws and remove the fan cover. Turn the fan by hand to rotate the shaft to shift the piston to one side.

TIP: The air cover has 2 holes (H), one at the 9 o'clock position and another at the 3 o'clock position (shown below). Use pin (131), placed in either hole (H) as a brace for the wrench while removing or installing diaphragm bolts.

5. All Diaphragms

- a. **Metal Pumps:** Hold a 28 mm wrench on the wrench flats of the exposed piston shaft. Use another wrench (10 mm hex key) on the shaft bolt (13) to remove it. Then remove all parts of the diaphragm assembly.
Plastic Pumps: Hold a 28 mm wrench on the wrench flats of the exposed piston shaft. Use a 24 mm socket or box end wrench on the hex of the fluid side diaphragm plate to remove the cover. Then use a 10 mm hex key to remove the bolt.
- b. Rotate the drive shaft to move the piston fully to one side. See instructions in step 4. Repeat step 6a.

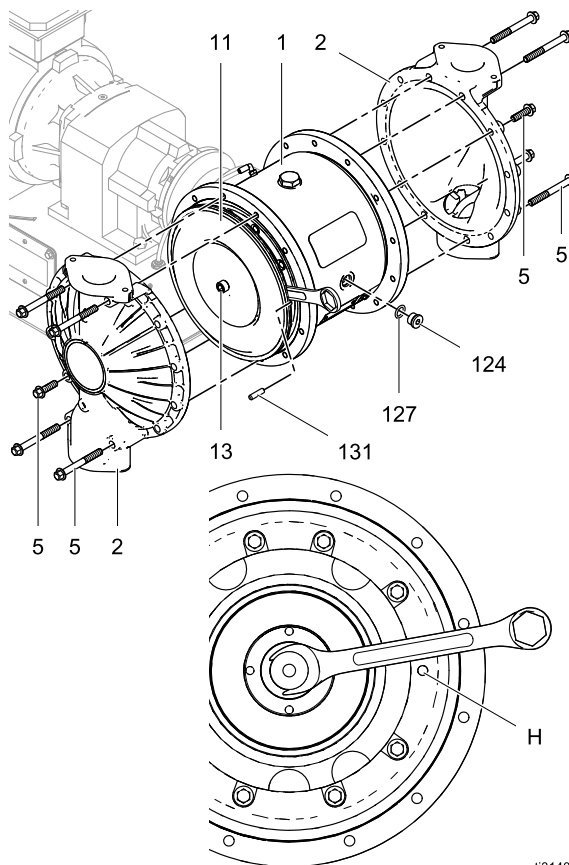

t31401a

6. To continue with disassembly, see [Disassemble the Center Section, page 15](#).

Reassemble the Diaphragms

Follow all notes in the illustrations on page 15. These notes contain **important** information.

NOTICE

After reassembly, allow the thread locker to cure for 12 hours, or per manufacturer's instructions, prior to operating the pump. Damage to the pump will occur if the diaphragm shaft bolt loosens.

TIP: If you are also repairing or servicing the center section (drive shaft, piston, etc.), see [Center Section Repair, page 15](#), before you put the diaphragms back on.

1. Clean all parts and inspect for wear or damage. Replace parts as needed. Be sure the center section is clean and dry.
2. **All Diaphragms-Metal Pumps**
 - a. Thoroughly clean or replace the diaphragm bolt (13). Install the o-ring (34).
 - b. Assemble the fluid side plate (9), the diaphragm (11), the backup diaphragm (12, if present), and the air side diaphragm plate (10) on the bolt exactly as shown.
 - c. Clean the female threads of the piston shaft with a wire brush dipped in solvent to remove any residual thread locker. Apply thread-locking primer and allow it to dry.
 - d. Apply medium-strength (blue) thread locker to the threads of the bolt.
 - e. Hold a 28 mm wrench on the wrench flats of the piston shaft. Screw the bolt onto the shaft and torque to 135 N•m (100 ft-lb).
 - f. Rotate the drive shaft to move the piston fully to one side. See instructions in step 4 of [Disassemble the Diaphragms, page 13](#).
 - g. Repeat to install the other diaphragm assembly.

1. Rounded side faces diaphragm.
2. Apply medium-strength (blue) thread locker to the threads.
3. AIR SIDE markings on diaphragm must face the center housing.
4. If the screw comes loose or is replaced, apply permanent (red) thread locker to diaphragm side threads. Apply medium-strength (blue) thread locker to shaft side threads.
5. Torque to 135 N•m (100 ft-lb) at 100 rpm maximum.
6. Apply primer to the female threads. Allow to dry.

3. All Diaphragms-Plastic Pumps

- a. Thoroughly clean or replace the diaphragm bolt (13). Install the o-ring (34).
 - b. Assemble the fluid side plate (9), the diaphragm (11), the backup diaphragm (12, if present), and the air side diaphragm plate (10) on the bolt exactly as shown.
 - c. Clean the female threads of the piston shaft with a wire brush dipped in solvent to remove any residual thread locker. Apply thread-locking primer and allow it to dry.
 - d. Apply medium-strength (blue) thread locker to the threads of the bolt.
 - e. Hold a 28 mm wrench on the wrench flats of the piston shaft. Screw the bolt onto the shaft and torque to 135 N•m (100 ft-lb).
 - f. Install an o-ring (13b) and plug (13a) on the fluid plate.
 - g. Rotate the drive shaft to move the piston fully to one side. See instructions in step 4 of [Disassemble the Diaphragms, page 13](#).
 - h. Repeat to install the other diaphragm assembly.
4. Attach the fluid covers. The arrow on each fluid cover must point toward the outlet manifold. Apply medium-strength (blue) thread locker to the bolt threads. See [Torque Instructions, page 21](#), to tighten.
 5. Reassemble the check valves and manifolds. See [Reassemble the Check Valve, page 11](#).
 6. Restore motor cooling fan cover and pin (131) to their original locations.

2-Piece (TF, HY, SP, and GE) Models

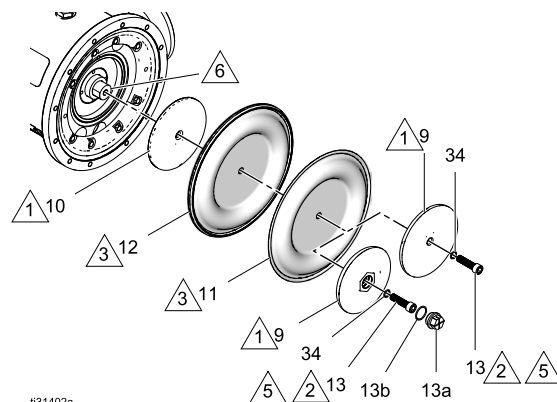

Center Section Repair

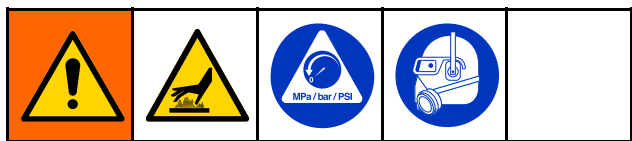

Disassemble the Center Section

See the illustrations on page 18.

1. Follow the [Pressure Relief Procedure, page 11](#). Remove power from the motor. Disconnect all hoses.
2. Remove the manifolds and check valve parts as directed in [Disassemble the Check Valve, page 11](#).
3. Remove the fluid covers and diaphragms as directed in [Disassemble the Diaphragms, page 13](#).
TIP: Clamp the gear box bracket (15) to the bench. Leave the pump connected to the motor.
4. Use a 10 mm hex wrench to remove 4 bolts (117). Pull the pump off the alignment housing (116).
TIP: It may be necessary to tap the pump with a rubber mallet to disengage the coupler.
5. Use a 5/16 hex wrench to remove the plug (124). Use a 30 mm socket wrench to remove the bearing bolt (106) and the o-ring (108) from the top.
6. Turn the shaft so the groove on the shaft is at the top, in line with the alignment markings.

7. Use a 3/4–16 bolt to push out the drive shaft assembly (112). You can also use the bearing bolt (106), but remove the bearing (107) first. Be sure that the groove on the drive shaft remains aligned with the markings in the center section.

NOTE: Remove the bolt after the drive shaft is freed.

NOTICE

Proper alignment is essential. Do not apply more than about 1.1 N•m (10 in-lb) of torque. Excessive torque could strip the housing thread. If you encounter resistance, check alignment or contact your distributor.

8. The shaft coupler (113) might come out with the drive shaft assembly. If not, remove from gearbox (118).
9. Remove the seal cartridge (110), the o-ring (109) and the radial seal (111) from the drive shaft assembly.
10. Slide the piston assembly (102) out of the center.
11. Only remove the alignment housing (116) if needed. Use a 10 mm hex wrench to remove 4 bolts (120). Pull the alignment housing off the gearbox (118).
12. Leave the gearbox coupler (114) attached to the gearbox shaft (118) unless it is damaged. If you need to remove it, a bearing puller must be used.

Reassemble the Center Section

1. Clean and dry the center housing (101), the center of the piston (102) and the drive shaft (112).
2. Inspect the piston and center section bearings for excessive wear and replace if needed. Grease the piston as shown and install it in the center section with the slot on the top, in line with the alignment markings in the center section.
3. Install the o-ring (108) and apply medium-strength (blue) thread locker to the bearing bolt (106) and screw into the center section. Be sure that the bearing (107) is in the slot on the piston, as shown. Be sure that the piston moves freely. Torque the bolt (106) to 20–34 N•m (15–25 ft-lb).

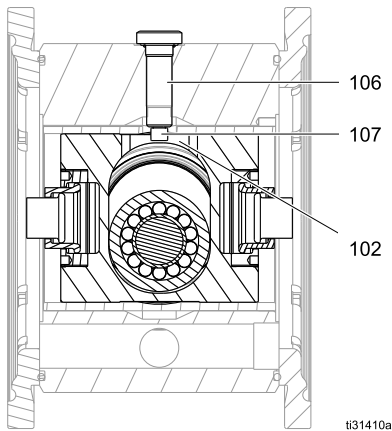

4. Be sure the sealing surface of the drive shaft (112) is clean. Install the seal cartridge (110) and the radial seal (111) on the drive shaft. The lips on the radial seal (111) must face **IN** toward the center. Inspect seal lip for damage. Replace if necessary.

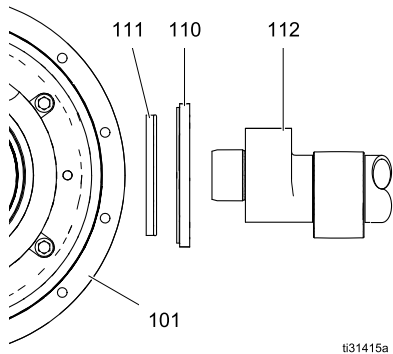

5. Install o-ring (109) to the center housing (101).
6. Apply anti-seize lubricant on the mating edges of the drive shaft, as shown in the illustration, page 18.
7. Center the piston in the housing and install the drive shaft assembly (112) into the center housing (101) with the groove facing up.
8. Inspect the shaft coupler (113) for wear and replace if needed. Install on the drive shaft.
9. If removed, install the alignment housing to the center section. Apply medium-strength (blue) thread locker and install the housing screws (117). Torque to 15–18 N•m (130–160 in-lb).
10. If removed, install the gearbox coupler (114) on the gearbox (118) shaft. Use an M12 x 30 bolt and a large washer inserted into the hole in the shaft to press the coupler into position. The coupler is in proper position when it is flush with the end of the shaft.
11. Be sure the gearbox coupler (114) is aligned properly. Turn by hand if needed. Connect the pump to the gearbox assembly, engaging the couplers.
12. Apply medium-strength (blue) thread locker and install the gearbox screws (120). Torque to 15–18 N•m (130–160 in-lb).
13. Be sure o-ring (127) is on the plug (124). Install the plug and torque to 20–34 N•m (15–25 ft-lb).
14. See [Reassemble the Diaphragms, page 14](#), and [Reassemble the Check Valve, page 11](#).

- 1 Apply medium-strength (blue) thread locker to threads.
- 2 Torque to 20–34 N•m (15–25 ft-lb).
- 3 Lips must face **IN** toward the center.
- 4 Apply anti-seize lubricant liberally on the radial surfaces of the drive shaft assembly.
- 5 Install the drive shaft assembly with the groove facing up.
- 6 Tighten screws in a crisscross pattern, 5 turns at a time, to engage the coupler evenly. Torque to 15–18 N•m (130–160 in-lb).
- 7 Apply lubricant to inner mating surface.

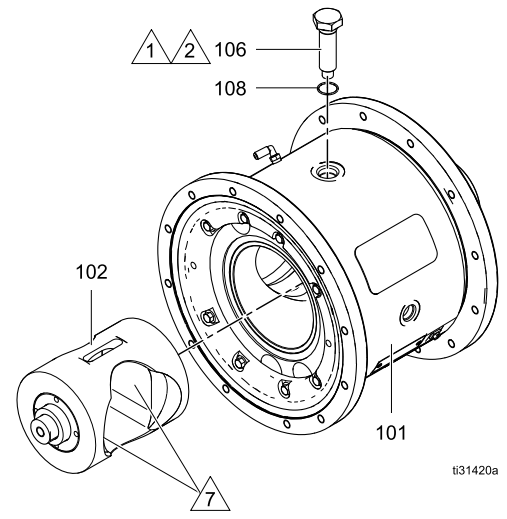

ti31420a

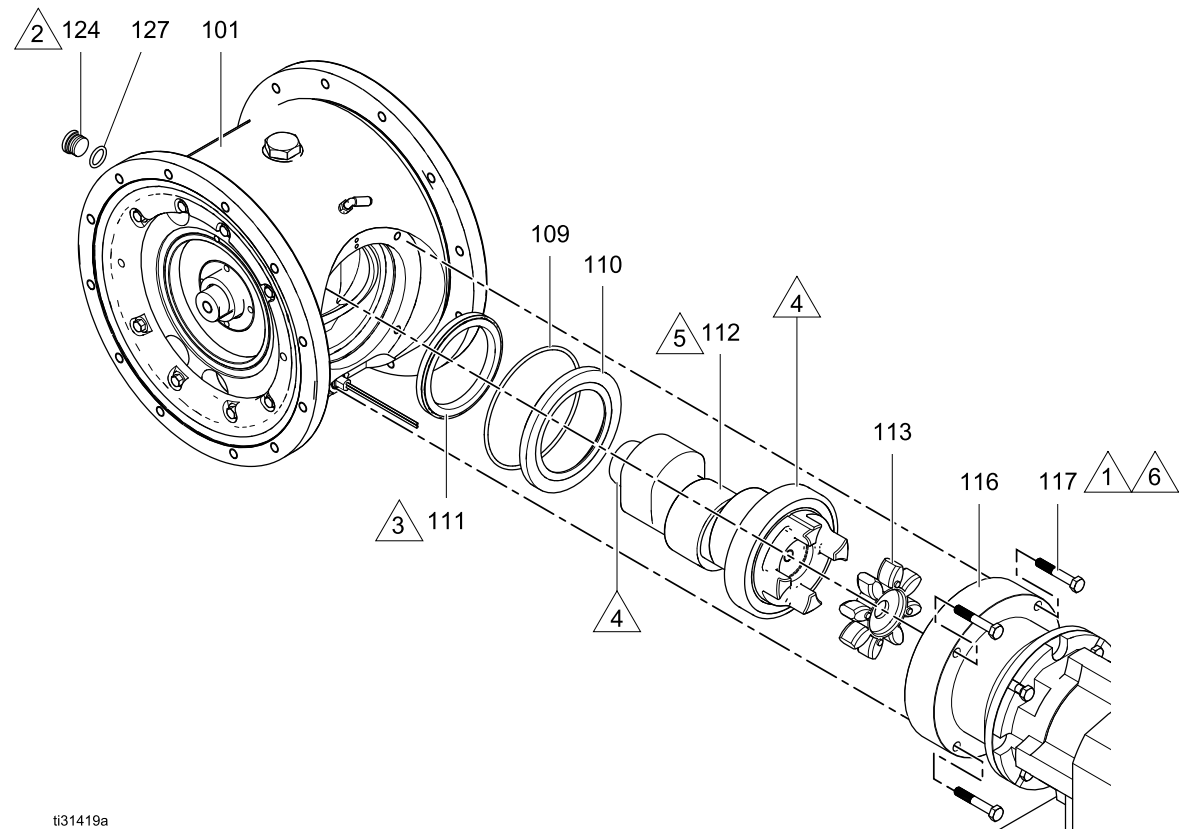

ti31419a

Leak Sensor Repair

The leak sensor can be replaced or re-positioned. When properly positioned, the two arrows imprinted on two of the flat surfaces of the leak sensor hex head are vertical and pointing down.

Leak Sensor Testing

Testing the continuity of the leak sensor is possible to ensure proper operation. If continuity testing indicates that the leak sensor is not functional, a replacement kit, 819.1273, can be ordered separately.

1. Follow the [Pressure Relief Procedure, page 11](#). Remove power from the motor.
2. To test the leak sensor without removing from the pump:
 - a. Note the connection locations of the leak sensor wires within the VFD or other monitoring device, then disconnect the leak sensor wires.
 - b. Use an ohmmeter attached to the leak sensor leads to test the conductivity of the leak sensor. Continuity is affirmed by a reading of 0-5 ohms.
 - c. Loosen the leak sensor bushing 1/2 turn (leak sensor arrows point up).
 - d. Use an ohmmeter attached to the leak sensor leads to test the conductivity of the leak sensor. An open circuit should be indicated.

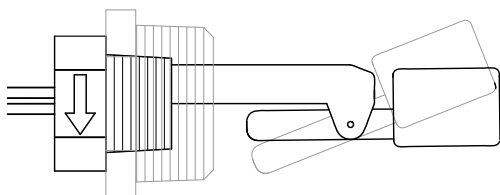



ti33058a

Normal operation position shown by dark float. Lighter float line indicates the open circuit position.

- e. If the continuity tests result indicate that the leak sensor is not functioning properly, proceed to step 3. Otherwise, tighten the bushing to its original position so that the arrows on the leak sensor point down. Attach the removed leak sensor wires to the point where they were disconnected from the VFD or other monitoring device.
- f. Apply air pressure to the pump and use a soapy solution around the bushing to ensure an air tight seal. If air bubbles appear, it will be necessary to return to the steps above for air pressure relief and removing the bushing from the pump. Apply new thread sealer on the bushing and install in the pump so that the leak sensor is properly positioned. Repeat this step to test for air leakage around the bushing.
3. Remove and replace the leak sensor at the pump:
 - a. Note the connection locations of the leak sensor wires within the VFD or other monitoring device, then disconnect the leak sensor wires.
 - b. Remove the leak sensor and bushing from the pump center section.
 - c. Apply thread tape or paste to the bushing threads and screw finger tight into the pump.
 - d. To ensure a watertight seal, apply Loctite® 425 Assure™ threadlocker supplied with the leak sensor kit to the leak sensor threads and screw the leak sensor into the bushing.
 - e. Verify that the leak sensor was properly oriented in the pump so that the arrows imprinted on the leak sensor hex head are vertical positioned with the arrows pointing down. It may be necessary to further tighten both the bushing and leak sensor to achieve proper positioning.
 - f. Use an ohmmeter attached to the leak sensor leads to test the conductivity of the leak sensor. Continuity is affirmed by a reading of 0-5 ohms. Attach the leak sensor wires to the VFD or other monitoring device.
 - g. Apply air pressure to the pump and use a soapy solution around the bushing to ensure an air tight seal. If air bubbles appear, it will be necessary to return to the steps above for air pressure relief and removing the bushing from the pump. Apply new thread sealer on the bushing and install in the pump so that the leak sensor is properly positioned. Repeat this step to test for air leakage around the bushing.

Replace the Compressor

				
<p>To avoid injury from fire, explosion, or electric shock, all electrical wiring must be done by a qualified electrician and comply with all local codes and regulations.</p>				

1. Follow the [Pressure Relief Procedure, page 11](#).
2. Remove electrical power from the pump.
3. Remove the 8 bolts holding the pump to the mounting surface.
4. Tip the pump on its side to provide access to the compressor box.
5. Remove riser bracket (35).
6. Remove the air line (A1) from the compressor. Disconnect the compressor wires at the terminal block (L1, L2, and ground). Remove the four bolts, and carefully pull the compressor out of the box.
7. Use the four bolts to install the new compressor. Connect the air line from A1 to A1, as shown.
8. Connect the wires from the new compressor to the terminal block, as shown.
9. Replace riser bracket.
10. Return the pump to its mounting location. Secure it with the 8 bolts.
11. Return power to the pump.

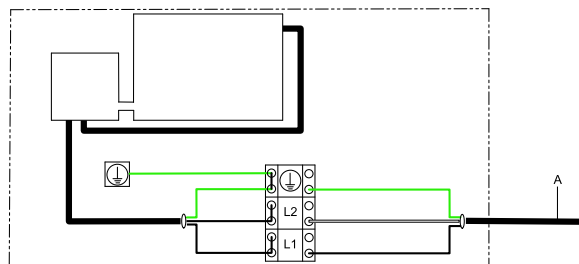
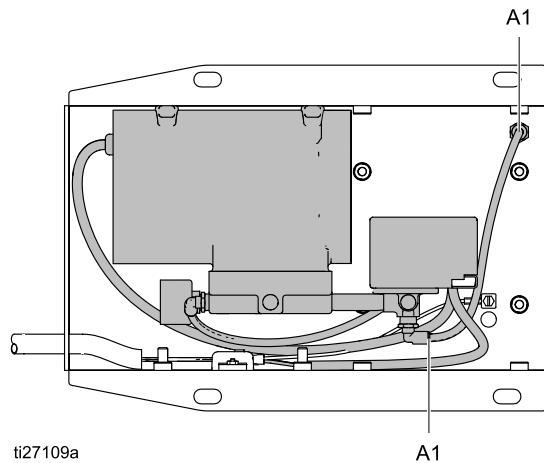
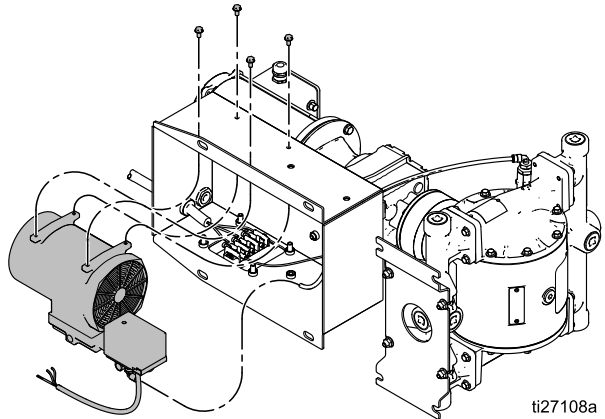

Torque Instructions

If fluid cover or manifold fasteners have been loosened, it is important to torque them using the following procedure to improve sealing.

NOTE: Fluid cover and manifold fasteners have a thread-locking adhesive patch applied to the threads. If this patch is excessively worn, the fasteners may loosen during operation. Replace screws with new ones or apply medium-strength (blue) thread locker to the threads.

NOTE: Always completely torque fluid covers before torquing manifolds.

1. Start all fluid cover screws a few turns. Then, turn down each screw just until head contacts cover.
2. Turn each screw by 1/2 turn or less working in a crisscross pattern to specified torque.
3. Repeat for manifolds.

Torque sequence

Aluminum Pumps

1. Left/Right Fluid Covers

Torque bolts to 22.6–23.7 N•m (200-210 in-lb)

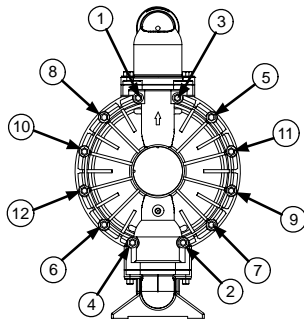

SIDE VIEW

2. Inlet Manifold

Torque bolts to 14.7–15.8 N•m (130-140 in-lb)

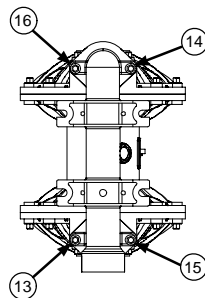

BOTTOM VIEW

3. Outlet Manifold

Torque bolts to 14.7–15.8 N•m (130-140 in-lb)

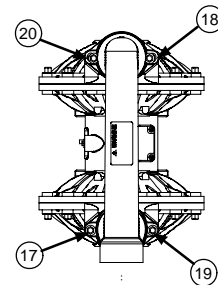

TOP VIEW

Stainless Steel and Ductile Iron Pumps

1. Left/Right Fluid Covers

Torque bolts to 22.6–23.7 N•m (200-210 in-lb)

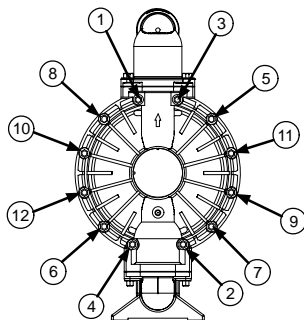

SIDE VIEW

2. Inlet Manifold

Torque bolts to 22.6–23.7 N•m (200-210 in-lb)

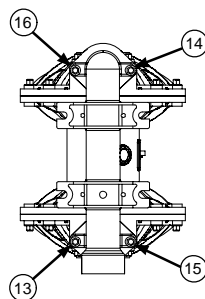

BOTTOM VIEW

3. Outlet Manifold

Torque bolts to 22.6–23.7 N•m (200-210 in-lb)

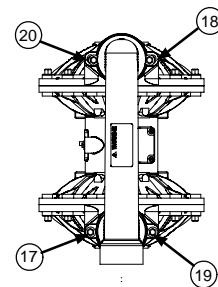

TOP VIEW

Plastic Pumps

1. Left/Right Fluid Covers

Torque bolts to 22.6–23.7 N•m
(200-210 in-lb)

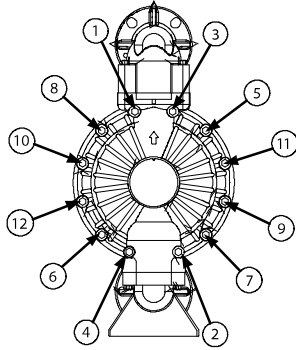

SIDE VIEW

2. Inlet Manifold

Torque bolts to 17–18 N•m
(150-160 in-lb)

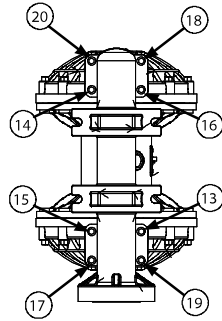

BOTTOM VIEW

3. Outlet Manifold

Torque bolts to 17–18 N•m
(150-160 in-lb)

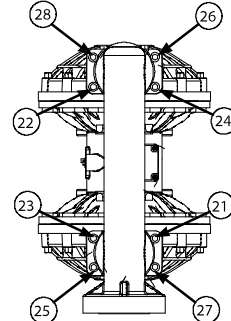

TOP VIEW

Parts

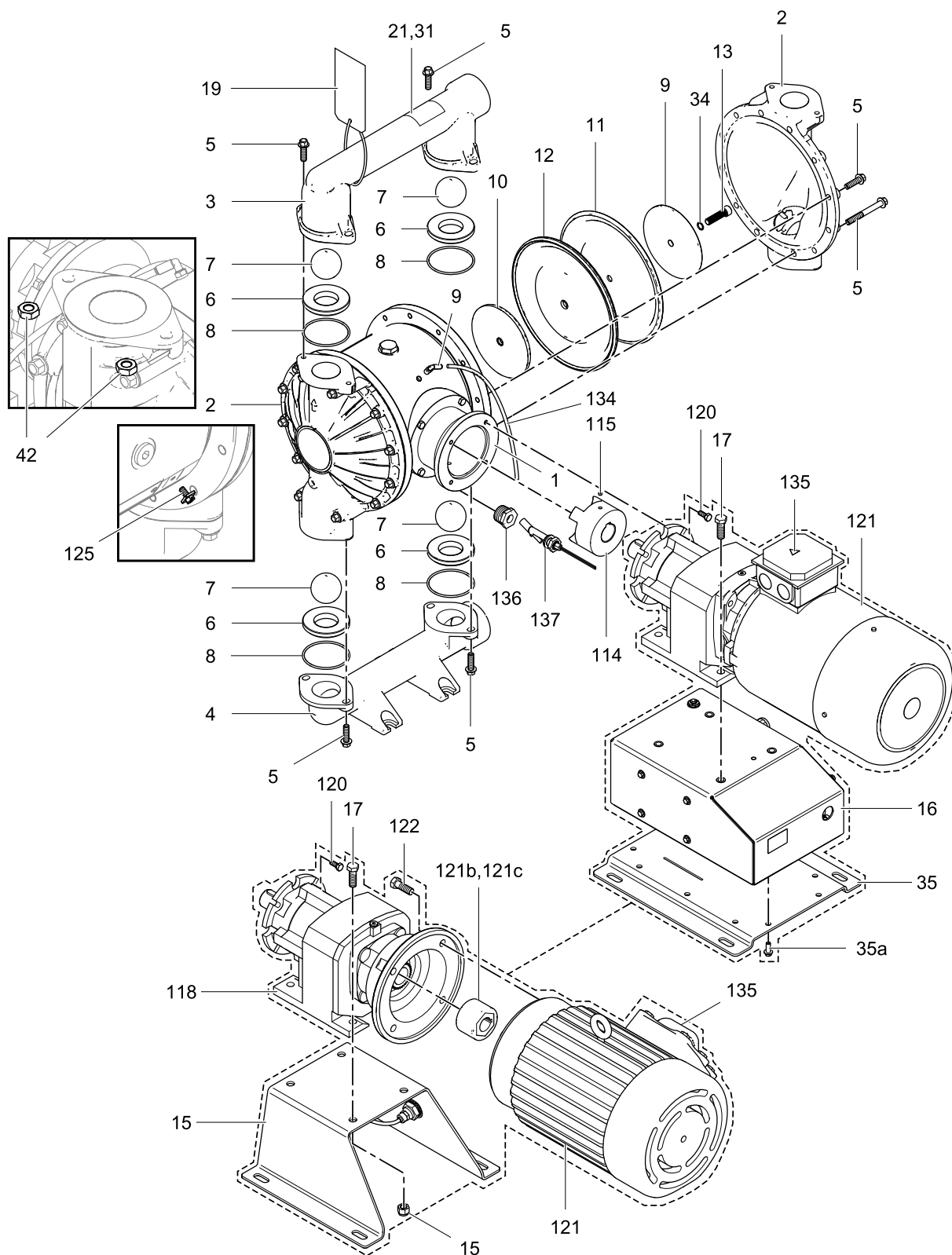

ti31426a

Parts

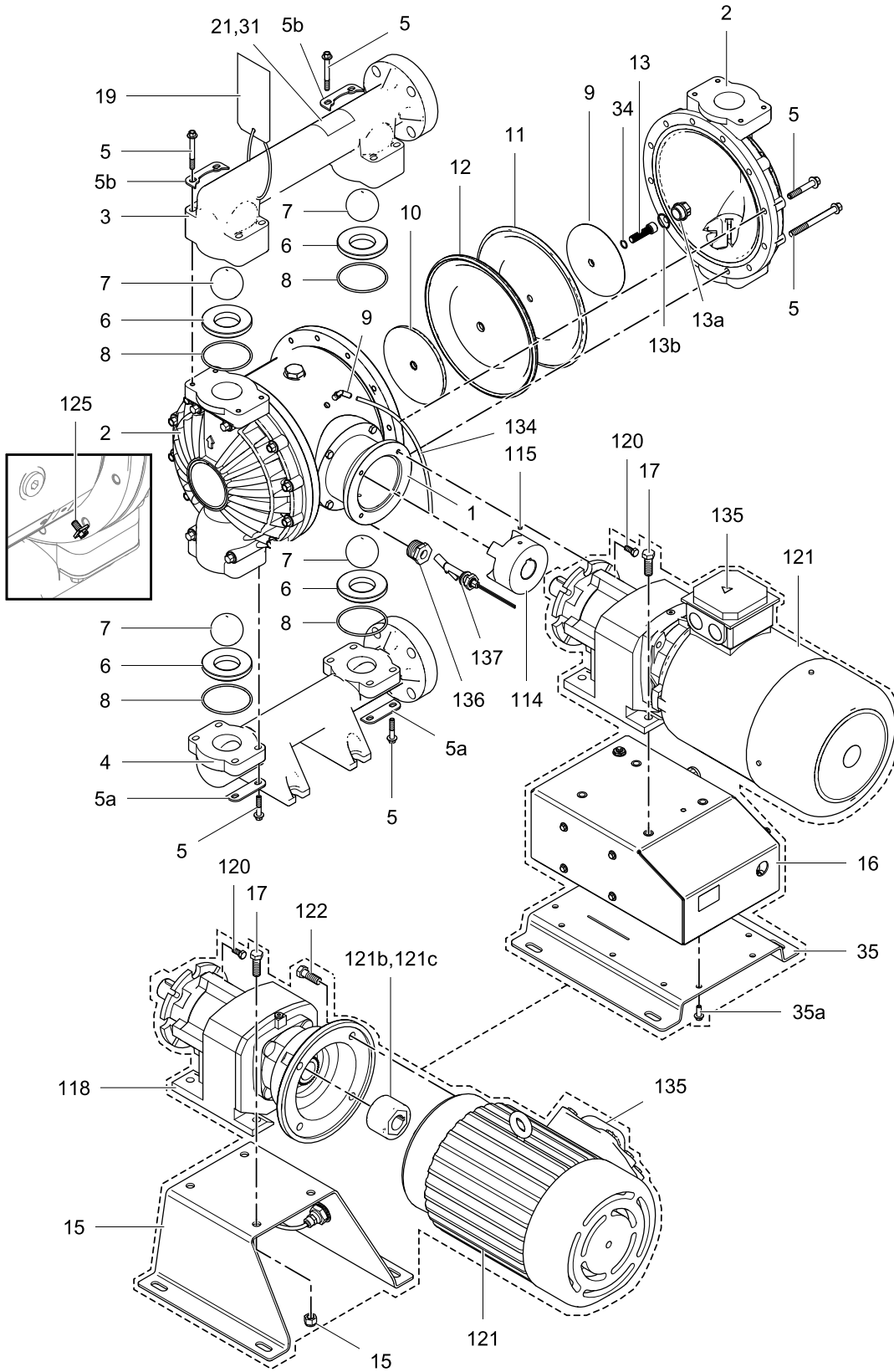

ti31477a

Parts/Kits Quick Reference

Use this table as a quick reference for parts/kits. Go to the pages indicated in the table for a full description of kit contents.

Ref.	Part/Kit	Description	Qty.
1	-----	MODULE, drive; <i>See pages 30-31.</i>	1
2	-----	COVER, fluid; <i>See page 32.</i>	2
3	-----	MANIFOLD, outlet; <i>See pages 32-33</i>	1
4	-----	MANIFOLD, inlet; <i>See pages 32-33</i>	1
5		FASTENERS:	
		Aluminum fluid section	
	819.7052	Fluid Cover, M10 x 1.5, 35 mm	16
	819.7053	Fluid Cover, M10 x 1.5, 90 mm	8
	819.7052	Outlet Manifold, M10 x 1.5, 35 mm	4
	819.7052	Inlet Manifold, M10 x 1.5, 35 mm	4
		Conductive Poly, Poly, and PVDF fluid section	
	819.4491	Fluid cover, M10 x 1.5, 60 mm	16
	819.9753	Fluid cover, M10 x 1.5, 110 mm	8
	819.4375	Outlet Manifold, M8 x 1.25, 70 mm	8
	819.4377	Inlet Manifold, M8 x 1.25, 40 mm	8
		Stainless Steel and Ductile Iron fluid section	
	819.4343	Fluid cover, M10 x 1.5, 35 mm	16
	819.4307	Fluid cover, M10 x 1.5, 110 mm	8
	819.4343	Outlet Manifold, M10 x 1.5, 35 mm	4
	819.4343	Inlet Manifold, M10 x 1.5, 35 mm	4
5a	819.9759	WASHER. inlet manifold	4
5b	819.9758	WASHER. outlet manifold	4
6	-----	SEAT; <i>See page 34.</i>	4
7	-----	BALLS, <i>See page 34.</i>	4

Ref.	Part/Kit	Description	Qty.
8	-----	O-RING, manifold, (not used on some models); PTFE, <i>See page 31.</i> Used with the following seats: Geolast seats Polypropylene seats PVDF seats Santoprene seats 316 SST seats	4
9		PLATE, fluid side;	2
	819.0336	Aluminum, Ductile Iron	
	819.4311	Stainless Steel fluid section	
	819.1282	Conductive Poly, Poly (includes Ref 13a, 13b)	
	819.1288	PVDF (includes Ref 13a, 13b)	
10	819.1283	PLATE, air side	2
11		DIAPHRAGM, kit; <i>See page 35.</i>	1 kit
12	-----	DIAPHRAGM, backup, <i>included with Ref. 11 where needed</i>	2
13	819.1281	BOLT, shaft; kit; <i>includes Ref. 34, qty 2</i>	1
13a	-----	PLUG, <i>included in 9, where needed</i>	2
13b	-----	O-RING, <i>included in 9, where needed</i>	2
15		BRACKET, gear box, for models without compressor; includes refs 17 and 18 for aluminum or ductile iron fluid section	1
	819.1260	stainless steel fluid section	
	819.1262	for conductive poly, poly, or PVDF fluid section	
	819.1261		
16		COMPRESSOR, assembly; <i>includes Ref. 16a</i>	1
	819.1269	120 Volt	
	819.1270	240 Volt	
16a		COMPRESSOR	1
	859.0504	120 Volt	
	859.0505	240 Volt	
17	-----	BOLT, hex washer head, M8-1.25 x 32 mm; <i>included with Ref. 15</i>	4
18	-----	NUT; <i>included with Ref. 15 or 16</i>	4

Parts

Ref.	Part/Kit	Description	Qty.
21▲	819.4313	LABEL, warning	1
31▲	859.0353	LABEL, warning, multilingual	1
34	— — —	O-RING, for diaphragm shaft bolt; <i>included with Ref. 13</i>	2
35		BRACKET, riser; <i>used for models with a compressor; includes Ref 35a</i>	1
	819.1265	for aluminum or ductile iron fluid section	
	819.1266	for stainless steel fluid section	
	819.1267	for conductive poly, poly, or PVDF fluid section	

Ref.	Part/Kit	Description	Qty.
35a	— — —	BOLT, M8 x 1.25, 20mm	10
42	819.7014	NUT; <i>for manifold bolts on models with stainless steel fluid section</i>	8

— — — *Not sold separately.*

▲ Replacement Warning labels, signs, tags, and cards are available at no cost.

Center Section

Sample Configuration Number **VA-E50 AA HY AC HY TB AC5K5**

Pump	Fluid Section Material	Drive Section Material	Check Valve Seats	Check Valve Balls	Diaphragm	Connections	Options
VA-E50	A	A	HY	AC	HY	TB	AC5K5

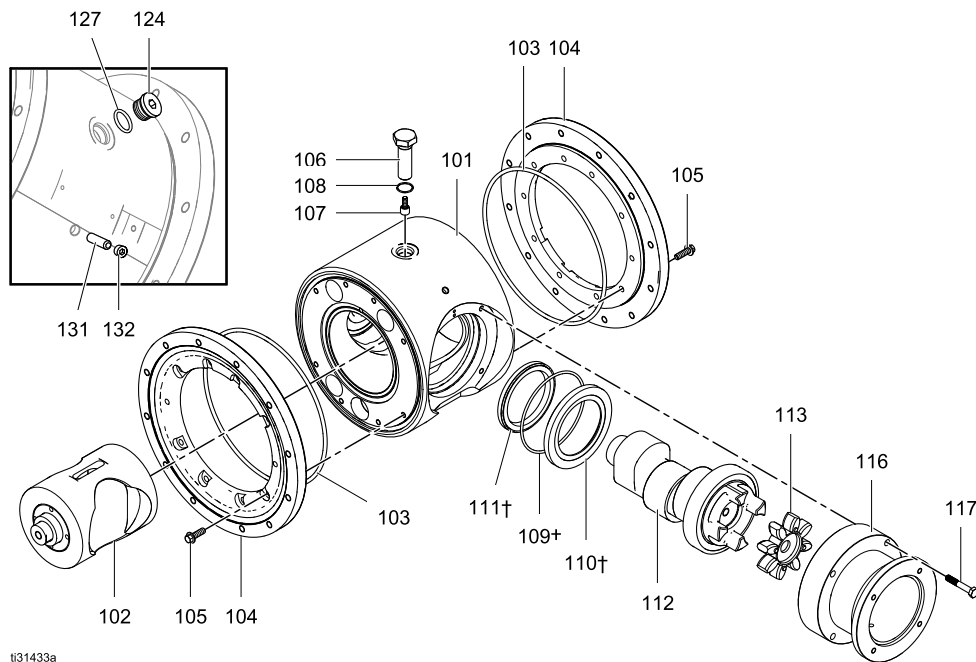

131433a

Parts

Ref	Part	Description	Qty
101	819.1253 819.1254	HOUSING, center, assembly; <i>includes plugs Aluminum (Axx) Stainless Steel (Sxx); also includes o-ring</i>	1
102	819.1237	PISTON, assembly	1
103	— — —	O-RING, air cover; <i>included with ref 104</i>	2
104	819.1278 819.1279	AIR COVER Aluminum center section <i>includes refs 103, 105</i> SST center section <i>includes refs 103, 105</i>	2
105	— — —	BOLT, air cover <i>included with ref 104</i>	16
106	819.1257	BOLT, bearing; <i>includes Refs. 107 and 108</i> for aluminum center housing	1
107	— — —	BEARING, cam follower. <i>included with Ref. 106</i>	1
108	— — —	O-RING, Size 019, Fluoroelastomer; <i>included with Ref. 106</i>	1
109†	— — —	O-RING, Size 153, Buna-N	1
110†	— — —	CARTRIDGE, seal	1
111†	— — —	SEAL, radial	1
112	819.1252	SHAFT, drive, assembly; <i>includes o-ring (Ref. 109), cartridge (Ref. 110) and seal (Ref. 111)</i>	1
113	819.1251	COUPLER, shaft	1
114	819.1250	COUPLER, gearbox; <i>includes mounting hardware</i>	1
116	819.1255 819.1256	HOUSING, alignment, assembly; <i>includes screws (Refs. 117, 120)</i> Aluminum (Axx) Stainless steel (Sxx)	1
117	— — —	SCREW, socket head, M8 x 50 mm; <i>included with Ref. 116</i>	4

Ref	Part	Description	Qty
118	819.1326 819.1325 819.1324 819.1247 819.1248 819.1249	GEARBOX; <i>includes Ref 118a, 118b, 122</i> low speed, ATEX medium speed, ATEX high speed, ATEX low speed, flameproof medium speed, flameproof high speed, flameproof	1
118a	— — —	COUPLER; <i>included with Ref 118</i>	1
118b	— — —	KEY; <i>included with Ref 118</i>	1
120	— — —	SCREW, cap, hex head, M8 x 20 mm	4
121	819.1238 819.1239 819.1240 819.1243 819.1242 819.1241 819.1246 819.1245 819.1244	MOTOR low speed gearmotor medium speed gearmotor high speed gearmotor low speed ATEX medium speed ATEX high speed ATEX low speed flameproof medium speed flameproof high speed flameproof	1
122	— — —	SCREW, cap, 1/2–13 x 1.5 in.	4
124	859.0495	PLUG, front access <i>includes ref 127</i>	1
125	— — —	SCREW, ground, M5 x 0.8	1
127	— — —	O-RING <i>included with Ref 124</i>	1
130	— — —	ELBOW, 1/8–27 npt	1
131	— — —	PIN, stop, 5/16 x 1-1/4 in.	1
132	— — —	PLUG; 1/8-27 npt	1
135	— — —	LABEL, caution	1
136	— — —	BUSHING <i>included with Ref 137</i>	
137	819.1273	Leak sensor <i>includes Ref 136</i>	

— — — Not sold separately.

† Included in Shaft Seal Repair Kit 819.1258.

Fluid Covers and Manifolds

Sample Configuration Number **VA-E50 AA HY AC HY TB AC5K5**

Pump	Fluid Section Material	Drive Section Material	Check Valve Seats	Check Valve Balls	Diaphragm	Connections	Options
VA-E50	A	A	HY	AC	HY	TB	AC5K5

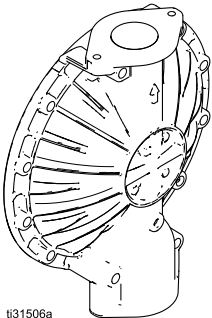
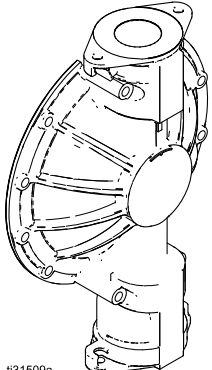
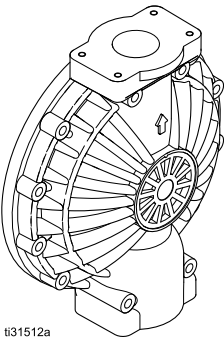
Fluid Cover Kits		
Kits include: 1 fluid cover (2)		
Aluminum, SST, Ductile Iron		
A	819.0223	 t31506a
I	819.6482	
S	819.7015	 t31509a
Conductive Polypropylene, Polypropylene, and PVDF		
C	819.0279	 t31512a
P	819.4497	
F	819.4501	

NOTE: Outlet manifolds include a Warning label. Replacement warning labels, signs, tags, and cards are available at no cost.

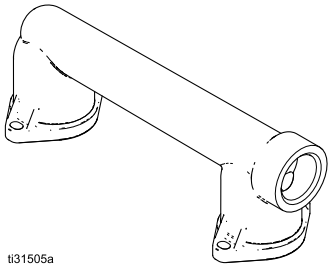
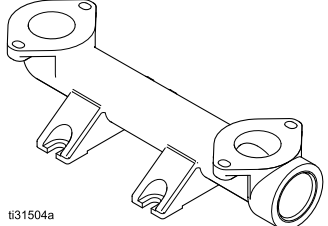
Aluminum Manifold Kits		
Kits include: 1 manifold		
Outlet (3)		
A (TN)	819.0224	 t31505a
A (TB)	819.0225	
Inlet (4)		
A (TN)	819.4299	 t31504a
A (TB)	819.6979	

Parts

Sample Configuration Number **VA-E50 AA HY AC HY TB AC5K5**

Pump	Fluid Section Material	Drive Section Material	Check Valve Seats	Check Valve Balls	Diaphragm	Connections	Options
VA-E50	A	A	HY	AC	HY	TB	AC5K5

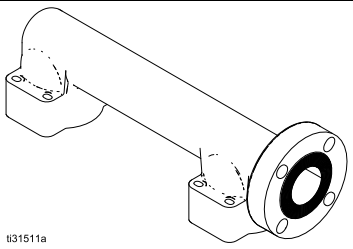
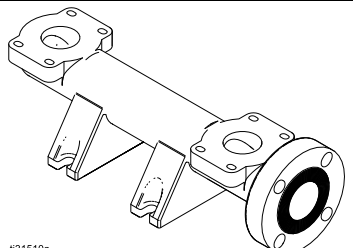
Conductive Polypropylene, Polypropylene, and PVDF Manifold Kits		
Kits include: 1 manifold)		
End Flange Outlet (3)		
C (FE)	819.0288	 i31511a
F (FE)	819.4503	
P (FE)	819.4499	
End Flange Inlet (4)		
C (FE)	819.0278	 i31510a
F (FE)	819.4502	
P (FE)	819.4498	

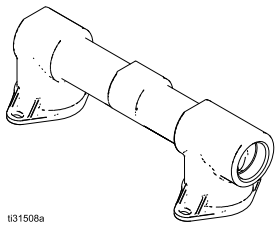
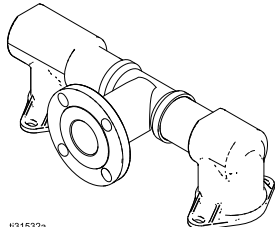
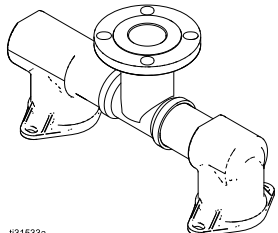
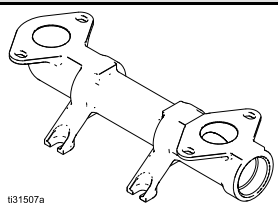
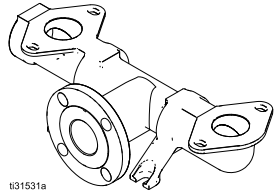
Ductile Iron and Stainless Steel		
Kits include: 1 manifold)		
Outlet (3)		
I (TB)	819.6483	 i31508a
I (TN)	819.7101	
S (TN)	819.7099	
S (TB)	819.7013	
S (FC-H)		 i31532a
S (FC-V)		 i31533a
Inlet (4)		
I (TB)	819.6345	 i31507a
I (TN)	819.7100	
S (TN)	819.7098	
S (TB)	819.7012	
S (FC-H), S (FC-V)		 i31531a

Seats and Check Balls

Sample Configuration Number **VA-E50 AA HY AC HY TB AC5K5**

Pump	Fluid Section Material	Drive Section Material	Check Valve Seats	Check Valve Balls	Diaphragm	Connections	Options
VA-E50	A	A	HY	AC	HY	TB	AC5K5

Seat Kits	
GE	819.1290
PP	819.1291
KY	819.1292
SP	819.1293
SS	819.1294
HY	819.1295

Kits include:

- 4 seats, material indicated in table.

Ball Kits	
AC	819.1296
GE	819.1297
HY	819.1298
NW	819.1299
SP	819.1300
SS	819.1301
TF	819.1302

Kits include:

- 4 balls, material indicated in table.

O-Ring Kits	
GE, PP, KY, SP, SS	819.1303

Kits include:

- 4 o-rings (8), PTFE; not used on models with TPE (HY) seats.

Diaphragms

Sample Configuration Number **VA-E50 AA HY AC HY TB AC5K5**

Pump	Fluid Section Material	Drive Section Material	Check Valve Seats	Check Valve Balls	Diaphragm	Connections	Options
VA-E50	A	A	HY	AC	HY	TB	AC5K5

Bolt-Through Diaphragm Kits	
GE	819.1275
TF	819.1277
SP	819.1274
HY	819.1276

Kits include:

- 2 diaphragms (11)
- 2 diaphragms (12)
- 1 packet anaerobic adhesive

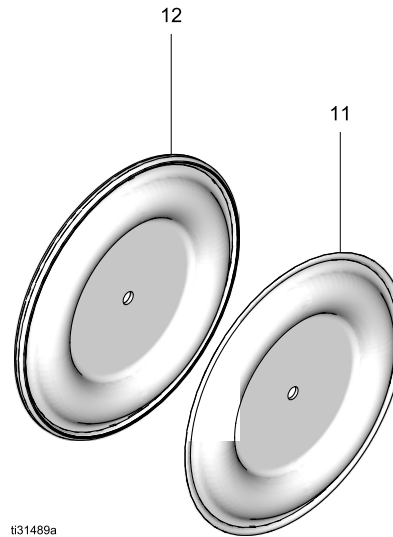

t31489a

Kits and Accessories

Center Section Repair Tool Kit 819.1272

Includes tools needed to remove the bearing from the center section.

Bearing Puller Kit 859.0529

Includes an interchangeable bearing puller set.

Seals Kit 819.1338

Includes center section seals (Ref. 103, 108, 109, 111, 127).

Technical Data

VERDERAIR VA-E50 Electric Double Diaphragm Pump		
	US	Metric
Maximum fluid working pressure	100 psi	0.7 MPa, 7 bar
Air pressure operating range	20 to 100 psi	0.14 to 0.7 MPa, 1.4 to 7 bar
Air inlet size	3/8 in. npt(f)	
Maximum suction lift (reduced if balls don't seat well due to damaged balls or seats, lightweight balls, or extreme speed of cycling)	Wet or Dry: 18 ft	Wet or Dry: 5.5 m
Maximum size pumpable solids	1/4 in.	6.3 mm
Minimum ambient air temperature for operation and storage. NOTE: Exposure to extreme low temperatures may result in damage to plastic parts.	32° F	0° C
Fluid displacement per cycle	0.6 gallons	2.27 liters
Maximum free-flow delivery	100 gpm	378 lpm
Maximum pump speed	160 cpm	
Fluid Inlet and Outlet Size		
Polypropylene, Conductive Polypropylene, PVDF, or SST Flange	DIN PN16 050-2 in ANSI 150 2 NPS JIS 10K 50	
Aluminum, Stainless Steel, Cast Iron	2 in npt(f) or 2 in bspt	
Electric Motor		
AC, Standard CE (AC5K5 , A15K5 , A25K5)		
Power	7.5 HP	5.5 kW
Number of Motor Poles	4-Pole	
Speed	1800 rpm (60 Hz) or 1500 rpm (50 Hz)	
Constant Torque	6:1	
Gear Ratio	11.25	
Voltage	3-phase 230V / 3-Phase 460V	
Maximum Amperage Load	19.5 A (230V) / 9.75 A (460V)	
IE Rating	IE3	
AC, Standard CE (BC4K0 , B14K0 , B24K0)		
Power	5.0 HP	3.7 kW
Number of Motor Poles	4-Pole	
Speed	1800 rpm (60 Hz) or 1500 rpm (50 Hz)	
Constant Torque	6:1	
Gear Ratio	16.46	
Voltage	3-phase 230V / 3-Phase 460V	
Maximum Amperage Load	13.0 A (230V) / 6.5 A (460V)	
AC, Standard CE (CC2K2 , C12K2 , C22K2)		
Power	3.0 HP	2.2 kW
Number of Motor Poles	4-Pole	
Speed	1800 rpm (60 Hz) or 1500 rpm (50 Hz)	

Constant Torque	6:1	
Gear Ratio	26.77	
Voltage	3-phase 230V / 3-Phase 460V	
Maximum Amperage Load	7.68 A (230V) / 3.84 A (460V)	
IE Rating	IE3	
AC, ATEX (AX5K5)		
Power	7.5 HP	5.5 kW
Number of Motor Poles	4-Pole	
Speed	1800 rpm (60 Hz) or 1500 rpm (50 Hz)	
Constant Torque	6:1	
Gear Ratio	11.88	
Voltage	3-phase 240V / 3-Phase 415V	
Maximum Amperage Load	20 A (230V) / 11.5 A (460V)	
AC, ATEX (BX4K0)		
Power	5.0 HP	4.0 kW
Number of Motor Poles	4-Pole	
Speed	1800 rpm (60 Hz) or 1500 rpm (50 Hz)	
Constant Torque	6:1	
Gear Ratio	16.46	
Voltage	3-phase 240V / 3-Phase 415V	
Maximum Amperage Load	14.7 A (230V) / 8.5 A (460V)	
AC, ATEX (CX2K2)		
Power	3.0 HP	2.2 kW
Number of Motor Poles	4-Pole	
Speed	1800 rpm (60 Hz) or 1500 rpm (50 Hz)	
Constant Torque	6:1	
Gear Ratio	26.77	
Voltage	3-phase 240V / 3-Phase 415V	
Maximum Amperage Load	8.5 A (230V) / 5.0 A (460V)	
AC, Flameproof (AF5K5)		
Power	7.5 HP	5.5 kW
Number of Motor Poles	4-Pole	
Speed	1800 rpm (60 Hz) or 1500 rpm (50 Hz)	
Constant Torque	6:1	
Gear Ratio	11.88	
Voltage	3-phase 230V / 3-Phase 460V	
Maximum Amperage Load	20.0 A (230V) / 10.0 A (460V)	
AC, Flameproof (BF4K0)		
Power	5.0 HP	3.7 kW
Number of Motor Poles	4-Pole	
Speed	1800 rpm (60 Hz) or 1500 rpm (50 Hz)	
Constant Torque	6:1	
Gear Ratio	16.46	

Technical Data

Voltage	3-phase 230V / 3-Phase 460V	
Maximum Amperage Load	13.0 A (230V) / 6.5 A (460V)	
AC, Flameproof (CF2K2)		
Power	3.0 HP	2.2 kW
Number of Motor Poles	4-Pole	
Speed	1800 rpm (60 Hz) or 1500 rpm (50 Hz)	
Constant Torque	6:1	
Gear Ratio	26.77	
Voltage	3-phase 230V / 3-Phase 460V	
Maximum Amperage Load	8 A (230V) / 4 A (460V)	
Leak Sensor		
Contact Ratings:		
State	Normally closed	
Voltage	240V Max (AC/DC)	
Current	0.28 A max at 120 VAC 0.14 A max at 240 VAC 0.28 A max at 24 VDC 0.07 A max at 120 VDC	
Power	30 W max	
Ambient Temperature	-20° to 40°C (-4° to 104°F)	
Ex Ratings:		
Classification: "simple apparatus" in accordance with UL/EN/IEC 60079-11, clause 5.7		
Class I, Group D, Class II, Group F&G, Temp Code T3B		
		
II 2 G Ex ib IIC T3		
Parameters	$U_i = 24 \text{ V}$ $I_i = 280 \text{ mA}$ $P_i = 1.3 \text{ W}$ $C_i = 2.4 \text{ pF}$ $L_i = 1.00 \text{ } \mu\text{H}$	
Noise Data		
Sound Power (measured per ISO-9614-2)		
at 90 psi fluid pressure and 80 cpm	84 dBa	
at 60 psi fluid pressure and 160 cpm (full flow)	92 dBa	
Sound Pressure [tested 3.28 ft (1 m) from equipment]		
at 90 psi fluid pressure and 80 cpm	74 dBa	
at 60 psi fluid pressure and 160 cpm (full flow)	82 dBa	
Wetted Parts		
Wetted parts include material(s) chosen for seat, ball, and diaphragm options, plus the pump's material of construction: Aluminum, Polypropylene, Stainless Steel, Conductive Polypropylene, or PVDF		
Non-wetted parts		
Non-wetted parts include aluminum, coated carbon steel, PTFE, stainless steel, polypropylene		

Weights

Pump Material		Motor/Gearbox																			
Fluid Section	Center Section	Standard AC ([^] = 1, 2, or C) (For [^] = 1 or 2, add 28 lb (13 kg) to weight)						ATEX AC						Flameproof AC						No Gear- motor	
		A [^] 5K5		B [^] 4K0		C [^] 2K2		AX5K5		BX4K0		CX2K2		AF5K5		BF4K0		CF2K2		WG	
		lb	kg	lb	kg	lb	kg	lb	kg	lb	kg	lb	kg	lb	kg	lb	kg	lb	kg	lb	kg
Aluminum	Aluminum	280	127	248	112	228	103	396	179	271	123	246	111	437	198	348	158	339	154	138	62
Ductile Iron	Aluminum	329	149	297	135	277	126	445	202	320	145	295	134	486	220	397	180	388	176	187	85
Conductive Polypropylene	Aluminum	275	125	243	110	223	101	391	177	266	121	241	109	432	196	343	155	334	151	133	60
Conductive Polypropylene	Stainless Steel	357	162	325	147	305	138	473	214	348	158	323	146	514	233	425	193	416	188	215	97
Polypropylene	Aluminum	271	123	239	108	219	99	387	175	262	119	237	107	428	194	339	154	330	149	129	58
Polypropylene	Stainless Steel	353	160	321	146	301	137	469	213	344	156	319	144	510	231	421	191	412	187	211	95
PVDF	Aluminum	290	132	258	117	238	108	406	184	281	127	256	116	447	203	358	162	349	158	148	67
PVDF	Stainless Steel	372	169	340	154	320	145	488	221	363	165	338	153	529	240	440	199	431	195	230	104
Stainless Steel	Aluminum	342	155	310	141	290	132	458	208	333	151	308	139	499	226	410	186	401	182	200	90
Stainless Steel	Stainless Steel	424	192	392	178	372	169	540	245	415	188	390	177	581	264	492	223	483	219	282	128

Technical Data

Component/Model	U.S.	Metric
Compressor	28 lb	13 kg

VFD			
Model	Hp / kW	Input Voltage Range	Nominal Output Voltage
819.1305	3.0 / 2.2	170–264 VAC	208–240 VAC, 3 phase
819.1306	3.0 / 2.2	340–528 VAC	400–480 VAC, 3 phase
819.1284	5.0 / 4.0	170–264 VAC	208–240 VAC, 3 phase
819.1285	5.0 / 4.0	340–528 VAC	400–480 VAC, 3 phase
819.1286	7.5 / 5.5	170–264 VAC	208–240 VAC, 3 phase
819.1287	7.0 / 5.5	340–528 VAC	400–480 VAC, 3 phase

Fluid Temperature Range

NOTICE
Temperature limits are based on mechanical stress only. Certain chemicals will further limit the fluid temperature range. Stay within the temperature range of the most-restricted wetted component. Operating at a fluid temperature that is too high or too low for the components of your pump may cause equipment damage.

Diaphragm/Ball/Seat Material	Fluid Temperature Range					
	Aluminum Cast Iron, or Stainless Steel Pumps		Polypropylene or Conductive Polypropylene Pumps		PVDF Pumps	
	Fahrenheit	Celsius	Fahrenheit	Celsius	Fahrenheit	Celsius
Acetal (AC)	10° to 180°F	-12° to 82°C	32° to 150°F	0° to 66°C	10° to 180°F	-12° to 82°C
Geolast® (GE)	-40° to 150°F	-40° to 66°C	32° to 150°F	0° to 66°C	10° to 150°F	-12° to 66°C
Polychloroprene (TF diaphragm or NW balls)	0° to 180°F	-18° to 82°C	32° to 150°F	0° to 66°C	10° to 180°F	-12° to 82°C
Polypropylene (PP)	32° to 150°F	0° to 66°C	32° to 150°F	0° to 66°C	32° to 150°F	0° to 66°C
PTFE check balls or two-piece PTFE/EPDM diaphragm (TF)	40° to 220°F	4° to 104°C	40° to 150°F	4° to 66°C	40° to 220°F	4° to 104°C
PVDF (KY)	10° to 225°F	-12° to 107°C	32° to 150°F	0° to 66°C	10° to 225°F	-12° to 107°C
Santoprene® (SP)	-40° to 180°F	-40° to 82°C	32° to 150°F	0° to 66°C	10° to 225°F	-12° to 107°C
TPE (HY)	-20° to 150°F	-29° to 66°C	32° to 150°F	0° to 66°C	10° to 150°F	-12° to 66°C

* The maximum temperature listed is based on the ATEX standard for T4 temperature classification.

Customer Services/Guarantee

CUSTOMER SERVICES

If you require spare parts, please contact your local distributor, providing the following details:

- Pump Model
- Type
- Serial Number, and
- Date of First Order.

GUARANTEE

All VERDER pumps are warranted to the original user against defects in workmanship or materials under normal use (rental use excluded) for two years after purchase date. This warranty does not cover failure of parts or components due to normal wear, damage or failure which in the judgement of VERDER arises from misuse.

Parts determined by VERDER to be defective in material or workmanship will be repaired or replaced.

LIMITATION OF LIABILITY

To the extent allowable under applicable law, VERDER's liability for consequential damages is expressly disclaimed. VERDER's liability in all events is limited and shall not exceed the purchase price.

WARRANTY DISCLAIMER

VERDER has made an effort to illustrate and describe the products in the enclosed brochure accurately; however, such illustrations and descriptions are for the sole purpose of identification and do not express or imply a warranty that the products are merchantable, or fit for a particular purpose, or that the products will necessarily conform to the illustration or descriptions.

PRODUCT SUITABILITY

Many regions, states and localities have codes and regulations governing the sale, construction, installation and/or use of products for certain purposes, which may vary from those in neighboring areas. While VERDER attempts to assure that its products comply with such codes, it cannot guarantee compliance, and cannot be responsible for how the product is installed or used. Before purchasing and using a product, please review the product application as well as the national and local codes and regulations, and be sure that product, installation, and use complies with them.

Original instructions. This manual contains English.

Revision D, January 2020

Austria

Verder Austria
Eitnergasse 21/Top 8
A-1230 Wien
AUSTRIA
Tel: +43 1 86 51 074 0
Fax: +43 1 86 51 076
e-mail: office@verder.at

Belgium

Verder nv
Kontichsesteenweg 17
B-2630 Aartselaar
BELGIUM
Tel: +32 3 877 11 12
Fax: +32 3 877 05 75
e-mail: info@verder.be

China

Verder Shanghai Instruments and Equipment Co., Ltd
Building 8 Fuhai Business Park No. 299
Bisheng Road, Zhangjiang Hiteck Park
Shanghai 201204
CHINA
Tel: +86 21 33932950
Fax: +86 21 33932955
e-mail: info@verder.cn

Bulgaria

Verder Bulgaria Ltd
Vitosh department,
Manastriski Livadi Zapad
district,
110 Bulgaria Blvd., 2-nd
Floor, apt. 15-16,
1618 - Sofia
BULGARIA
Tel: 0878407370
Fax: 02 9584085
email: office@verder.bg

Czech Republic

Verder s.r.o.
Vodnanská 651/6 (vchod
Chlumecka 15)
198 00 Praha 9-Kyje
CZECH REPUBLIC
Tel: +420 261 225 386-7
Web: <http://www.verder.cz>
e-mail: info@verder.cz

France

Verder France
8 Allée Rosa Luxembourg
Immeulde Arizona
95610 Eragny sur Oise
FRANCE
Tel: +33 173 43 98 41
Fax: +33 134 64 44 50
e-mail: info@verder.fr

Germany

Verder Deutschland GmbH
Retsch-Allee 1-5
42781 Haan
GERMANY
Tel: 02104/2333-200
Fax: 02104/2333-299
e-mail: info@verder.de

Hungary

Verder Hungary Kft
Budafoke ut 187 - 189
HU-1117 Budapest
HUNGARY
Tel: 0036 1 3651140
Fax: 0036 1 3725232
e-mail: info@verder.hu

India

Verder India Pumps Pvt
Ltd.
Plot No-3B, D-1 Block,
MIDC Chinchwad,
Pune - 411019
INDIA
e-mail:
Sales@verder.co.in
www.verder.co.in

Italy

Verder Italia
Via Maestri Del lavoro, 5
02100 Vazia, Rieti
ITALY
Tel: +39 07 46 229064
e-mail: info@verder.it

The Netherlands

Verder BV
Leningradweg 5
NL 9723 TP Groningen
THE NETHERLANDS
Tel: +31 50 549 59 00
Fax: +31 50 549 59 01
e-mail: info@verder.nl

Poland

Verder Polska
ul.Porcelanowa 23
PL-40 036 Katowice
POLAND
Tel: +48 32 78 15 032
Fax: +48 32 78 15 034
e-mail: verder@verder.pl

Romania

Verder România
Drumul Balta Doamnei
no 57-61
Sector 3
CP 72-117
032624 Bucuresti
ROMANIA
Tel: +40 21 335 45 92
Fax: +40 21 337 33 92
e-mail: office@verder.ro

Slovak Republik

Verder Slovakia s.r.o.
Silacska 1
SK-831 02 Bratislava
SLOVAK REPUBLIK
Tel: +421 2 4463 07 88
Fax: +421 2 4445 65 78
e-mail: info@verder.sk

South Africa

Verder SA
197 Flaming Rock Avenue
Northlands Business Park
Newmarket Street
ZA Northriding
SOUTH AFRICA
Tel: +27 11 704 7500
Fax: +27 11 704 7515
e-mail: info@verder.co.za

Switzerland

Verder Deutschland GmbH
Sales Switzerland
Retsch-Allee 1-5
D-42781 Haan
GERMANY
Tel: +41 (0)61 331 33 13
Fax: +41 (0)61 331 63 22
e-mail: info@verder.ch

United Kingdom

Verder UK Ltd.
Unit 3 California Drive
Castleford, WF10 5QH
UNITED KINGDOM
Tel: +44 (0) 1924 221 001
Fax: +44 (0) 1132 465 649
e-mail: info@verder.co.uk

United States of America

Verder Inc.
312 Corporate Parkway
Suite 101
Macon, GA 31210
USA
Tel: +1 877 783 7337
Fax: +1 478 476 9867
e-mail: sales@verder-us.com