

G10 Series

Maximum Flow Rate: 33.4 l/min (8.8 gpm)
Maximum Pressure: 103 bar (1500 psi) for Metallic Pump Heads
24 bar (350 psi) for Non-metallic Pump Heads

API 674



WANNER
Hydra-Cell[®]
Seal-less Pump Technology

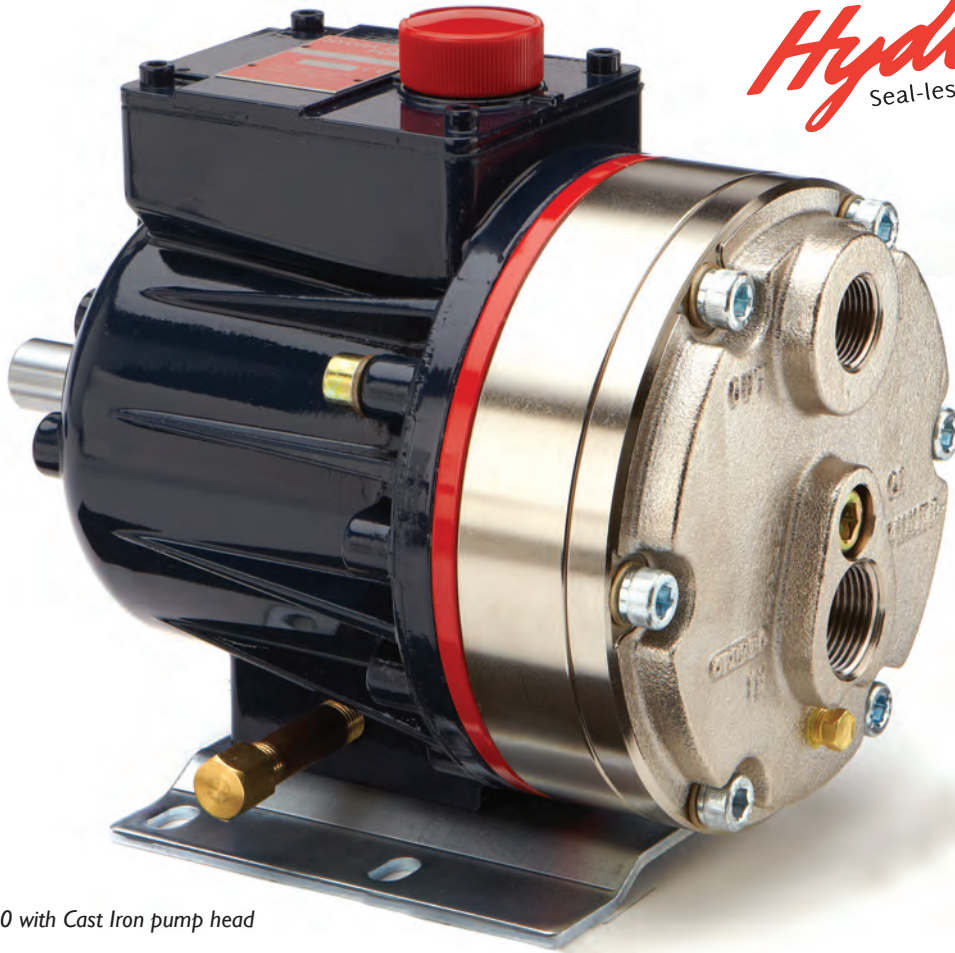

G10 with Cast Iron pump head



G10 with Stainless Steel pump head and Tri-clamp flanges



G10 with Polypropylene pump head



G10 with Stainless Steel pump head and ANSI RF flanges

G10 Series Performance

Capacities

Flow

Model	Max. Input rpm	Max. Flow	
		@ 69 bar (1000 psi) gpm	l/min
G10-X	1450	8.1	30.6
G10-E	1750	8.8	33.4
G10-S	1750	6.0	22.7
G10-I	1750	4.0	15.0
@ 103 bar (1500 psi)			
G10-X	790	4.26	15.1
G10-E	790	3.87	14.7

Performance and specification ratings apply to G10 configurations unless specifically noted otherwise.

Pressure

Maximum Inlet Pressure
17 bar (250 psi)

Maximum Discharge Pressure

Metallic Pump Heads:

G10-X, E, S, I to 69 bar (1000 psi)

G10-X to 103 bar (1500 psi) @ 790 rpm max.

Non-metallic Pump Heads:

17 bar (250 psi) Polypropylene

24 bar (350 psi) PVDF

Maximum Flow at Designated Pressure

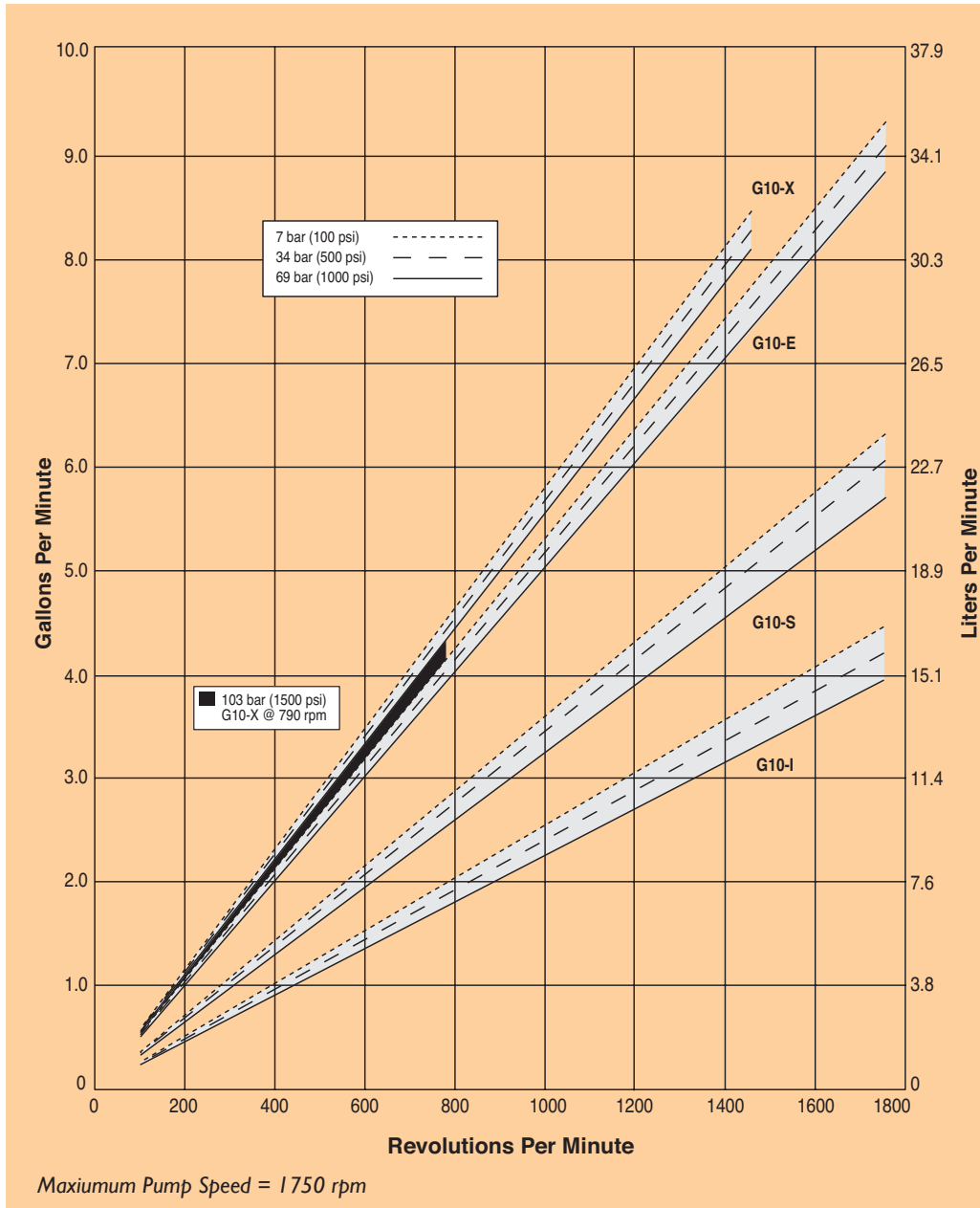

G10 Series Specifications

Flow Capacities @ 69 bar (1000 psi) 4-pole Motor @ 50 Hz

Model	rpm	gpm	l/min
G10-X	1450	8.10	30.6
G10-E	1450	6.63	25.1
G10-S	1450	4.96	18.8
G10-I	1450	3.30	12.5

Flow Capacities @ 69 bar (1000 psi) 6-pole Motor @ 50 Hz

Model	rpm	gpm	l/min
G10-X	960	5.19	19.6
G10-E	960	4.39	16.6
G10-S	960	3.28	12.4
G10-I	960	2.19	8.3

Delivery @ 103 bar (1500 psi)

Model	gal/rev	liters/rev
G10-X	0.0054	0.0205
G10-E	0.0049	0.0186

Delivery @ 69 bar (1000 psi)

Model	gal/rev	liters/rev
G10-X	0.0056	0.0211
G10-E	0.0051	0.0191
G10-S	0.0034	0.0130
G10-I	0.0023	0.0086

Maximum Discharge Pressure

Metallic Heads:	69 bar (1000 psi) @1450 rpm (G10-X)
	69 bar (1000 psi) @1750 rpm (G10-E, S, I)
	103 bar (1500 psi) @790 rpm (G10-X)
Non-metallic Heads:	17 bar (250 psi) Polypropylene
	24 bar (350 psi) PVDF

Maximum Inlet Pressure 17 bar (250 psi)

Maximum Operating Temperature

Metallic Heads:	121 °C (250 °F) - Consult factory for correct component selection for temperatures from 71 °C (160 °F) to 121 °C (250 °F).
Non-metallic Heads:	60 °C (140 °F)

Maximum Solids Size 500 microns

Inlet Port	1 inch BSPT
	1 inch NPT
	150lb ANSI RF
	1-1/2 inch Tri-clamp

Discharge Port	3/4 inch BSPT
	3/4 inch NPT
	600lb ANSI RF
	1 inch Tri-clamp

Shaft Diameter 22.2 mm (7/8 inch)

Shaft Rotation Reverse (bi-directional)

Bearings Tapered roller bearings

Oil Capacity 1.05 liters (1.1 US quarts)

Weight

Metallic Heads:	21.8 kg (48 lbs.)
Non-metallic Heads:	15.9 kg (35 lbs.)

Calculating Required Power

$$\frac{15 \times \text{rpm}}{63,000} + \frac{\text{gpm} \times \text{psi}}{1,460} = \text{electric motor hp}$$

$$\frac{15 \times \text{rpm}}{84,428} + \frac{\text{l/min} \times \text{bar}}{511} = \text{electric motor kW}$$

Calculating Pulley Size

$$\frac{\text{motor pulley OD}}{\text{pump rpm}} = \frac{\text{pump pulley OD}}{\text{motor rpm}}$$

When using a variable frequency controller (VFD) calculate the hp or kW at minimum and maximum pump speed to ensure the correct hp or kW motor is selected. Note that motor manufacturers typically de-rate the service factor to 1.0 when operating with a VFD.

Net Positive Suction Head (NPSHr)

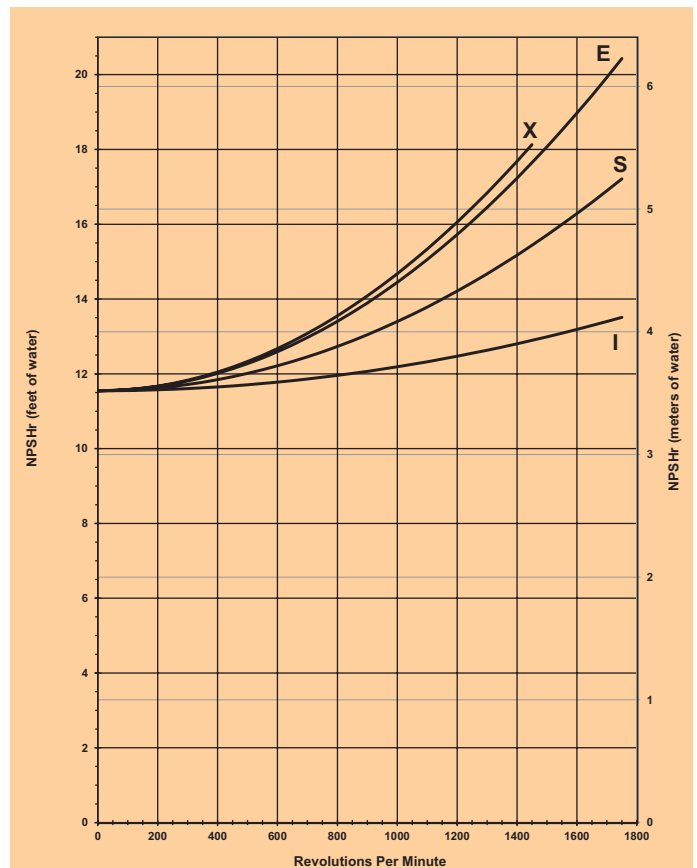

Positive inlet pressure required for:

- A) All pumps with PTFE diaphragms
- B) Pumps with I-cam (consult factory)

Self-priming:

Each Hydra-Cell pump has different lift capability depending on model size, cam angle, speed, and fluid characteristics. To ensure that your specific lift characteristics are met, refer to the inlet calculations regarding friction, and acceleration head losses in your Hydra-Cell Installation & Service Manual. Compare those calculations to the NPSHr curves above.

G10 Series Representative Drawings

G10 Models with Tri-clamp Flanges mm (Inches)

Maximum Discharge Pressure: 80 bar

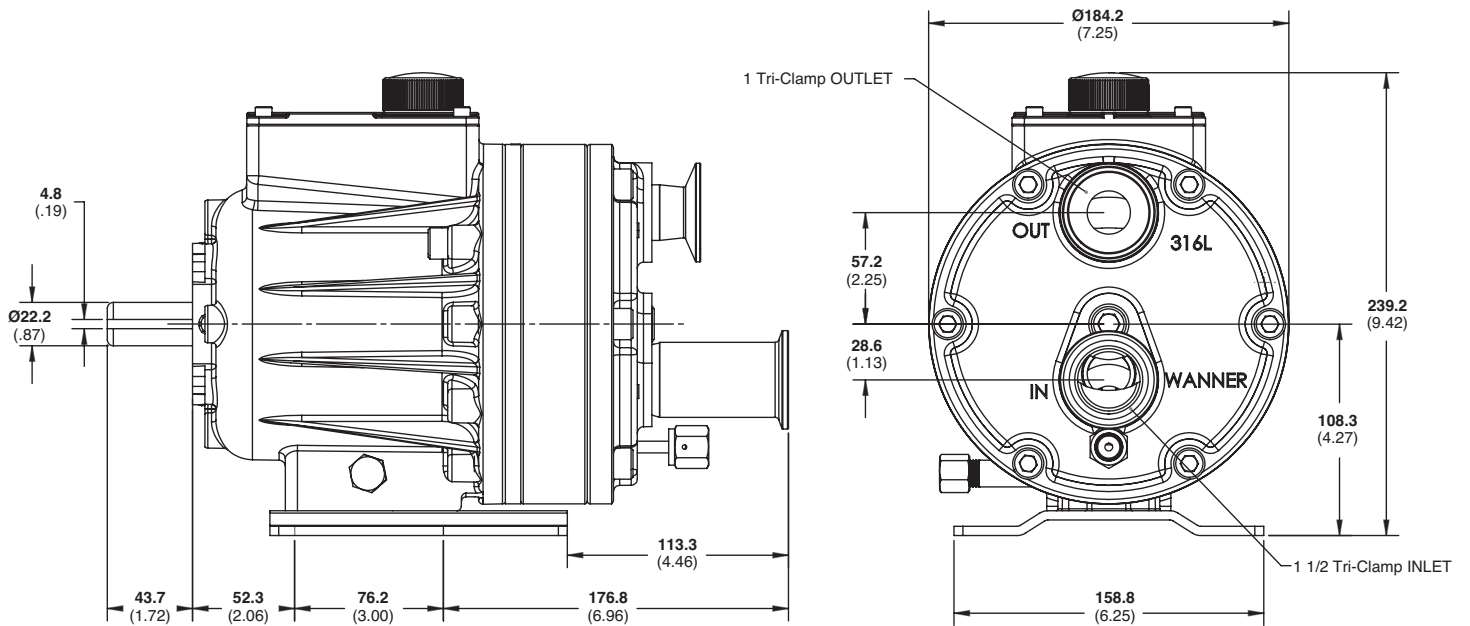

G10 Models with ANSI RF Flanges mm (Inches)

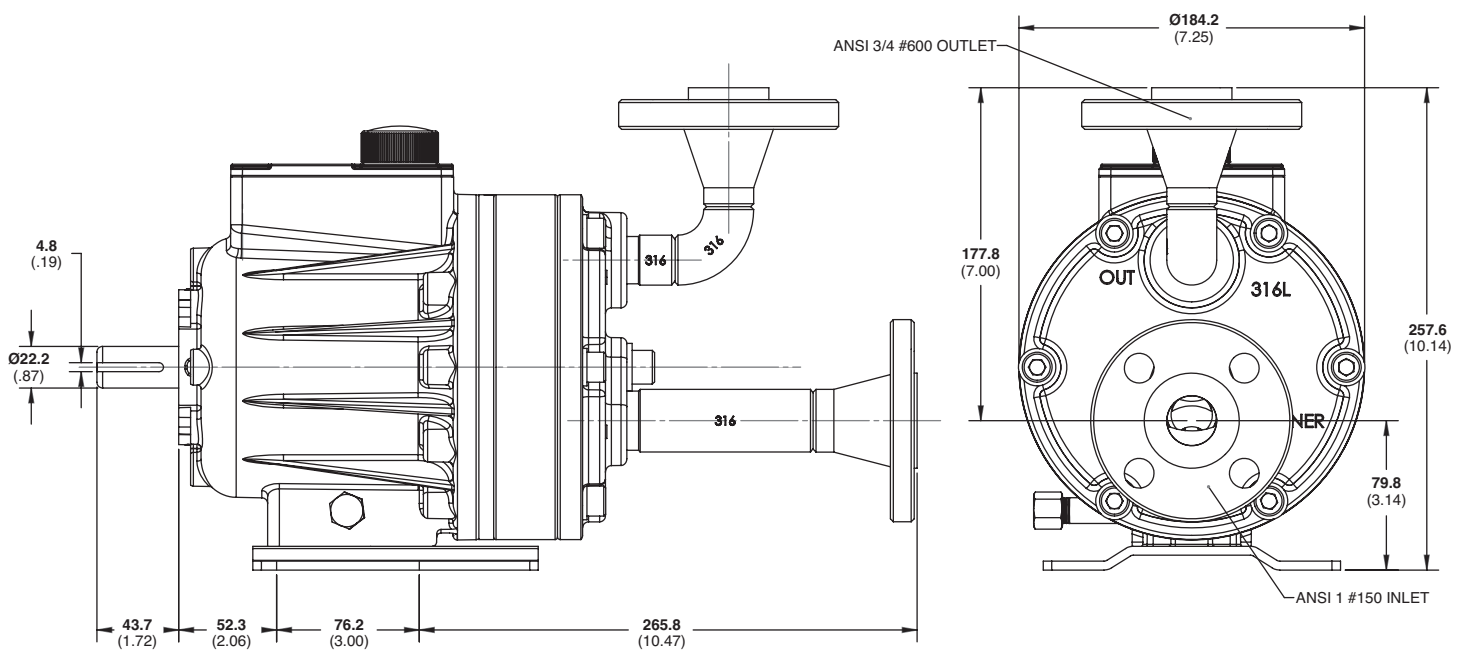

G10 Series **Adaptors/Valves/Baseplates**

Pump/Motor Adaptor mm (Inches)

Part Number: A04-003-1200

Must be ordered separately for G10 models for use with IEC 80 - 90 frame motors, B5 flange.

NEMA adaptor available - consult factory.

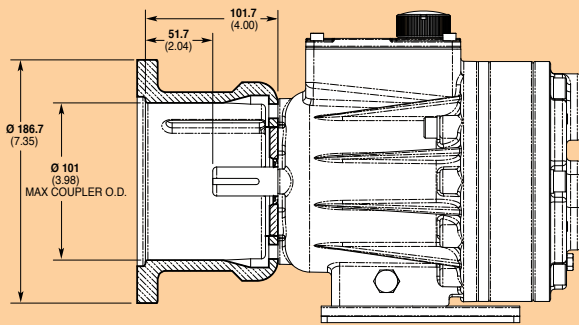

Part Number: A04-004-1200

Must be ordered separately for G10 models for use with IEC 100 - 112 frame motors, B5 flange.

NEMA adaptor available - consult factory.

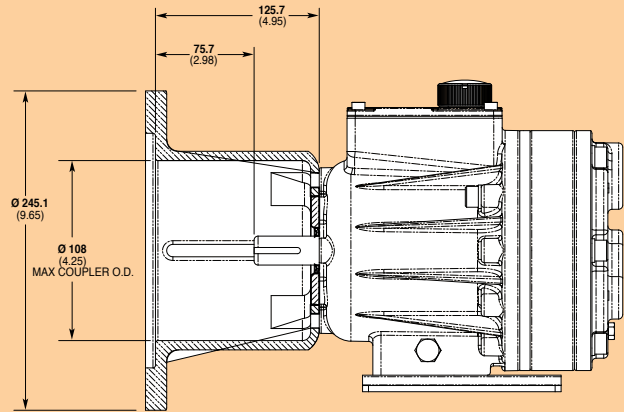

Valve Selection

A seal-less C62 Pressure Regulating Valve is recommended for Hydra-Cell G10 pumping systems, especially for high-pressure requirements or when handling dirty fluids.



A C22 Pressure Regulating Valve provides a capable, lower-cost alternative to C62 valves for Hydra-Cell G10 pumping systems.



IEC Baseplates

Complete assembly (excluding pump and motor) for IEC 90, 100 and 132 frame motors in 304 Stainless Steel.



G10 Series **How to Order**

Ordering Information



A complete G10 Series Model Number contains 12 digits including 9 customer-specified design and materials options, for example: G10XKBTHFECA.

Digit	Order Code	Description
1-3	G10	Pump Configuration Shaft-driven (BSPT Ports or ANSI Flanges)* *Pump/motor adaptors ordered separately. See previous page.
4	X E S I	Hydraulic End Cam Max 30.6 l/min (8.1 gpm) @ 1450 rpm Max 25.1 l/min (6.6 gpm) @ 1450 rpm Max 18.8 l/min (5.0 gpm) @ 1450 rpm Max 12.5 l/min (3.3 gpm) @ 1450 rpm
5	K -	Pump Head Version Kel-Cell BSPT Ports ATEX <i>(Note: ATEX 94/9/EC Certified, Category 2, Zone 1. Includes certificate and oil level monitor.)</i>
6	B C G M N P R S - - T	Pump Head Material Brass Cast Iron (Nickel-plated) Duplex Alloy 2205 (with Hastelloy C followers & follower screws) PVDF (with Hastelloy C followers & follower screws) Polypropylene (with Hastelloy C followers & follower screws) Polypropylene (with 316L Stainless Steel followers & follower screws) 316L Stainless Steel ANSI RF flange class 150lb x 600lb 316L Stainless Steel 316L Stainless Steel with Tri-clamp (1-1/2" Inlet & 1" Discharge) flanges polished to 0.8 Ra♦ <i>(Includes polishing of Pump Head, Valve Plate, Valves, Valve Seats, Springs & Retainers to 0.8 Ra, Sanitary Drain along with TSE, Passivation, Surface Finish and Weld Procedure Certificates)</i> 316L Stainless Steel with Tri-clamp (1-1/2" Inlet & 1" Discharge) flanges polished to 0.4 Ra♦ <i>(Includes polishing of Pump Head, Valve Plate, Valves, Valve Seats, Springs & Retainers to 0.4 Ra, Sanitary Drain along with TSE, Passivation, Surface Finish and Weld Procedure Certificates)</i> Hastelloy CW12MW
7	A E G J P T	Diaphragm & O-ring Material Aflas diaphragm / PTFE O-ring EPDM (requires EPDM-compatible oil - Digit 12 oil code C) FKM PTFE (available with E and S cams only; 1200 rpm max.) Neoprene Buna-N

Digit	Order Code	Description
8	C D H S T	Valve Seat Material Ceramic Tungsten Carbide 17-4 Stainless Steel 316L Stainless Steel Hastelloy C
9	C D F N T	Valve Material Ceramic Tungsten Carbide 17-4 Stainless Steel Nitronic 50 Hastelloy C
10	D E T	Valve Springs Titanium Elgiloy (Exceeds SST grade 328) Hastelloy C
11	C H M P T Y	Valve Spring Retainers Celcon 17-7 Stainless Steel PVDF Polypropylene Hastelloy C Nylon (Zytel)
12	A B C E G H	Hydra-Oil 10W30 standard-duty oil 40-wt for continuous-duty oil (use with 316L SST or Hastelloy CW12MW pump head - standard) EPDM-compatible oil Food-contact oil 5W30 cold-temp severe-duty synthetic oil 15W50 high-temp severe duty synthetic oil

♦ Selecting this option will result in a Wanner International generated Pump Code, stamped onto the pump.

G10 Pump Housing is standard as Cast Aluminum. Upgrade to Ductile Iron available.
G10 (Plastic Heads Only) available with 316 Support Faceplate Kit.



WANNER ENGINEERING - WORLD HEADQUARTERS & MANUFACTURING
Minneapolis USA
t: (612) 332-5681
e: sales@wannereng.com

WANNER PUMPS
Kowloon HONG KONG
t: +852 3428 6534
e: sales@wannerpumps.com

WANNER INTERNATIONAL
Hampshire UK
t: +44 (0) 1252 816847
e: sales@wannerint.com

WANNER ENGINEERING
Latin American Office
t: +55 (11) 4081-7098
e: sales@wannereng.com

WANNER PUMPS
Shanghai CHINA
t: +86-21-6876 3700
e: sales@wannerpumps.com